



DialDim™ Lighting Controller
BMW R1250GS
 DNL.WHS.25600



Thank you for choosing DENALI

We know you would rather be riding your bike than wrenching on it, so we go the extra mile to make sure our instructions are clear and as easy to understand as possible. If you have any questions, comments, or suggestions don't hesitate to give our experts a call at 401.360.2550 or visit WWW.DENALIELECTRONICS.COM

Please Read Before Installing

DENALI products should always be installed by a qualified motorcycle technician. If you are unsure of your ability to properly install a product, please have the product installed by your local motorcycle dealer. DENALI takes no responsibility for damages caused by improper installation. **Caution:** When installing electronics it is extremely important to pay close attention to how wires are routed, especially when mounting products to the front fender, front fork, or fairing of your motorcycle. Always be sure to turn the handlebars fully left, fully right, and fully compress the suspension to ensure the wires will not bind and have enough slack for your motorcycle to operate properly.

Installation Tips

We strongly recommend using medium strength liquid thread locker on all screws and bolts. It is also important to ensure that all hardware is tightened to the proper torque specifications as listed in your owner's manual. For included accessory hardware please refer to the default torque specifications provided below. Inspect all hardware after the first 30 miles to ensure that proper torque specifications are maintained.

Bolt Size	in-lbs	ft-lbs	Nm
M3	10.0 in-lbs	-	1.0 Nm
M4	23.0 in-lbs	-	2.5 Nm
M5	44.5 in-lbs	3.5 ft-lbs	5.0 Nm
M6	78.0 in-lbs	6.5 ft-lbs	9.0 Nm
M8	-	13.5 ft-lbs	18.0 Nm
M10	-	30.0 ft-lbs	41.0 Nm
M12	-	52.0 ft-lbs	71.0 Nm

Hardware Sizing Guide

Not sure what size bolt you have? Use this ruler to measure screws, bolts, spacers, etc. Remember, the length of a screw or bolt is measured from the start of the "mounting surface" to the end of the screw, so only include the screw head when measuring countersunk screws.

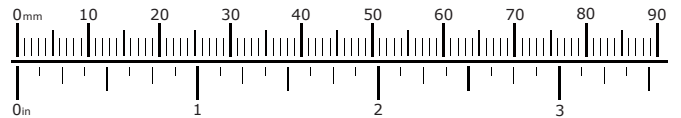

What's In The Box?



- (a) DialDim™ Controller.....Qty 1
- (b) DialDim™ Switch.....Qty 1
- (c) 7/8" Switch Mounting Band.....Qty 1

- (d) M3.5x6 DIN 912.....Qty 2
- (e) Trigger Harness.....Qty 1
- (f) Light Extension Cables.....Qty 4

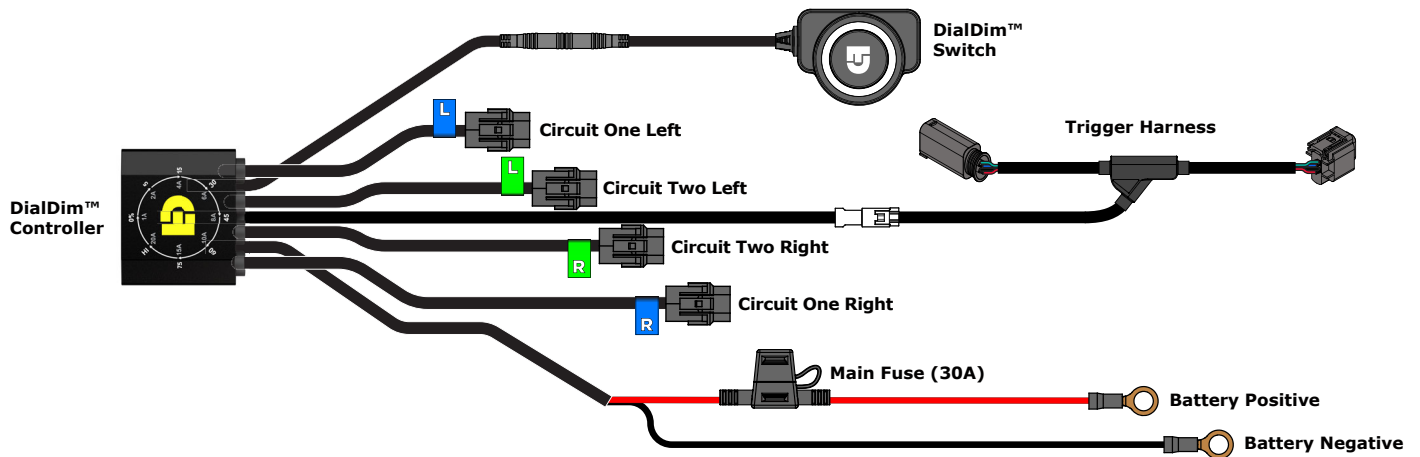

1.1 - Overview of Controller

The DENALI DialDim™ Lighting Controller features a multicolor halo dimming switch that allows you to independently turn on/off and dim two sets of auxiliary lights from a single consolidated wiring harness. The LED halo switch displays your exact settings and allows for effortless dimming on the fly. The blue halo controls light set one and the green halo controls light set two; simply double click to switch between the two circuits.

The controller also features a Trigger Harness that receives high beam, turn signal, and horn inputs. This seamlessly unlocks intelligent flash features that can cancel your auxiliary lights with your turn signal, flash your auxiliary lights as a turn signal, or strobe your lights when you sound your horn.

The dedicated light outputs are labeled and color coded so adding one or two sets of lights to your vehicle couldn't be any easier. Connect your main lights to the blue leads and your 2nd set of lights (typically fog or visibility lights) to the green leads.

In addition to the DialDim Controller and Switch, the kit includes four 60" plug-&-play light extensions and a 7/8" handlebar switch mount. Simply add the light pods and you're ready to ride!

2. Features Overview



On/Off & Dim

Independently control two sets of lights on/off and intensity level using the single DialDim™ Switch. The blue halo controls light set one and the green halo controls light set two. Double click to switch between the two circuits.



Cancel with Turn Signal

The main lights (blue circuit 1) will cancel in sync with your signal to prevent "washing out" your factory turn signal.



Electronically Fused Circuits

Both light circuits are electronically fused and can be set right from the switch itself! The halo will illuminate red to notify you when a circuit fused is tripped.



High/Low Sync

Your auxiliary lights will automatically switch between your selected dim setting to full intensity with the factory high beam switch.



Flash as Turn Signal

When enabled your amber visibility lights (green circuit 2) will flash in sync with your factory turn signals.



Voltage Display Indicator

Upon vehicle startup, the switch halo will flash green to indicate a healthy battery voltage, or flash red to indicate a battery voltage that is below 11.8v.

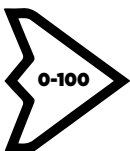

Stealth Mode

A clever 0% dim setting on the switch allows your lights to be "off" during normal driving conditions but will jump to 100% intensity with your vehicle high beam switch. The lights will also react to turn signal and horn inputs in this mode but will remain off when no inputs are detected.



Strobe with Horn

When enabled your auxiliary lights on both circuits will strobe at 4Hz when you sound your horn.



Low Voltage Cutoff

If battery voltage drops below 10.8v the lights will not power on preventing you from being stranded. The switch halo will flash 4 red LEDs to indicate the low voltage condition.

3. Installing The Harness

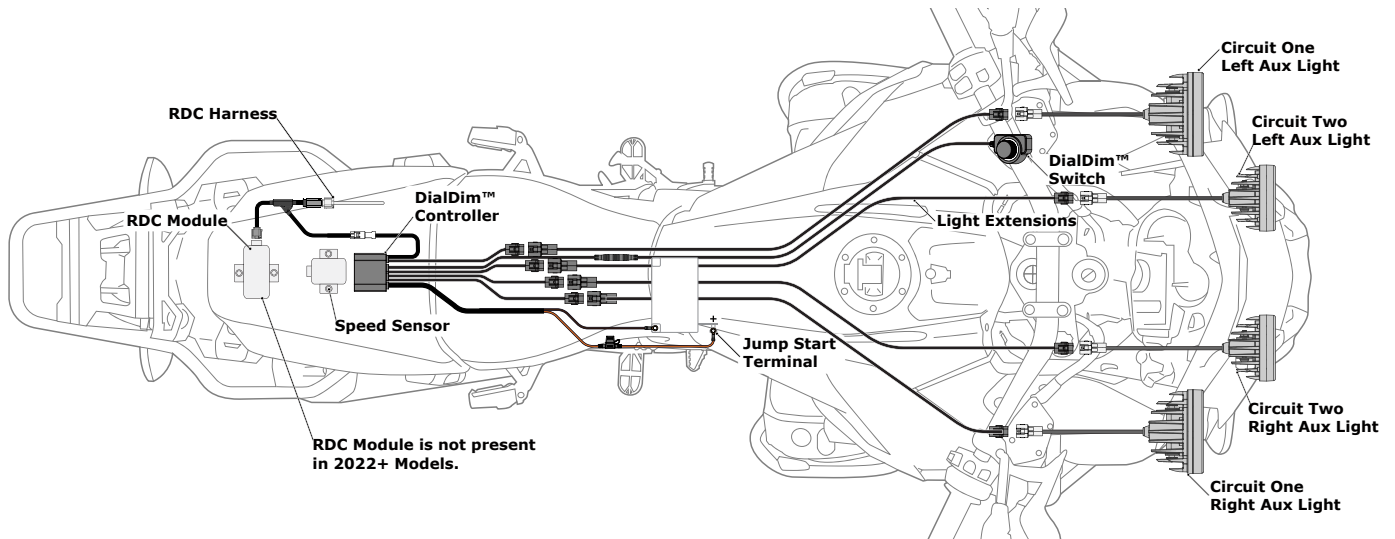

3.1 - Connecting The Trigger Harness

The DialDim Controller features an input Trigger Harness, that when connected to the vehicle it unlocks intelligent flash features and provides the Switching signal required to turn your DialDim on and off with ignition.

Step One: Remove the front and rear passenger seats.

Step Two: Remove the Luggage Rack to reveal the RDC Module.

NOTE: If there isn't a RDC Module, skip to Step Five.

Step Three: Disconnect the factory connector from the RDC Module.

Step Four: Connect the (e) Trigger Harness to the RDC Module by plugging the Female Connector of the Trigger Harness into the Male Port.

Step Five: Plug the bike's RDC Harness into the Male Connector of the Trigger Harness.

NOTE: For bike's without a RDC Module, the harness is still present and labeled "RDC".

NOTE: DO NOT connect to the Speed Sensor.

3.2 - Connecting To The Battery

Step One: Remove the fuse from the fuse holder.

Step Two: Remove the battery Side Cover and disconnect the negative (-) terminal and positive (+) jump start stud. Battery removal is not required.

Step Three: Connect the DENALI wiring harness to the battery via the ring terminals. Be sure that the red wire lead with the in-line fuse holder goes to the positive (+) terminal of the battery.

Step Four: Re-install the fuse into the fuse holder.

Note: The fuse holder can reside behind the Side Cover for easy access, in the event of a blown fuse.

4. Mounting The Switch

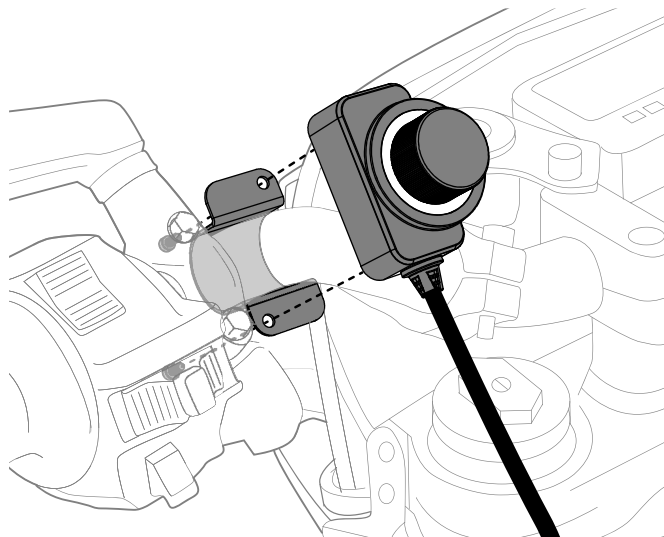

4.1 - Handlebar Mounting

The DialDim™ Switch includes a 7/8" band for mounting to handlebars, but also can be surface mounted. Follow the steps below for handlebar mounting, or continue to *Section 4.2* for surface mounting instructions.

Step One: Place the band around the handlebar.

Step Two: Use the two M3.5 screws and a 3mm allen key to attach the switch to the mounting band. Continue tightening the screws until the switch no longer rotates on the handlebar.

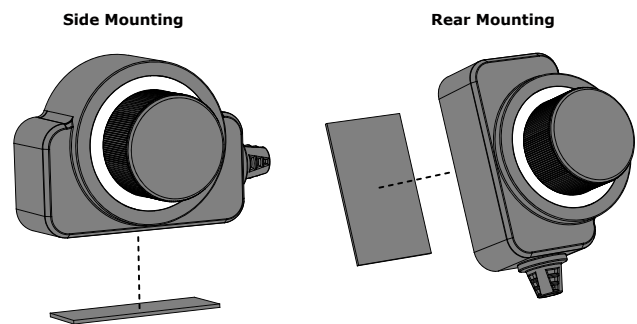

4.2 - Surface Mounting

The DialDim Switch is designed to be surface mounted in two different orientations, side mounted or rear mounted.

Step One: Clean and prep the mounting surface and the bottom of the switch using an alcohol swab. Allow surfaces to fully dry.

Step Two: Adhere the switch to the mounting surface using double stick tape. We recommend using 3M VHB tape.

Note: To ensure a stronger bond use a heat gun to warm the tape before applying to the surface.

1 **Circuit One**
 ON Single Click
 OFF Press & Hold

SWITCH CIRCUITS
 Double Click

2 **Circuit Two**
 ON Double Click
 OFF Press & Hold

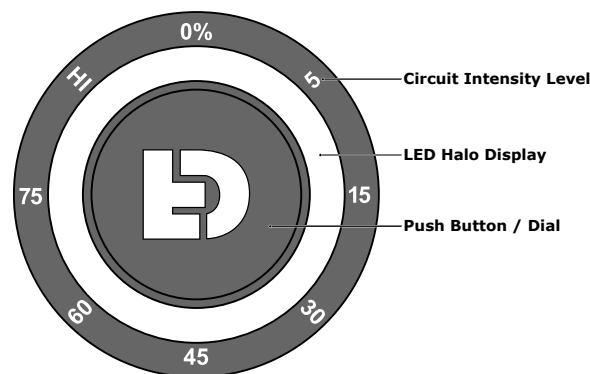

5.1 - Controlling the Lights

Our ground-breaking DialDim™ Lighting Controller features a multicolor halo dimming switch that allows you to independently turn on/off and dim two sets of auxiliary lights from a single consolidated wiring harness. The LED halo switch displays your exact settings and allows for effortless dimming on the fly. The blue halo controls light set one and the green halo controls light set two.

Light Set One (Blue Halo):
 Single Click **ON** --> Press & Hold **OFF**

Light Set Two (Green Halo):
 Double Click **ON** --> Press & Hold **OFF**

Increase Intensity:
 Rotate Dial Clockwise

Decrease Intensity:
 Rotate Dial Counterclockwise

Switch Between Circuits:
 Double Click

6. Fuse Setting Controls

F **ENTER** Hold for 7
EXIT Hold for 2

SWITCH CIRCUITS
 Double Click

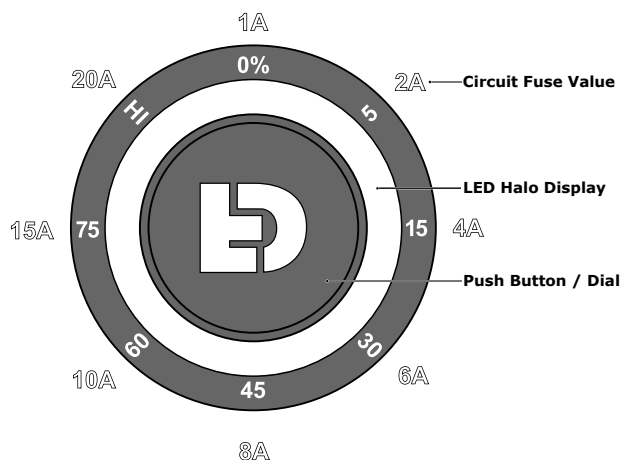

6.1 - Setting The Electronic Fuses

Both light circuits are electronically fused and can be set right from the switch itself! The halo will illuminate red to notify you when a circuit is fused is tripped.

Enter Fuse Setting Mode:
 7 Second hold

Increase Fuse Value:
 Rotate Dial Clockwise

Decrease Fuse Value:
 Rotate Dial Counterclockwise

Switch Between Circuits:
 Double Click

Exit Fuse Setting Mode:
 2 Second Hold

6.2 - Recommended Fuse Values

Refer to the list below for the recommended fuse value for a pair of DENALI light pods.

- DM Light Pods** - 4A
- D2 Light Pods** - 4A
- D3 TriOptic Light Pods** - 6A
- D3 Fog Light Pods** - 6A
- DR1 Light Pods** - 4A
- S4 Light Pods** - 8A
- D4 Light Pods** - 10A
- D7 Light Pods** - 15A

For other lights not listed above, a good general rule of thumb for choosing the correct fuse value is to multiply the power draw (Amps) by 1.5 and then rounding up or down to the closest value fuse.



8 Flashing Green LEDs
Vehicle battery voltage above 11.8v



8 Flashing Red LEDs
Vehicle battery voltage below 11.8v



4 Flashing Red LEDs
Vehicle battery voltage below 10.8v

7.1 - Start Up Flash Sequence

The switch halo doubles as a battery monitor with a low-voltage cutoff feature. Upon keying on the vehicles ignition, the halo will flash different colors to display your current battery health. If voltage is below 10.8v the auxiliary lights will not power on, saving you enough battery power to turn the engine over. Once the battery charges above 10.8v the lights will return to normal operation.

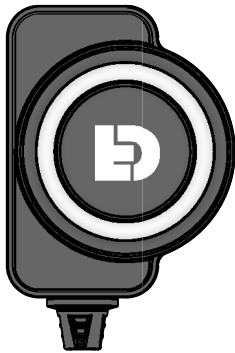

No LEDs
Both Circuits powered OFF

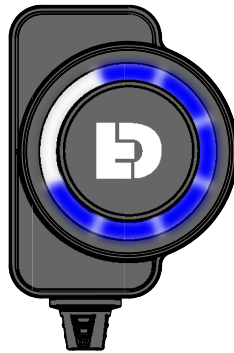

Solid Blue LEDs
Light Circuit One dimming control and intensity display

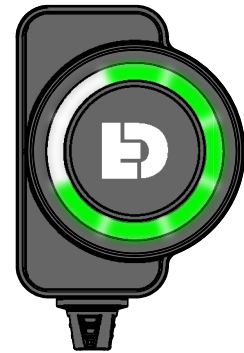

Solid Green LEDs
Light Circuit Two dimming control and intensity display

7.2 - Auxiliary Light Status and Control

The switch halo displays the exact intensity of both of your lights so you're never stuck guessing if your lights are on, or what intensity they're set to. Simply double click to switch between the two circuit intensity displays, or press and hold to turn light circuits off.

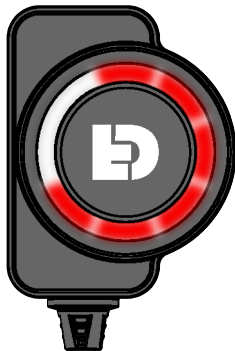

Solid Red LEDs
Fuse Tripped



Flashing Blue LEDs
Light Circuit One fuse setting mode



Flashing Green LEDs
Light Circuit Two fuse setting mode

7.3 - Fuse Status and Setting

Thanks to the electronically fused circuits, the halo switch can also display, and allow you to select, the fuse values for each circuit. And if a fuse trips, the LED halo will turn red providing real time feedback and allow for resetting the fuse.