



Switched Power Wiring Harness Ducati DesertX DNL.WHS.24200



Thank you for choosing DENALI

We know you would rather be riding your bike than wrenching on it, so we go the extra mile to make sure our instructions are clear and as easy to understand as possible. If you have any questions, comments, or suggestions don't hesitate to give our experts a call at 401.360.2550 or visit WWW.DENALIELECTRONICS.COM

Please Read Before Installing

DENALI products should always be installed by a qualified motorcycle technician. If you are unsure of your ability to properly install a product, please have the product installed by your local motorcycle dealer. DENALI takes no responsibility for damages caused by improper installation. **Caution:** When installing electronics it is extremely important to pay close attention to how wires are routed, especially when mounting products to the front fender, front fork, or fairing of your motorcycle. Always be sure to turn the handlebars fully left, fully right, and fully compress the suspension to ensure the wires will not bind and have enough slack for your motorcycle to operate properly.

Installation Tips

We strongly recommend using medium strength liquid thread locker on all screws and bolts. It is also important to ensure that all hardware is tightened to the proper torque specifications as listed in your owner's manual. For included accessory hardware please refer to the default torque specifications provided below. Inspect all hardware after the first 30 miles to ensure that proper torque specifications are maintained.

Bolt Size	in-lbs	ft-lbs	Nm
M3	10.0 in-lbs	-	1.0 Nm
M4	23.0 in-lbs	-	2.5 Nm
M5	44.5 in-lbs	3.5 ft-lbs	5.0 Nm
M6	78.0 in-lbs	6.5 ft-lbs	9.0 Nm
M8	-	13.5 ft-lbs	18.0 Nm
M10	-	30.0 ft-lbs	41.0 Nm
M12	-	52.0 ft-lbs	71.0 Nm

Hardware Sizing Guide

Not sure what size bolt you have? Use this ruler to measure screws, bolts, spacers, etc. Remember, the length of a screw or bolt is measured from the start of the "mounting surface" to the end of the screw, so only include the screw head when measuring countersunk screws.

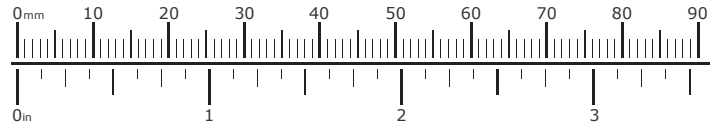

What's In The Box?



Kit Contents

- (a) Switched Power Wiring Harness (Ducati DesertX).....Qty 1

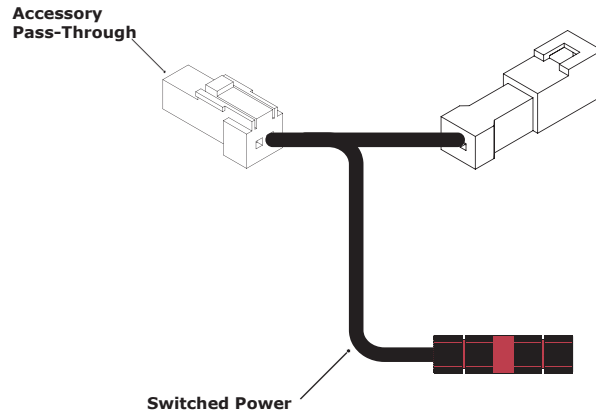

1.1 - Overview of Harness

This Switched Power Wiring Harness enables plug-&-play connection that provides Switched Power to DENALI LED Lights, like the Front T3 Switchback.

The pass through design allows for the Factory Ducati Accessory Pigtail to still be used for additional electronics, while powering accessory DRLs.

2. Installing The Harness

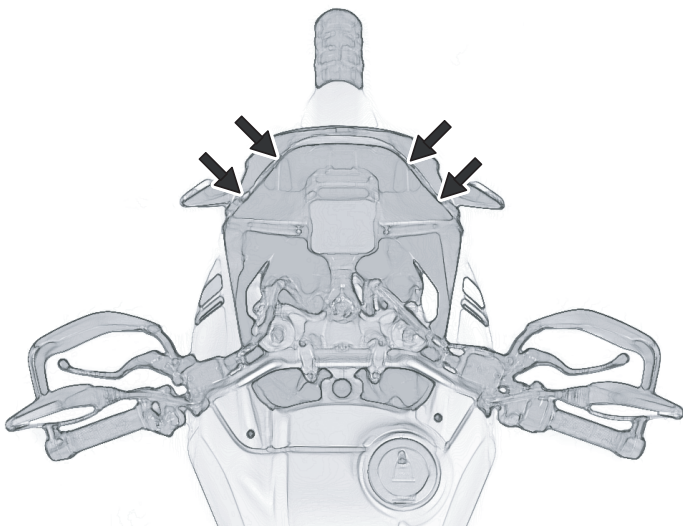

2.1 - Remove the Windscreen

Step One: Remove the (4) Screws that fasten the windscreen to the bike.

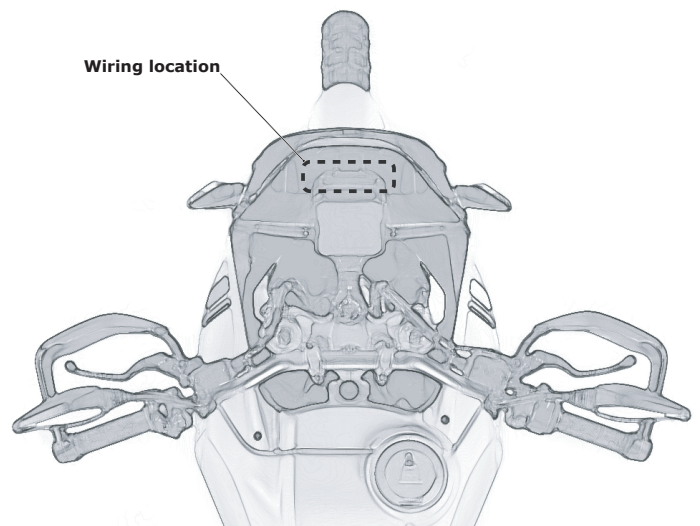

2.2 - Disconnect the Factory Pigtail

The Accessory Connector is stowed within the dash cavity. It is a White, 2-Pin, JWPF style connector with a sealed pigtail.

Step Two: Locate the Accessory Connector and disconnect the Factory Pigtail from the connector. Set the Factory Pigtail aside, so it can be reinstalled.

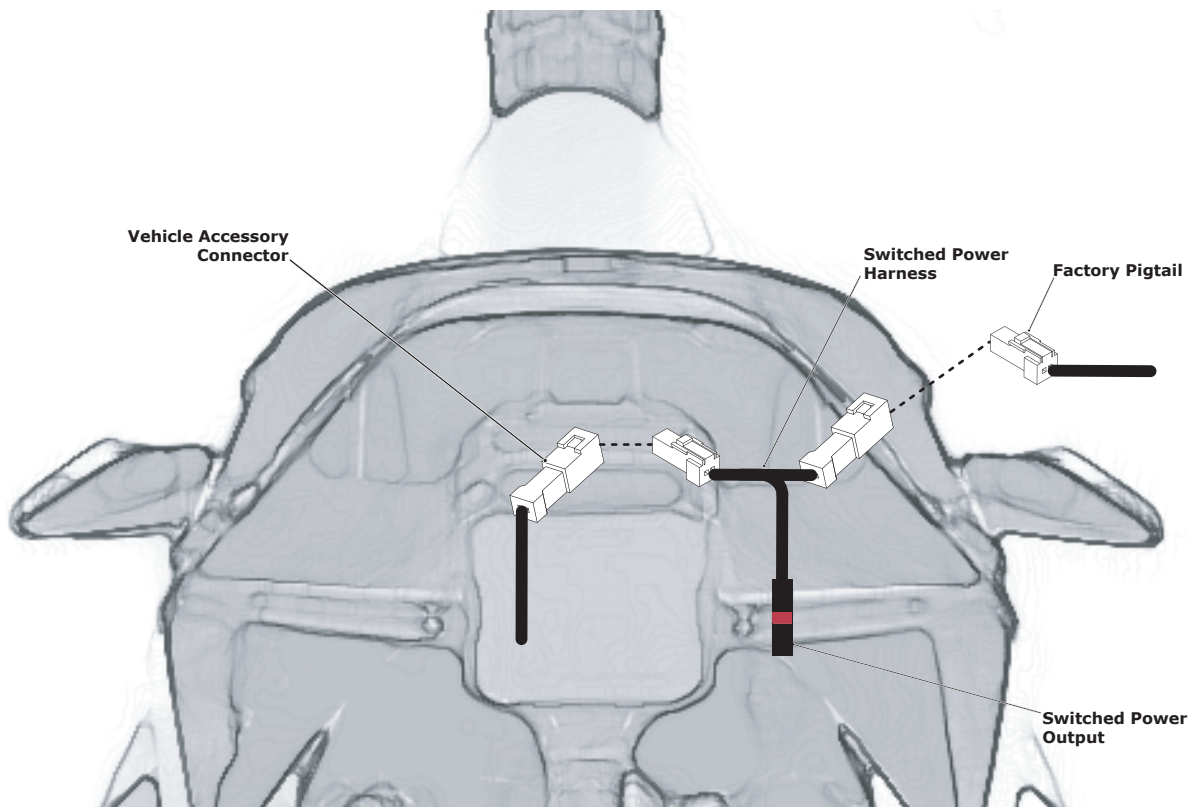

2.3 - Connect the Harness

Step Three: Plug the Switched Power Adapter Harness to the bike's Accessory Connector.

Step Four: Plug the Factory Pigtail into the Adapter Harness. This serves to seal the harness assembly, and can be used in the future for additional accessories.

3. Connect to Lighting

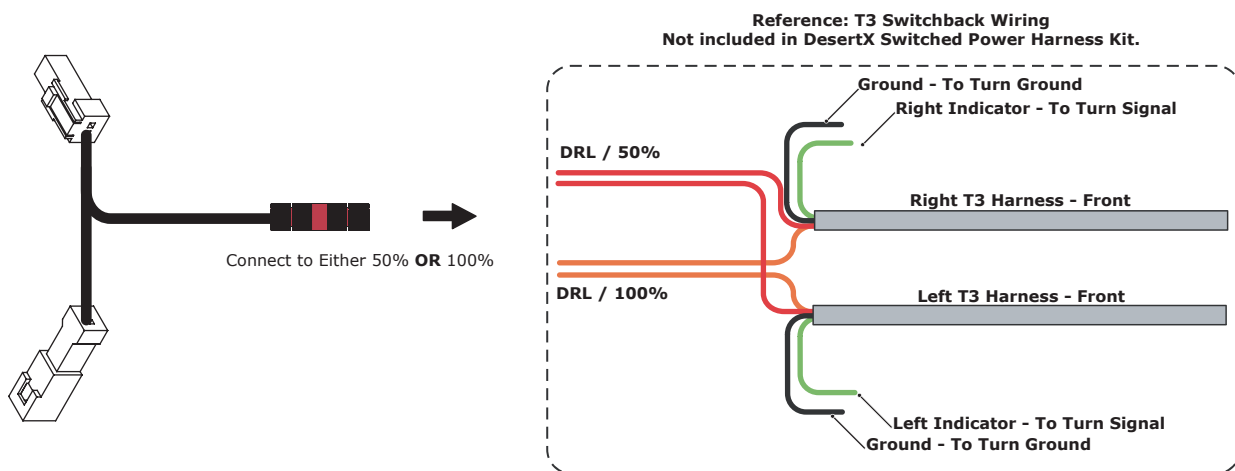

3.1 - Connect to Lighting

When installing lighting such as Front T3 Switchbacks, there is the opportunity to illuminate one of the DRL Circuits. This step shows how to provide power to either the High or Low circuit. See the T3 Instruction Manual for detailed steps.

Step One: Connect the Left and Right DRL wires to the Switched Power Harness, with the included POSILOCK. Connector to either the 50% OR 100% intensity.