



TTI

TODD TECHNOLOGIES INC

TTI Filter Cart

A portable filtration solution for decontaminating systems and transferring oils.





TTI Filter Cart

Filter Applications

- Clean-up of contaminated systems
- Treatment of new or repaired systems
- Pre-filtration of new oil
- Directly transfer oil without exposing it to contaminants

Standard Features

- Dial pressure gauges
- Pop-up filter replacement indicators
- Manual filter bypass
- Minimes[®] sample valve
- Y Strainer
- UL listed motor, and electricals
- 1" and 3/4" hoses

Customizable Features

- Fluid flow rate (2GPM, 5GPM, 10GPM)
- Hose connectors (ISO-A, ISO-B, MNPT)
- Filters (3 μ m, 6 μ m, 12 μ m, 25 μ m, Water Removal)

Performance

The TTI filter cart can filter oils up to ISO VG 680 at 40C/104F

Construction Materials

- Frame: Carbon steel
- Filter Heads: Aluminum
- Fittings: Zinc plated steel, stainless steel, brass
- Pumps: Aluminum, steel
- Hoses: Clear PVC with steel wire
- Gaskets: Buna-N

Filter Indicators

- Filter indicator pops at 20 psid/1.5 bar to notify the filters need to be replaced

Pump Relief

- Opens at 65psi/4.14 bar

Weight

- Approximately 125lbs/57kg, depending on options selected

Overall Dimensions

- 19"L x 23"W x 46"H

Contact us for more options

TTI Filter Cart

By the Numbers:

Item No.	Description	Qty.
①	Motor	1
②	Gear Pump	1
③	Filter Head	2
④	Pressure Gauge	1
⑤	Filter Element 1	1
⑥	Filter Element 2	1
⑦	Post-Filter Sample Valve	1
⑧	Pre-Filter Sample Valve	1
⑨	25' Cord	1
⑩	Suction Hose, 40"	1
⑪	Pressure Hose, 40"	1
⑫	Manual Filter Bypass Valve	1
⑬	Filter Bypass	1
⑭	Pump Relief-65psi	1
⑮	Filter Change Indicator	1

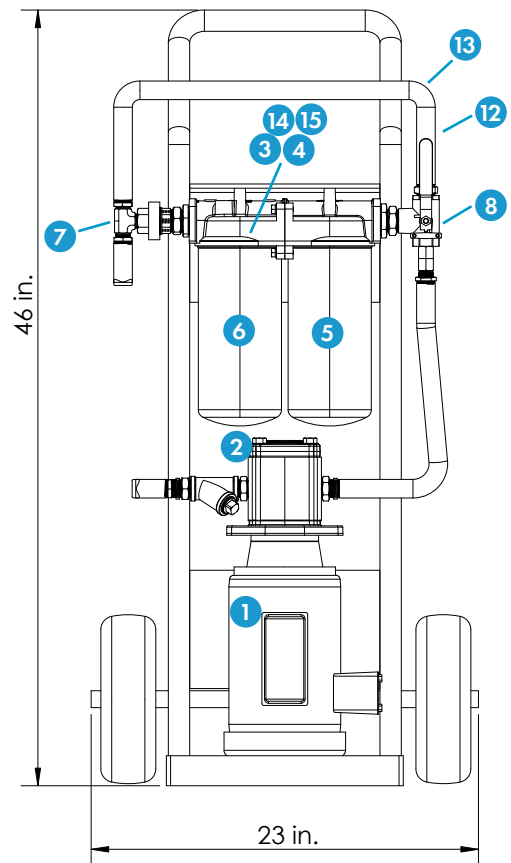
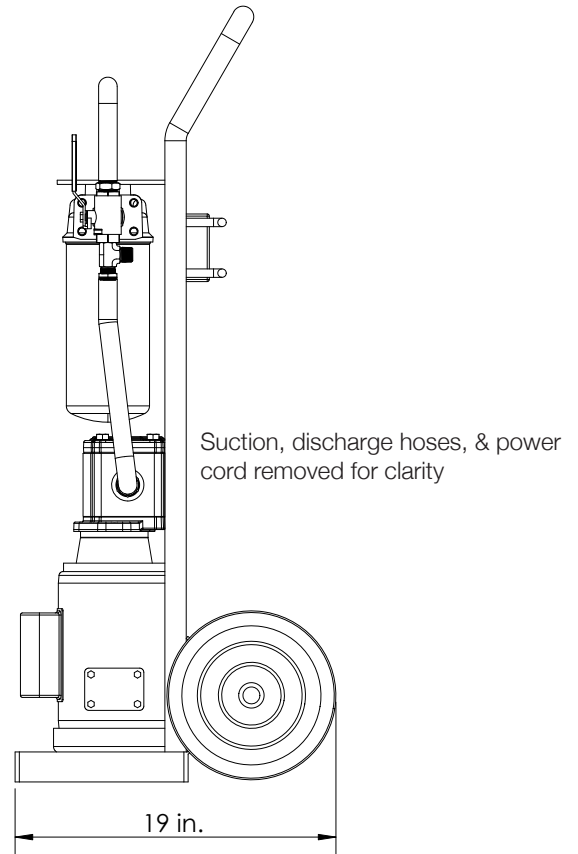



TTI Filter Cart

CUSTOMIZE YOUR FILTER CART

To order your TTI Filter Cart:

TTFC - [A] - [B] - [C] - [D]

Pump/Motor Combo [A]		Suction/Discharge Connectors* [B]		Filter 1 [C]		Filter 2 [D]	
2A	2GPM, 115V 60HZ 1PH	- A	ISO A	- L3	3µm	- L3	3µm
5A	5GPM, 115V 60HZ 1PH	- B	ISO B	- L6	6µm	- L6	6µm
10A	10GPM, 115V 60HZ 1PH	- N	MNPT	- L12	12µm	- L12	12µm
			*1" on suction side 3/4" on discharge side	- L25	25µm	- L25	25µm
				- LWA	Water Removal	- LWA	Water Removal

Replacement Filters - Microglass

Part Number	Micron Rating (Beta 1000)
TT-SFL-3	3µm
TT-SFL-6	6µm
TT-SFL-12	12µm
TT-SFL-25	25µm

Water Removal

Part Number	Micron Rating (Beta 1000)	Water Holding Capacity
TT-SFL-WA	25µm	15oz (425ml)

*All filter cartridges are 11"L

