

INSTALLATION GUIDE

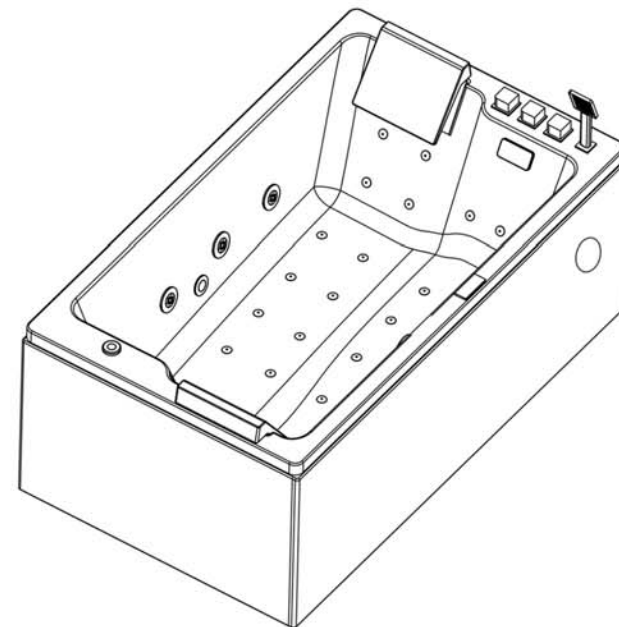

Bathtub



MASSAGE BATHTUB MANUAL MODEL:BT-62115B

Dear Users:

Thank you for choosing bathtubs. To secure safety, please read the instructions carefully before installation.

INDEX

CONTENT-----	1
Parts and Accessories-----	2
Electrical/Watery requirements-----	3
Water supply system installation-----	6
Bathtub installation-----	7
Operation manual -----	10
Maintenance -----	10
Safety instructions-----	11
Problems & Suggestions-----	11
Warnings-----	11

Note:

This manual does not equal letter of quality guarantee. The contents of this manual are subject to change with products update and revision.

Before installation, please read the water&electricity installation drawing, and pre-install the connector.

1、Parts and Accessories

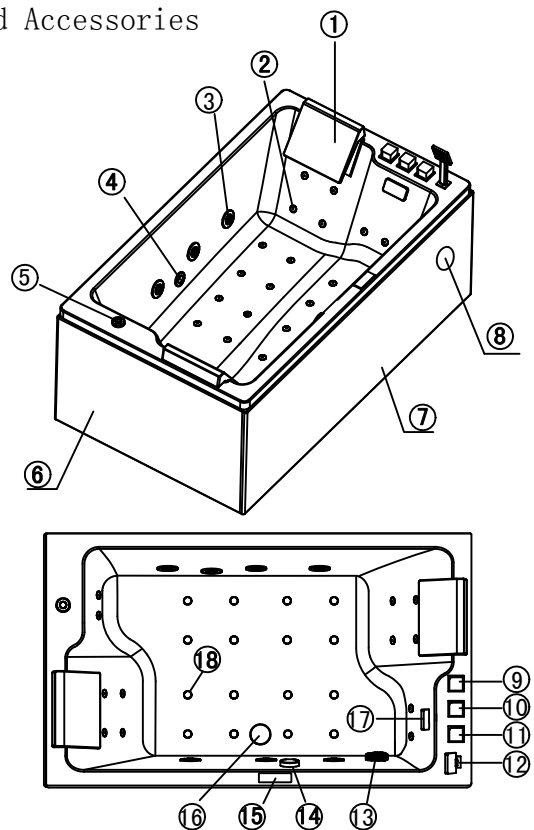

- | | | |
|---------------------|----------------------|--------------------|
| 1, pillow | 2, small jet | 3, big jet |
| 4, Underwater light | 5, regulating valve | 6, Small skirt |
| 7, Big skirt | 8, horn | 9, Hot water valve |
| 10, switch valve | 11, Cold water valve | 12, hand shower |
| 13, back water | 14, overflow | 15, panel |
| 16, drainer | 17, inlet | 18, Bubble nozzle |

8. Problems & Suggestions:

Problems	Cause	Suggestions
Water Pump Failure	Disconnect with power supply, leakage protector disconnect	Connect the power supply, connect leakage protector
	Plug disconnected	Connect plug
	Electricity supply abnormal	Inspect electricity supply
	Control box broken	Change it
	Pump impeller is blocked by Rubbish	Clean the pump
	Water Pump broken	Repair or change it
	Control panel failure	Change it
Air Pump Failure	Disconnect with power supply, leakage protector disconnect	Connect the power supply, connect leakage protector
	Plug disconnected	Connect plug
	Electricity supply abnormal	Inspect electricity supply
	Control box broken	Change it
	Pump impeller is blocked by Rubbish	Clean it
	Air Pump broken	Repair or change it
Water pump OK but no water out of jets	Control panel failure	Change it
	Pump impeller slipped	Change the impeller
Failure to control massage Strength	Water recycle device jammed or recycle line leakage	Clear water recycle or repair the leakage
	Voltage abnormal	Inspect the voltage
Bath tub surface uneven	Water recycle device jammed	Clean it
	Metal feet not balanced	Adjust the metal feet
Water pipe leakage	Seal failure	Change it
	Screw unlocked	Lock it
	Joint disconnected	Reconnect it
Skirt installation failure	Adjust the upper, lower, left, right side to fit screw holes	
	Disconnect with control box	Reconnect
Control panel failure	Control panel failure	Repair or change the panel
	Control panel broken	Change it

9. Caution:

- 9.1 Please check the above table first in case of any function failure.
- 9.2 The massage bathtub is used in a very humid environment. Although the manufacturer already considers the safety measures in production, the electrical installation should be conducted by qualified electrician. Meanwhile, a reliable leakage circuit-breaker must be used and ground wire should be connected.

6. Cleaning and maintenance:

- 6.1 Clean with soft cloth and light detergent. Any detergent with acetone or ammonia elements is forbidden. It is also forbidden to use any sterilization solution that contains formyl and formaldehyde.
- 6.2 A scar or scratch on the surface can be first polished by 2000# wet sandpaper, then applied with toothpaste and then finally cleaned and polished by soft cloth.
- 6.3 The lime scale or dirt on the surface can be cleaned up with light acid detergent, such as lemon juice, heated wax with soft cloth wiped.
- 6.4 The backflow cover can be taken off to clean in case getting stuff or dirty.
- 6.5 Chromed parts need not wiping too often.
- 6.6 Don't use a rough tool or sanded detergent with chemical dissolvent to clean the bathtub.
- 6.7 Drain water completely and power off after use
- 6.8 Don't strike or scratch the surface. Avoid any burning cigarette or hot stuff above 70°C touching the surface.
- 6.9 Massage system cleaning: fill the bathtub with 40°C warm water, pour in detergent at rate of 2 gram per liter of water, start massage system, turn it off after 5 mins, drain the water. Then fill the bathtub with cold water, start massage system, turn it off after 3 mins, drain the water, and finally clean the bathtub.

7. SAFETY INSTRUCTIONS:

- 7.1 Electric components should be installed by professional electrician under the guide of this manual.
- 7.2 Electric parameters should be conformable with national standards. The power wire should have leakage protector and be connected with ground wire. The switch, plug and socket should be water proof.
- 7.3 Don't use too hot water. When filling the bathtub, cold water should be ahead of hot water. Don't start water pump until water level reaches the jets.
- 7.4 Cut off power after use.
- 7.5 The duration use of the massage is better to be controlled within 30mins.

2、Electrical/Watery requirements

2.1 Switch controled by main power supply: Install a small circuit breaker which has electricity leakage protection and with 32A anti-water. It can be installed in a place that can be easily operated. Please cut off the power supply after every usage, to make sure the computer control system safety. (shown as following A)

2.2 power supply: rated voltage 220V/50Hz, 16A anti-water socket, three-core 4 mm² copper cable. The socket should be placed as out as possible, which is convient for maintenance. (shown as following B)

2.3 water supply: G1/2 cold-hot water hose each, both hoses should be installed with shut-off valve. (shown as following C)

2.4 Draining: try to focus on draining position shown in the drawing. If not, the drainer should be placed within 200mm from drainer position, and the dimaetere should be less than 50mm (shown as following D)

2.5 Maintenance area: Please leave space 500mm or more around the bathtub for future maintenance. Please do not install any fixed objects in this free area. (shown as following E)

Note:

The water pressure of this product must be between 0.1-0.4MPA. It may influence the function of the product if out of this range.

Please install the booster pump if water pressure is too low (please prepare the booster pump by yourself).

ELECTRICAL SPECIFICATIONS

Appliance Name	Rated Voltage	Rated Hertz	Rated Watt
Water pump	AC220V-240V	50/60Hz	1125W
Air pump	AC220V-240V	50/60Hz	450W
The heating apparatus	AC220V-240V	50/60Hz	1500W

Electrical/Watery Diagram

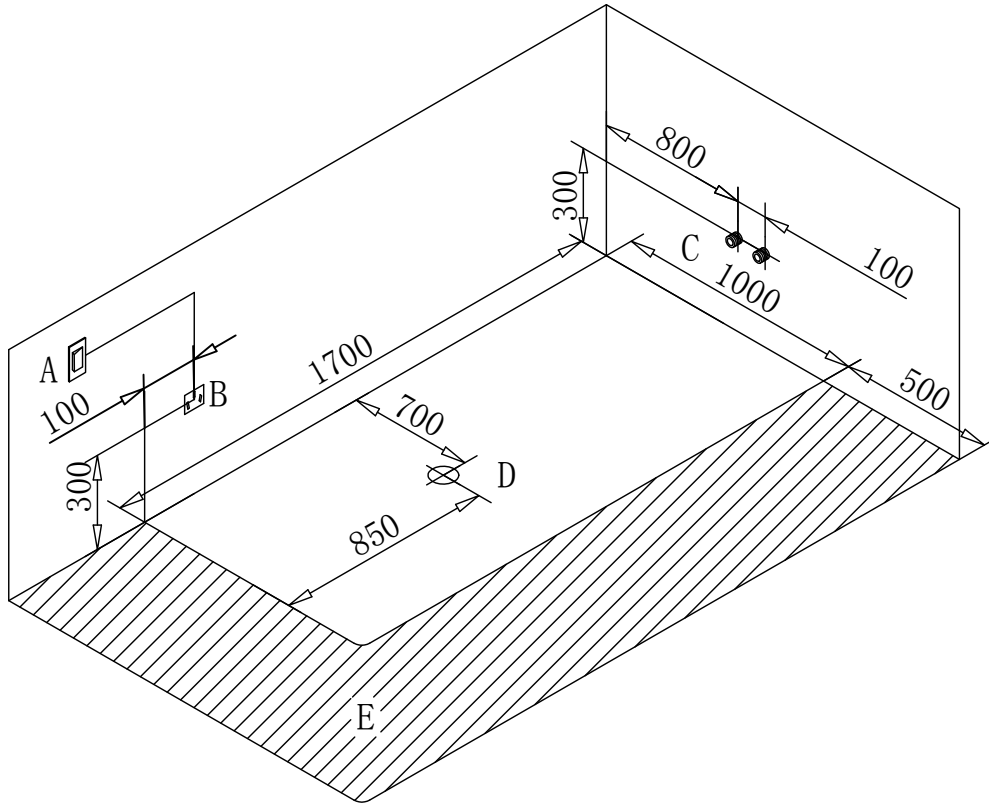

R

5.3.4 Water pump surf

5.3.4.1 The water checking device of this controller protects the water pump from burning out.

5.3.4.2 Press , till the cursor moved to while the water level achieves the setting value ,and then press to start the pump, the cursor blinks press again, Water pump surf is stopped.

5.3.4.3 When the water level lowers than the setting value, pump stops working.

5.3.4.4 When the water surf pump function is on, and the system checks the water level lower than the setting value, water surf pump function stops automatically, at the same time the pump icon blinks. When any time the system checks the water level achieves the setting value, the icon stops blink and the pump starts to work.

5.3.5 Thermostatic heating

5.3.5.1 This functions works only when the water pump surf function is on.

5.3.5.2 Press , till the cursor moved to and then press to start the thermostatic heating function.

5.3.5.3 Press again to stop the function.

5.3.5.4 Temperature adjustment, When the thermostatic heating function is on,

press till “C” on LCD blinks, then press or to adjust the temperature. During the adjusting, LCD displays the setting temperature, then the temperature shall be increased /decreased 1 °C after press or

once pressing or more than 2S, temperature will increase or decrease by “1°C /0.5s” stop adjusting for 5 seconds, LCD shall display the current water temperature.

5.3.5.5 Temperature setting range: 35°C--45°C.

5.3.5.6 If the temperature sensor occurs error, LCD displays “E1” and the controller sounds “di...di...”, in this case the heater cannot be start.

5.3.6 Eternal blue tooth modules

5.3.6.1 when the system is on, press continuously , till the cursor is on .Press“ to turn the eternal blue tooth module on and the LCD will display “BT” press again“ to turn the eternal blue tooth module off.

5.1 Switch functions

5.1.1 Adjust hot water valve (as pic 9) and cold water valve (as pic 11) respectively to obtain hot or cold water. And adjust 9 and 11 together to obtain an appropriate temperature.

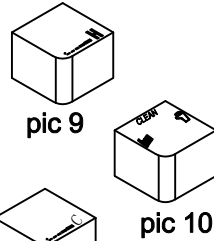

5.1.2 Turn the diverter switch to choose either waterfall spout or hand shower. (as pic 10).

5.1.3 Make sure to turn off hot and cold valves after use.

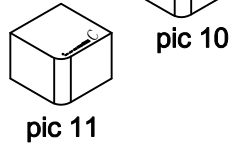

5.2 Water massage:

5.2.1. During the massaging, use the D switch to control the massage power, we can lower the power while clockwise.

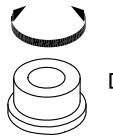



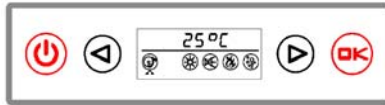

5.3 Computer control panel operations:







5.3.1 Power

Press  for 2 seconds to start the controller, at the same time, the lamp is turned on. Press the icon again to stop the controller and all the loads are turned off.

5.3.2 Lamp

When the system is on, press continuous  ,  , till LCD displays  then press  lamp is turned on. Press  again, lamp is turned off.

5.3.3 Blower

Press  ,  , till the cursor is moved to  , Press  each time to increase the speed of the blower by one degree. The symbol in LCD will be blink. Press  the fourth time to stop the blower, the symbol in LCD will be statically displayed.

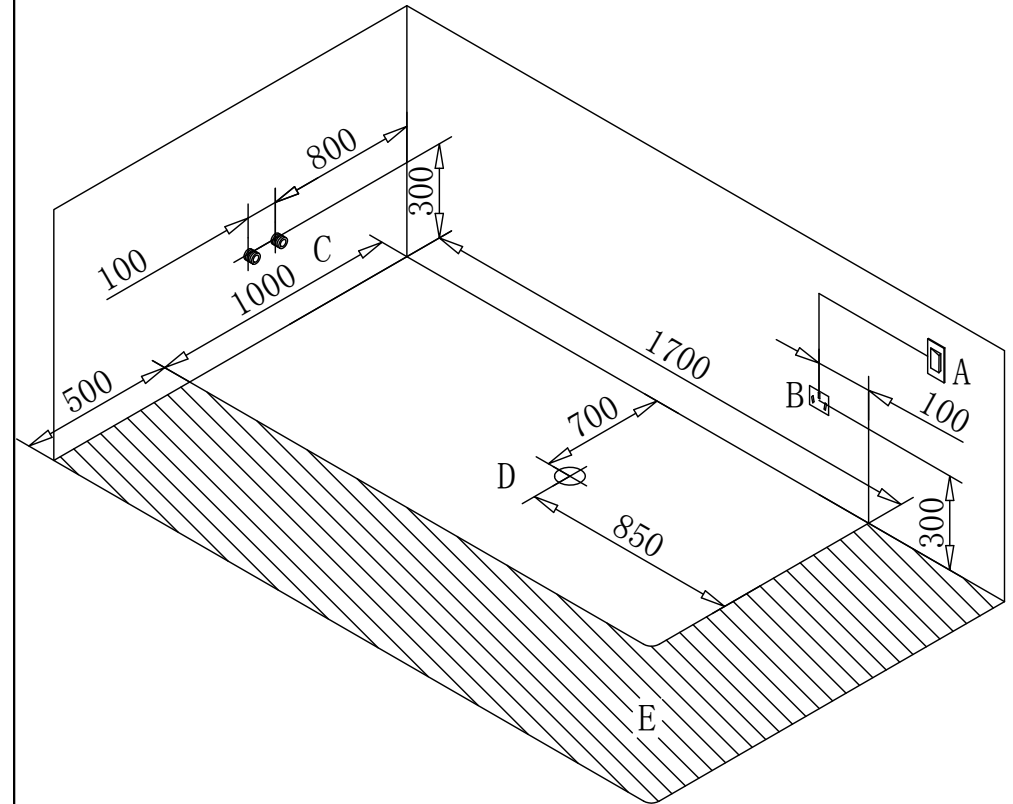

L

The power cable should be installed with leakage protector and connected to the ground. The cross section area of power cable should at least 2.5 square mm or above. The power supply facility should conform to national safety standard (please prepare the leakage protective switch by yourself), and the protective ground wire should be connected with the massage bathtub iron hob, where there is a symbol for ground wire.

3. Water supply system installation

3.1 Water supply diagram

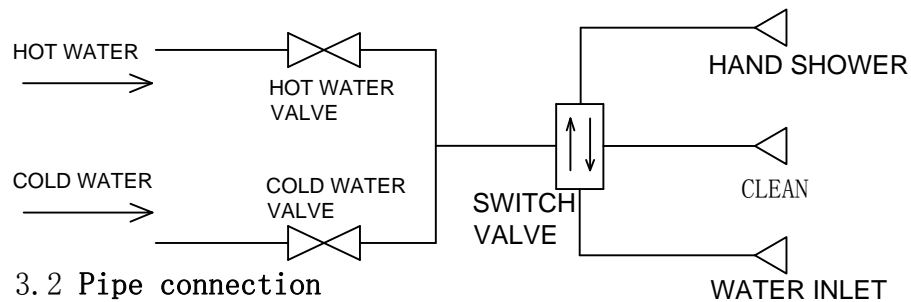

3.2 Pipe connection

3.2.1 Water supply

The parts have been assembled in factory, so you only need to connect the cold and hot water hose with corresponding water pipes or connectors. The connection joints are better to be placed in the back invisible area of the bathtub.

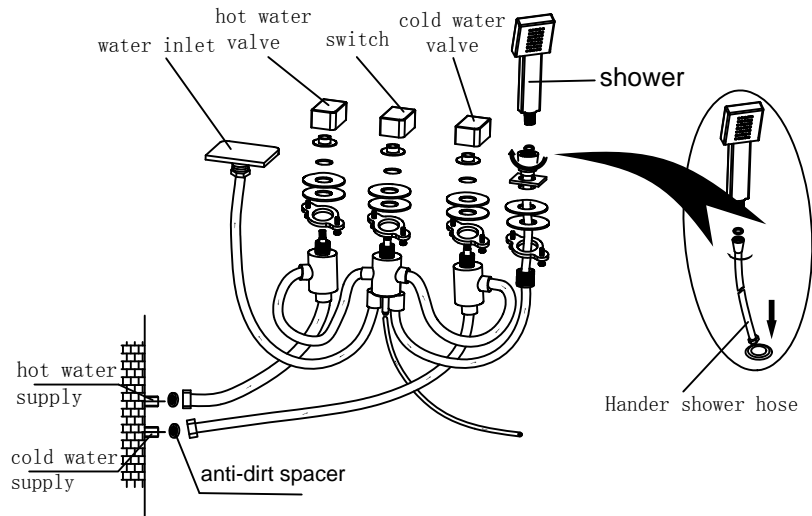

3.2.2 Drainage

Adjust screws of the bottom stands to balance bathtub body.
Connect the bathtub drainage with the drainage pipe, and then connect the pipe with ground drainage hole. Apply glue as well.

As shown in below diagram

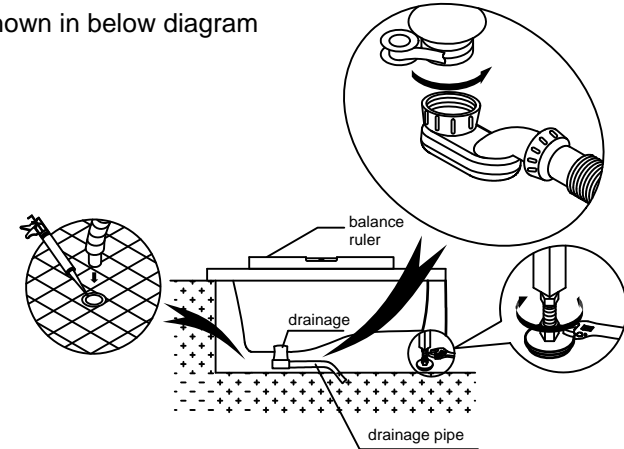

4. Bathtub installation

4.1 Bathtub skirts installation

4.1.1 Handle with care during installation so as to avoid scratches.

4.1.2 Connect the drainage switch with the drainage pipe, and a soft pipe may be used in case of a deviation between the drainage pipe and the ground hole.

4.1.3 Take down the screws, ornament cover and plastic gaskets, and then take out the skirt board.

4.2 Adjust screws of foot stand to place bathtub horizontally.

4.3 Finally fix the skirt board as per the diagram. First insert the skirt board between the bathtub edge track and the fixed plastic board, and then fix it with screws

