

	<p>特性 FEATURES</p> <p>40A&60A 触点切换能力 具有三种形式 防尘罩和塑封型可供选择 外形尺寸: 26×26×25mm</p> <p>40A&60A Switching capability 3 kinds of contact arrangement available Dust protected Type And Sealed Type Available Outline dimensions: 26×26×25mm</p>
---	---

触点参数 CONTACT PARAMETERS

触点形式 Contact Arrangement	1A、1C	2A
触点材料 Contact Material	银合金 Silver Alloy	
接触压降 Voltage Drop(初始 Initial)	典型值 Typ. 20mV, 最大值 Max. 250mV (at 10A)	
最大连续电流 Maximum continuous current	NO/NC:40A/30A	NO/NC:60A/45A NO:2×20A
最大切换电压 Max. Switching Voltage	80VDC	
电气寿命 Electrical Life	见附表 1 See schedule 1	
机械寿命 Mechanical Life	1×10 ⁶ 次 OPS	

性能参数 CHARACTERISTICS

绝缘电阻 Insulation Resistance	100MΩ (500VDC)
介质耐压 Dielectric Strength	触点与线圈间 Between Coil & Contacts: 500VAC 1min
	断开触点间 Between Open Contacts: 500VAC 1min
动作时间 Operate Time	≤10ms
释放时间 Release Time	≤5ms
环境温度 Ambient Temperature	-40°C ~ +125°C
振动 Vibration	10Hz~500Hz, 49m/s ² (5G)
冲击 Shock	稳定性 Functional: 98m/s ² (10G)
	强度 Destructive: 196m/s ² (20G)
引出端方式 Terminal Form	快速接式引出端 OC
封装形式 Construction	防尘罩型 Dust Protected, 塑封型 Sealed
重量 Unit Weight	约 Approx. 33g
机械性能 Mechanical Data	外壳保持力: (拉和压) 200N Cover Retention: (Pull & Push) 200N
	引出脚保持力: (拉和压) 100N Terminal Retention: (Pull & Push) 100N
	引出脚抗弯曲力: (各方向) 10N Terminal Resistance To Bending: (Front & Side) 10N

附表 1 SCHEDULE 1

负载电压 Load Voltage	负载类型 Load Type		触点负载电流 Load Current (A)			通断比 On/Off Ratio S		电耐久性 (次) Electrical Endurance OPS	试验环境温度 Ambient Temp.
			1C		1A	接通 On	断开 Off		
			常开 NO	常闭 NC	常开 NO				
14VDC	阻性 Resistive	接通 Make	40	30	40	2	2	1 × 10 ⁵	详见电耐久性实验环境温度曲线 See Ambient Temp. Curve
		断开 Break	40	30	40				
	感性 Inductive	接通 Make	150	-	150	2	2		
		断开 Break	30	-	30				
	灯 Lamp	接通 Make	80	-	80	2	2		
		断开 Break	30	-	30				
28VDC	阻性 Resistive	接通 Make	30	20	30	2	2	At 23°C	
		断开 Break	30	20	30				

注意：1) 触点无负载电流、线圈电阻为最小值情况下，继电器线圈允许施加的最大连续工作电压。

1) Max. Allowable overdrive voltage is stated with no load applied minimum coil resistance.

线圈规格表 COIL DATA(23°C)

额定电压 Rated Voltage VDC	动作电压 Operate Voltage VDC	释放电压 Release Voltage VDC	线圈电阻 Coil Resistance Ω±10%	线圈功率 Coil Power W	并联电阻 Parallel Resistance Ω±10%	等效电阻 Equivalent Resistance Ω±10%	允许最大线圈电压 ¹⁾ Max Allowable Overdrive Voltage VDC	
							23°C	85°C
12	≤8.4	≥1.2	85	约 Approx. 1.7	-	-	20.2	15.7
12	≤8.4	≥1.2	85	约 Approx. 1.9	680	75.5	20.2	15.7
24	≤16.8	≥2.4	340	约 Approx. 1.7	-	-	39.5	31.5
24	≤16.8	≥2.4	340	约 Approx. 1.9	2700	302	39.5	31.5
24	≤16.8	≥2.4	255	约 Approx. 2.3	-	-	39.5	31.5

订货标记示例 ORDERING INFORMATION

	MAH3	-S	-1	12	-C	-1	R
产品型号 Model:	MAH3						
产品结构 Structure:	无 Nil: 防尘罩型 Dust Protected S: 塑封型 Sealed						
触点组数 Contact Group:	1: 1 组 Group						
线圈电压 Coil Voltage:	12: 12VDC 24: 24VDC						
触点形式 Contact Form:	A: 常开 NO B: 常闭 NC C: 转换 NO/NC						
结构型式 Version	1: 光背快速接引出端 Cover Without Bracket 2: PCB 引出端 PCB layout 3: 铁背快速接引出端 Cover With Metal Bracket 4: 塑背快速接引出端 Cover With Plastic Bracket 5: 防水外壳 Waterproof Enclosure						
线圈并联电阻 Coil Derived Resistance	无 Nil: 无并联元件: No: Components D1: 并联二极管(阳极接 86#脚)With Parallel Diode (anode connection pin # 86) D2: 并联二极管(阳极接 85#脚)With Parallel Diode (anode connection pin # 85) R: 并联电阻 With Resistor						

外形尺寸、接线图 OUTLINE DIMENSIONS AND WIRING DIAGRAM (单位 Unit: mm)

MAH3-1□□-□-1□

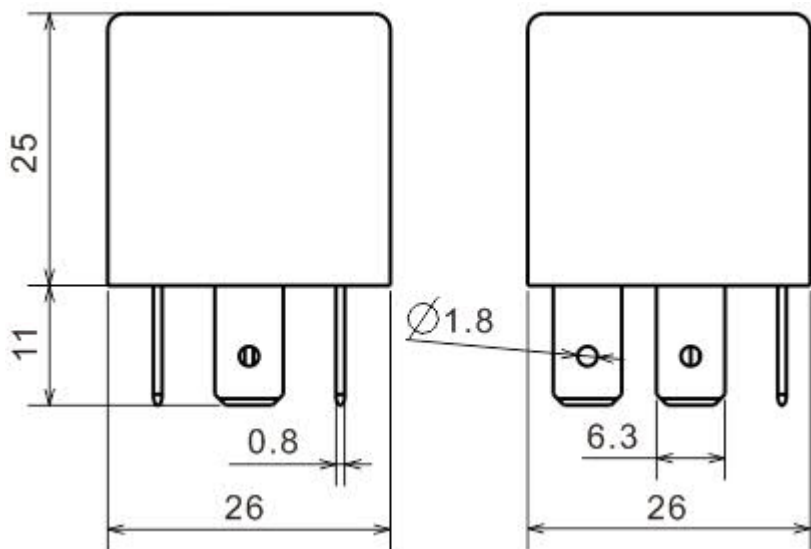
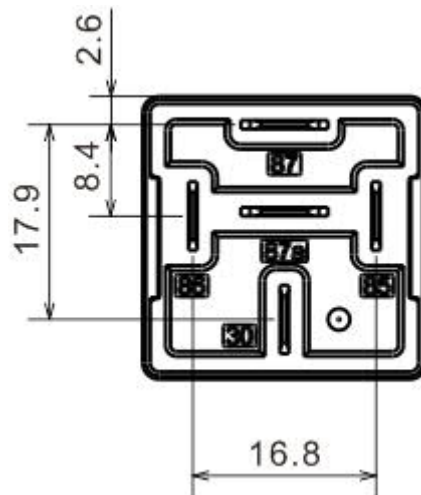
外形尺寸 Outline Dimensions

(底视 Bottom View)

MAH3-1□□-□-3□

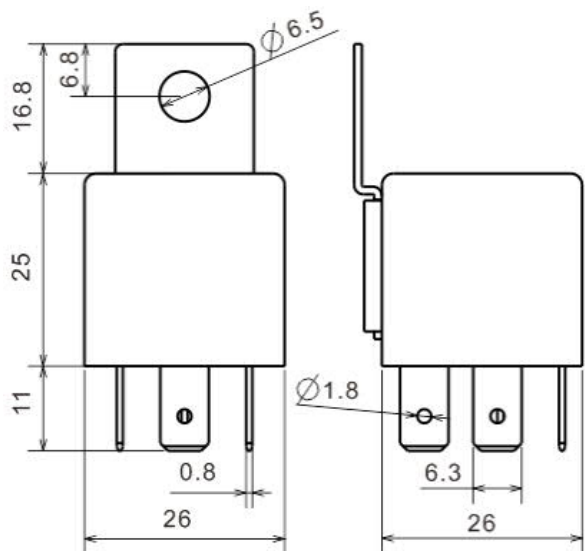
外形尺寸 Outline Dimensions

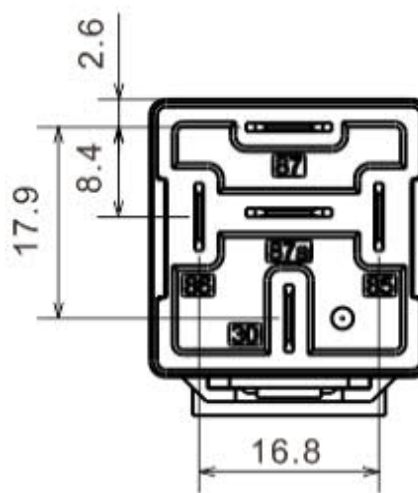

(底视 Bottom View)



MAH3-1□□-□-4□

外形尺寸 Outline Dimensions

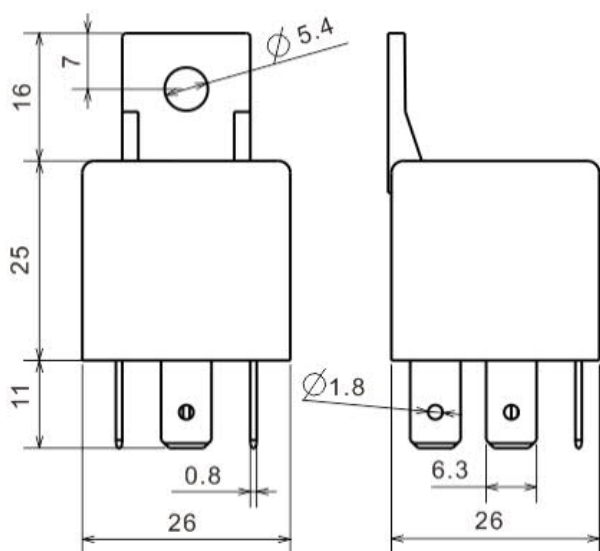

(底视 Bottom View)

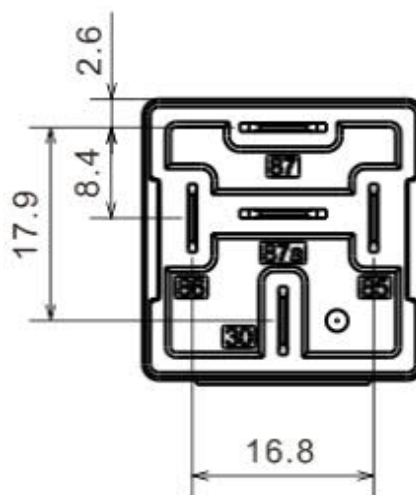

MAH3-1□□-□-5□

外形尺寸 Outline Dimensions

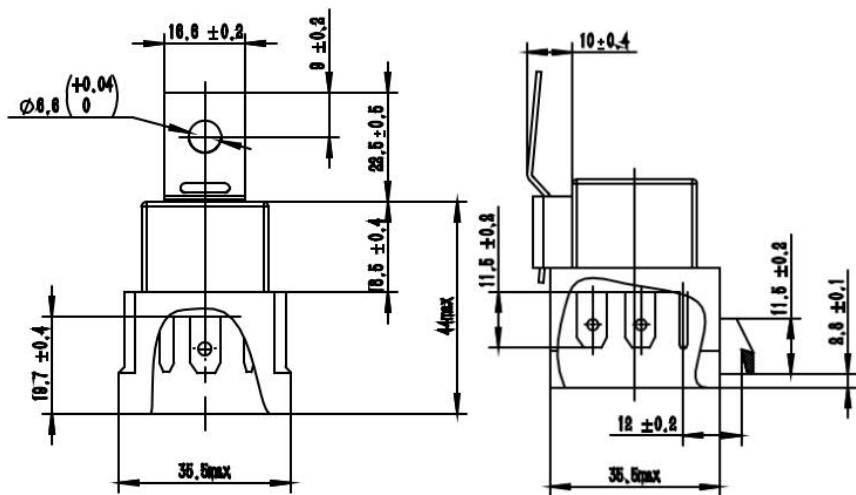

(底视 Bottom View)

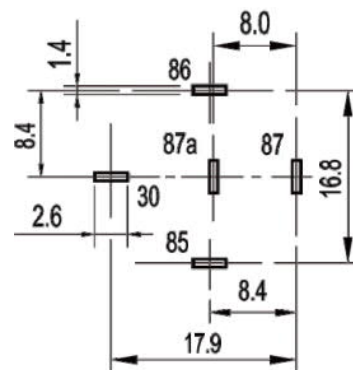

备注:

产品部分外形尺寸未注尺寸公差, 当外形尺寸 ≤ 1mm, 公差为 ± 0.2mm; 当外形尺寸在 1~5mm 之间时, 公差为 ± 0.3mm; 当外形尺寸 > 5mm 时, 公差为 ± 0.4mm;

REMARK:

In case of no tolerance shown in outline dimension: outline dimension ≤ 1mm, tolerance should be ± 0.2mm; outline dimension > 1mm and ≤ 5mm, tolerance should be ± 0.3mm; outline dimension > 5mm, tolerance should be ± 0.4mm;

接线图 Wiring Diagram

MAH3-□-1□□-□-□

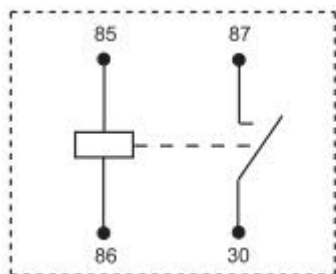

1A

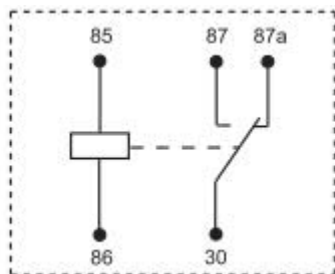

1C

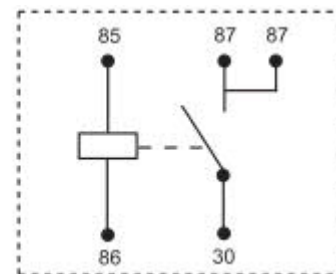

2A

MAH3-□-1□□-□-□D1

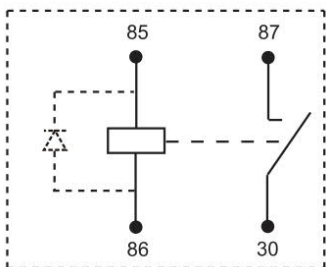

1A

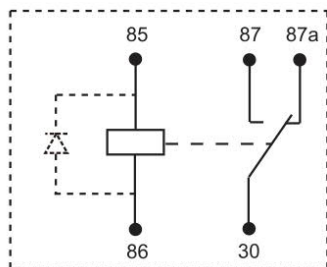

1C

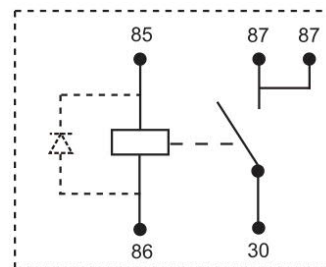

2A

MAH3-□-1□□-□-□D2

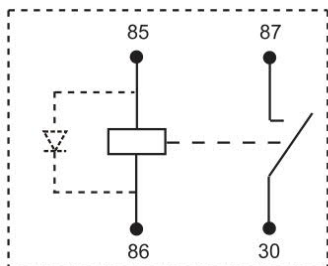

1A

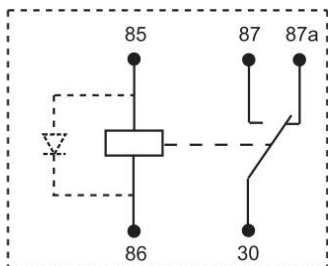

1C

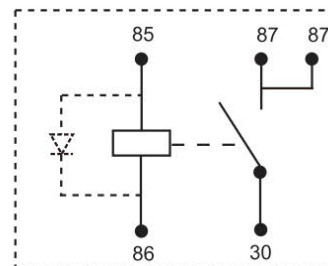

2A

MAH3-□-1□□-□-□R

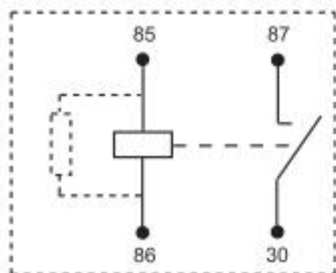

1A

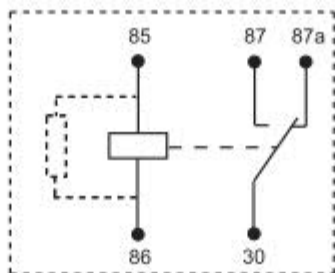

1C

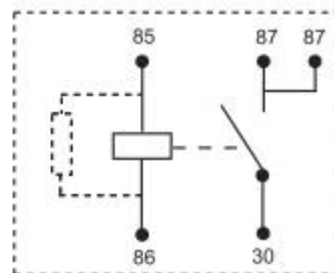

2A

性能曲线图 PERFORMANCE CURVE

1. 线圈连续通电电压范围
Coil Operating Voltage Range

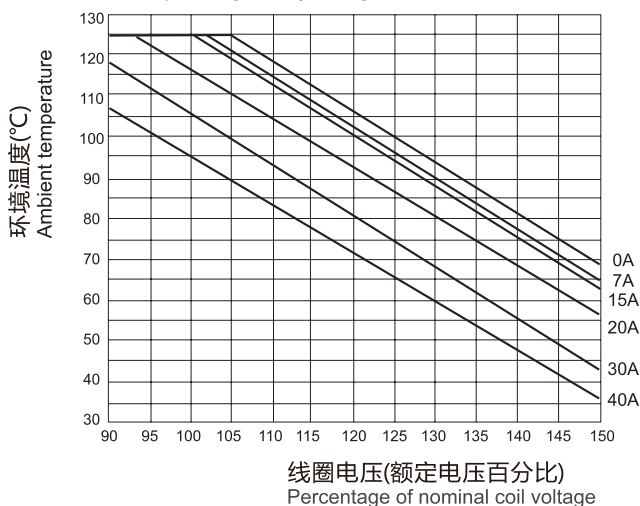

说明：

- (1) 继电器线圈施加最大连续工作电压时，触点应没有负载。
 - (2) 动作电压与线圈预通电时间、预通电电压有关，在预通电后检测动作电压，其值会变大。
 - (3) 线圈最大允许温度为180°C，考虑到电阻法所测量的线圈温升是平均值，推荐在不同使用环境、不同线圈电压、不同负载条件下测量时，线圈温度应小于170°C。
 - (4) 当线圈实际工作电压超出曲线规定范围时，请联系美硕，并提供详细使用条件。
- (1) There should be no contact load applied when maximum continuous operation voltage is applied on coil.
 - (2) The operating voltage is connected with coil energized time and voltage. After energized, the operating voltage will increase.
 - (3) The maximum allowable coil temperature is 180°C. If or the coil temperature rise which is measured by resistance is average value, we recommend the coil temperature should be below 170°C under the different application ambient, different coil voltage and different load etc.
 - (4) If the actual operating coil voltage is out of the specified range, please contact Meishuo for further details.

2. 允许最大负载范围(23°C)
Load Limit Curve

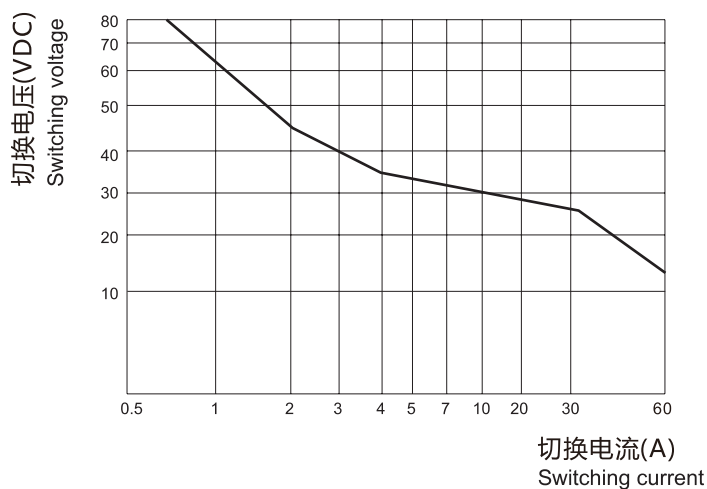

说明：

- (1) 本图以常开触点为例，本图电流为阻性。
 - (2) 产品按触点参数表进行负载与耐久性试验，当实际使用的负载电压、电流、动作频率、环境温度任一项与触点参数表不同时，请重新进行确认实验。
- (1) This chart takes NO contact, resistive load as example.
 - (2) The load and electrical endurance tests are made according to "CONTACT DATA" parameters' table. If actual load voltage, current, or operate frequency is different from "CONTACT DATA" table, please arrange corresponding tests for confirmation.

3. 电耐久试验环境温度曲线
Environmental Temperature Curve Of Electric Endurance Test

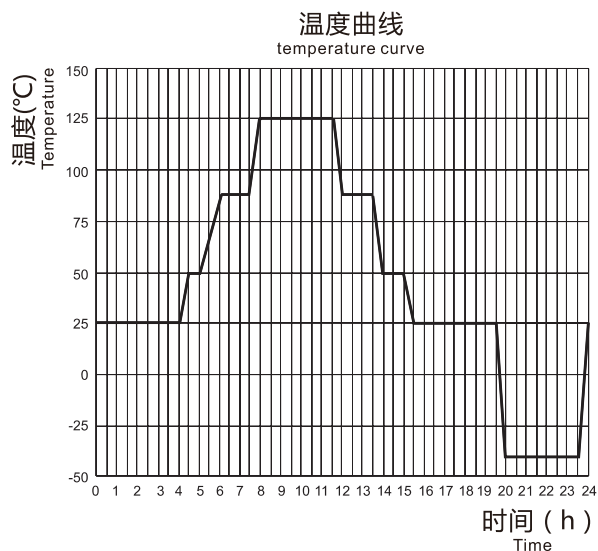

说明：

- (1) 最低温度为-40°C。
 - (2) 最高温度为125°C。
- (1) The minimum temperature is -40°C.
 - (2) The maximum temperature is 125°C.

声明:

本产品规格书仅供客户使用时参考, 若有更改, 恕不另行通知。

对美硕而言, 不可能评定继电器在每个具体应用领域的所有性能参数要求, 因而客户应该根据具体的使用条件选择与之相匹配的产品, 若有疑问, 请与美硕联系获取更多的技术支持。但产品选型责任仅由客户负责。

浙江美硕电气科技有限公司版权所有, 本公司保留所有权利

This product specification for client's reference, if any change without notice.

For Meishuo, can not require evaluation of relays in each specific application of all the performance parameters, so customers should be selected according to the matching conditions for the use of specific products, if you have any questions, please contact us and get more technical support. However, product selection responsibility only by the customer.

All rights reserved, Zhejiang Meishuo Electric Technology Co., Ltd , the company reserves all rights.