

**特性 FEATURES**

- 70A 触点切换能力
  - 工作温度高达 125℃
  - 一组常开触点形式
  - 防尘罩和塑封型可供选择
  - 可带瞬态抑制电阻
  - 外形尺寸: 26 × 26 × 25mm
- 
- 70A switching capability
  - Ambient temp. can up to 125℃
  - 1 form A contact arrangement
  - Dust protected type and sealed type available
  - With transient suppression resistor
  - Outline dimensions: 26 × 26 × 25mm

**触点参数 CONTACT PARAMETERS**

触点形式	Contact Arrangement	1A
触点材料	Contact Material	银合金 Silver Alloy
接触压降 (初始)	Voltage Drop(Initial)	典型值 Typ. 20mV, 最大值 Max. 300mV (at 10A)
最大连续电流	Max. Continuous Current	70A(23℃), 50A(125℃)
最大切换电压	Max. Switching Voltage	50VDC
电气寿命	Electrical Life	1 × 10 <sup>6</sup> 次 OPS
机械寿命	Mechanical Life	1 × 10 <sup>6</sup> 次 OPS

**性能参数 FUNCTION PARAMETERS**

绝缘电阻	Insulation Resistance	500MΩ (500VDC)
介质耐压	Dielectric Strength	触点与线圈间 Between Coil & Contacts: 500VAC 1min
		断开触点间 Between Open Contacts: 500VAC 1min
动作时间	Operate Time	≤10ms
释放时间	Release Time	≤6ms
环境温度	Ambient Temperature	-40℃ ~+125℃
振动	Vibration	10Hz~500Hz, 49m/s <sup>2</sup> (5G)
冲击	Shock	294m/s <sup>2</sup> (30G)
引出端方式	Terminal Form	快速接式引出端 QC
封装形式	Construction	防尘罩型 Dust Protected, 塑封型 Sealed
重量	Unit Weight	约 Approx. : 42g
机械性能	Mechanical Data	外壳保持力: (拉和压) 200N Cover Retention: (Pull & Push) 200N
		引出脚保持力: (拉和压) 100N Terminal Retention: (Pull & Push) 100N
		引出脚抗弯曲力: (各方向) 10N Terminal Resistance To Bending: (Front & Side) 10N

## 线圈规格表 COIL DATA(23℃)

额定电压 Rated Voltage VDC	动作电压 Operate Voltage VDC	释放电压 Release Voltage VDC	线圈电阻 Coil Resistance $\Omega \pm 10\%$	线圈功率 Coil Power W	并联电阻 Parallel Resistance $\Omega \pm 10\%$	等效电阻 Equivalent Resistance $\Omega \pm 10\%$	允许最大线圈电压 <sup>(1)</sup> Max Allowable Overdrive Voltage VDC	
							20℃	85℃
6	≤3.9	≥0.6	22.5	1.6	-	-	10	9
6	≤3.9	≥0.6	22.5	1.8	180	20	9	9
12	≤7.8	≥1.2	90	1.6	-	-	21	18
12	≤7.8	≥1.2	90	1.8	680	79.5	18	18
24	≤15.6	≥2.4	360	1.6	-	-	43	34
24	≤15.6	≥2.4	360	1.8	2700	317.6	36	34

注意：(1) 触点无负载电流，线圈电阻为最小值情况下，继电器线圈允许施加的最大连续工作电压。  
Note: (1) Max. Allowable overdrive voltage is stated with no load applied minimum coil resistance.

## 负载参数 LOAD DATA

负载电压 Load Voltage	负载类型 Load Type		触点负载电流 Load Current A	通断比 On/Off Ratio S		电耐久性 (次) Electrical Endurance OPS	试验环境温度 Ambient Temp.
				接通 On	断开 Off		
14VDC	阻性 Resistive	接通 Make	70	2	2	$1 \times 10^5$	At 23℃
		断开 Break	70				
	感性 Flasher	接通 Make	150	2	4		详见电耐久性 实验环境温度曲线 See Ambient Temp. Curve
		断开 Break	50				
	灯 Lamp	接通 Make	200	0.5	10		
		断开 Break	40				
27VDC	阻性 Resistive	接通 Make	40	2	2	At 23℃	
		断开 Break	40				

## 订货标记示例 ORDERING INFORMATION

			MAB	-S	-1	12	-A	-1	Y	R
产品型号	Model:	MAB								
产品结构	Structure:	无 Nil: 防尘罩型 Dust Protected S: 塑封型 Sealed								
触点组数	Contact Group:	1: 1 组 1 Group 06: 6VDC								
线圈电压	Coil Voltage:	12: 12VDC 24: 24VDC								
触点形式	Contact Form:	A: 常开 NO 1: 光背快连接引出端 Without Bracket & QC Terminal 2: PCB 引出端 PCB Terminal 3: 铁背快连接引出端 Metal Bracket & QC Terminal 4: 塑背快连接引出端 Plastic Bracket & QC Terminal								
结构形式	Version:									
引出脚形式	Terminal:	无 Nil: QC 引出脚带闭锁孔 QC Terminal with hole Y: QC 引出脚不带闭锁孔 QC Terminal without hole 无 Nil: 不带瞬态抑制电阻 Without Resistor R: 并联电阻 With Resistor								
线圈并联元件	Parallel Coil Components:	D1: 并联二极管 (阳极接 #86) With Parallel Diode (Anode on 86) D2: 并联二极管 (阳极接 #85) With Parallel Diode (Anode on 85)								

外形尺寸、接线图、安装孔尺寸 OUTLINE DIMENSIONS, WIRING DIAGRAM AND PCB LAYOUT (单位 Unit: mm)

外形尺寸 Outline Dimensions

MAB-□-1□□-A-1-□

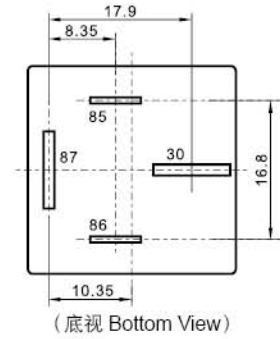
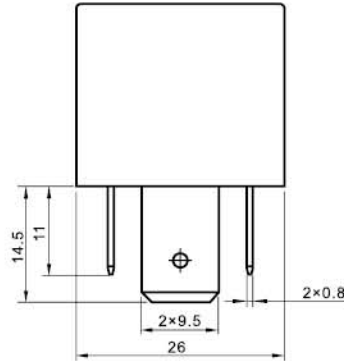
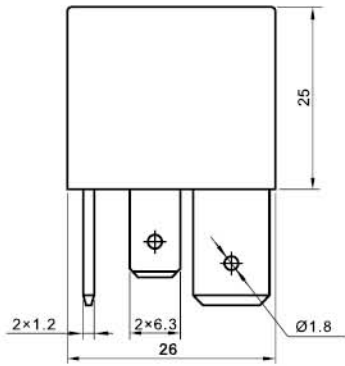

MAB-□-1□□-A-1Y-□

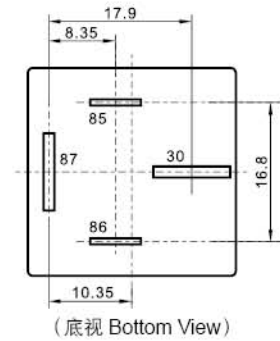
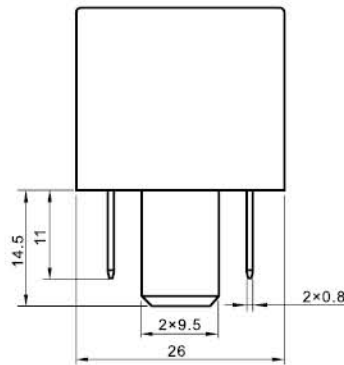
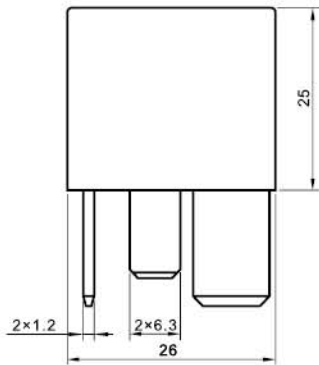

MAB-□-1□□-A-2-□

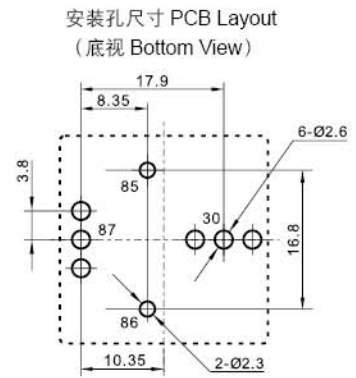
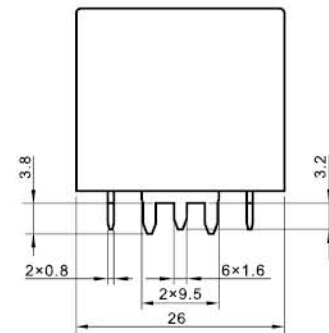
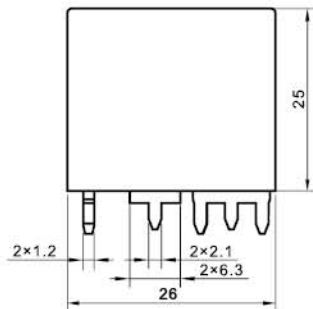

外形尺寸、接线图、安装孔尺寸 OUTLINE DIMENSIONS, WIRING DIAGRAM AND PCB LAYOUT (单位 Unit: mm)

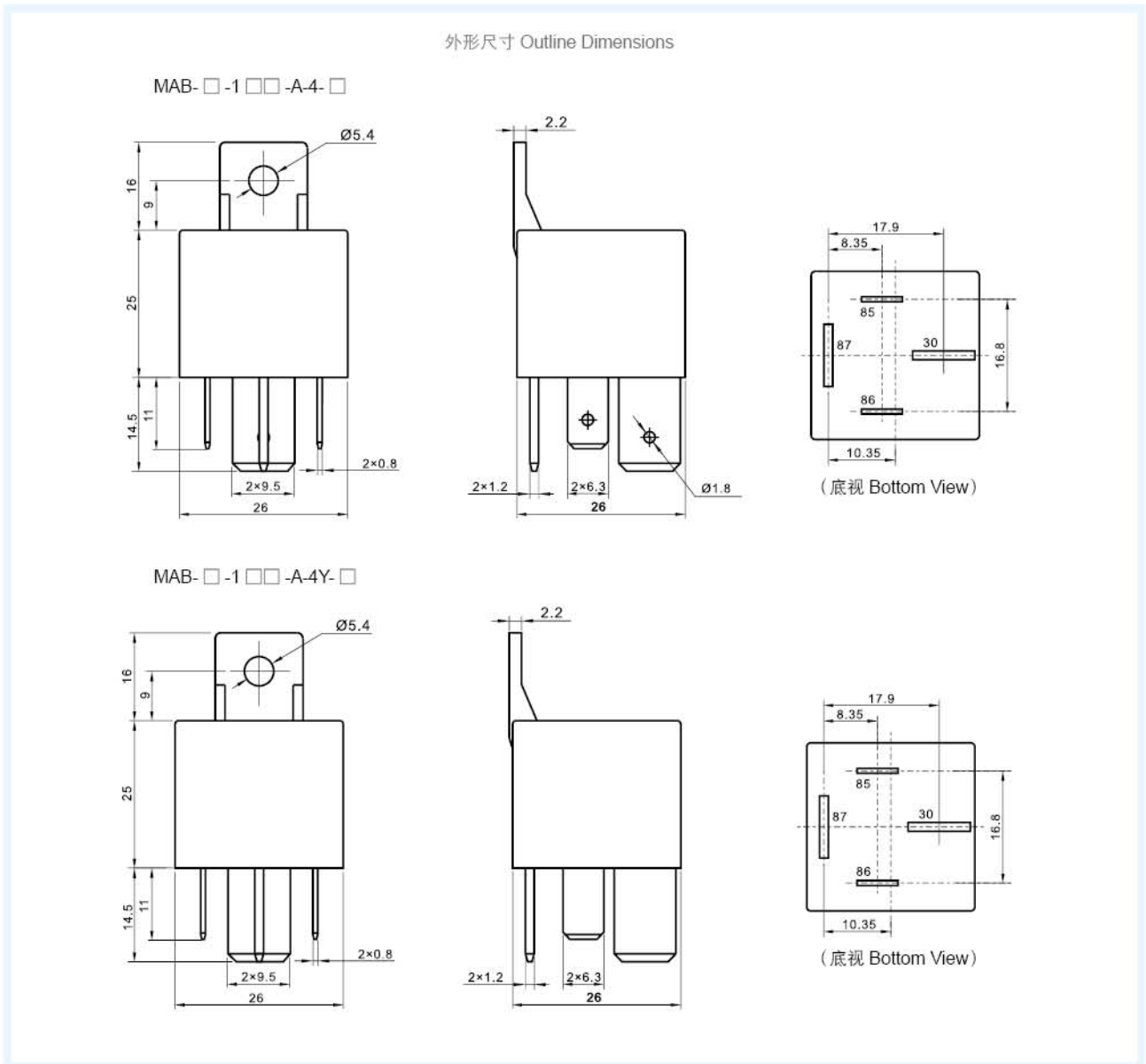

备注:

(1) 产品部分外形尺寸未注尺寸公差, 当外形尺寸  $\leq 1\text{mm}$ , 公差为  $\pm 0.2\text{mm}$ ; 当外形尺寸在  $1\sim 5\text{mm}$  之间时, 公差为  $\pm 0.3\text{mm}$ ; 当外形尺寸  $> 5\text{mm}$  时, 公差为  $\pm 0.4\text{mm}$ ;

REMARK:

(1) In case of no tolerance shown in outline dimension: outline dimension  $\leq 1\text{mm}$ , tolerance should be  $\pm 0.2\text{mm}$ ; outline dimension  $> 1\text{mm}$  and  $\leq 5\text{mm}$ , tolerance should be  $\pm 0.3\text{mm}$ ; outline dimension  $> 5\text{mm}$ , tolerance should be  $\pm 0.4\text{mm}$ ;

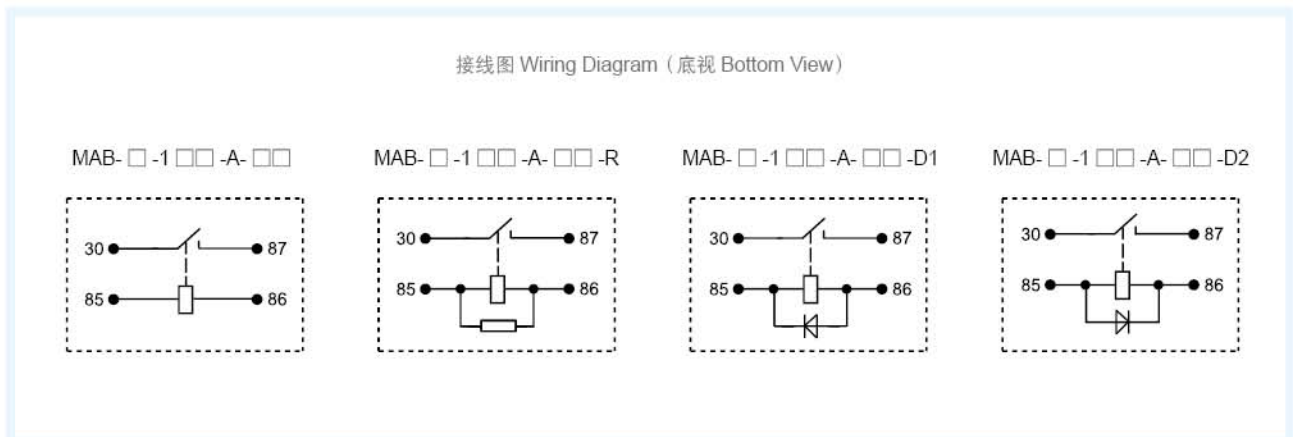

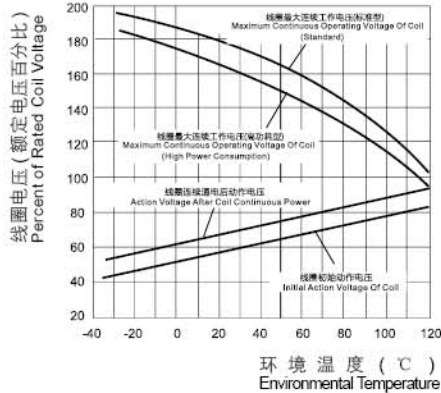
**性能曲线图 PERFORMANCE CURVE**
**1. 线圈连续通电电压范围**  
Coil Continuous Voltage Range

说明:

- (1) 动作电压与线圈预通电电压有关, 预通电后检查动作电压, 其值会变大
- (2) 线圈最大允许温度为 180℃, 考虑到电阻法所测量的线圈温升是平均值, 推荐在不同使用环境、不同线圈电压、不同负载条件下测量时, 线圈温度应小于 170℃。
- (3) 当线圈实际工作电压超出曲线规定范围时, 请联系美硕并提供相应详细使用条件。

- (1) The operating voltage is connected with coil pre-energized time and voltage. After pre-energized, the operating voltage will increase.
- (2) The maximum allowable coil temperature is 180℃. For the coil temperature rise which is measured by resistance is average value, we recommend the coil temperature should be below 170℃ under the different application ambient, different coil voltage and different load etc.
- (3) If the actual operating coil voltage is out of the specified range please contact meishuo for further details.

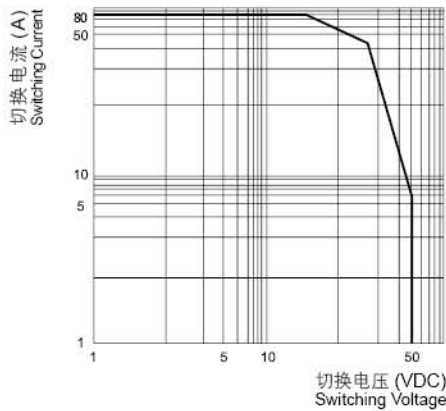
**2. 允许最大负载范围**  
Maximum Load Range

说明:

产品按接触点参数表进行负载与耐久性试验, 当实际使用的负载电压、电流、动作频率任一项与触点参数表不同时, 请重新进行确认试验。

The load and electrical endurance tests are made according to "CONTACT DATA" parameters' table. If actual load voltage, current, or operate frequency is different from "CONTACT DATA" table, please arrange corresponding tests for confirmation.

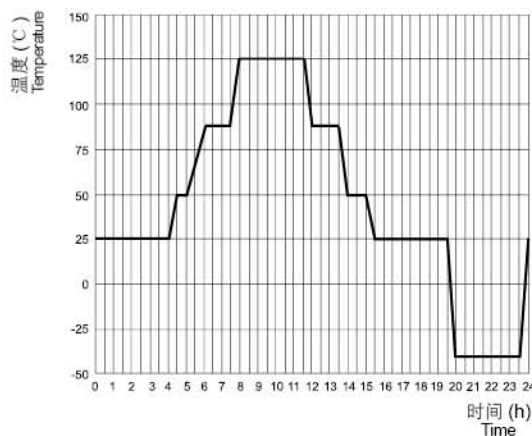
**3. 电耐久试验环境温度曲线**  
Ambient Temperature Curve of the Electrical Endurance Test

说明:

- (1) 最低温度为 -40℃
- (2) 最高温度为 125℃

- (1) The minimum temperature is -40℃.
- (2) The maximum temperature is 125℃.

**声明 STATEMENT:**

本产品规格书仅供客户使用时参考, 若有更改, 恕不另行通知。

客户应根据具体的使用条件选择与之相匹配的产品。如有疑问, 请与美硕联系获取更多的技术支持, 但产品选型责任由客户承担。

This product specification is for reference only to customers, subject to change without notice.

The customer should select the matching product according to the use condition. Any questions, please feel free contact us to get more technical support. However, product selection responsibility only by the customer.