

Bullbar Installation Guide

**ENSURE PAGE SCALING IS TURNED TO
NONE OR OFF WHEN PRINTING**



Part Number: BU21-3547, BU21-3718, BU21-3719

Isuzu D-Max Early 2017 on Facelift Models



This Bullbar will take approximately 3.5 hours to install

Tools required are

- Spanners and socket set.
- Pneumatic hacksaw
- Screwdrivers
- Pliers and side cutters
- Torx-bit Screwdriver Set

Dobinsons BULLBARS should be installed by a qualified installer and it is the installer responsibility to ensure correct fitment.

Fully read and understand the instructions before beginning the installation

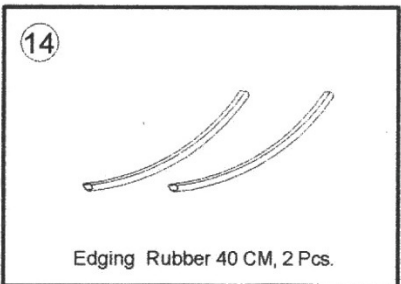
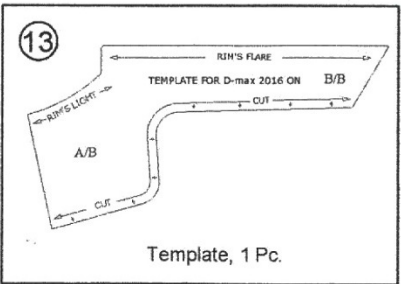
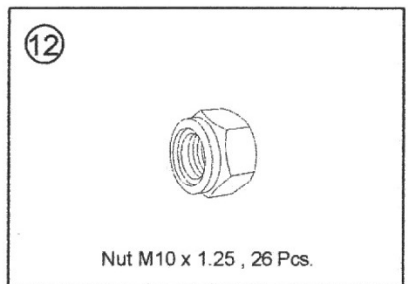
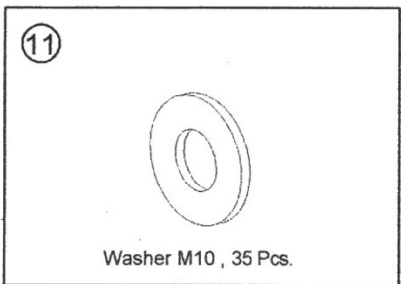
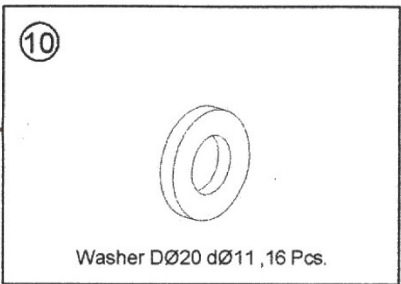
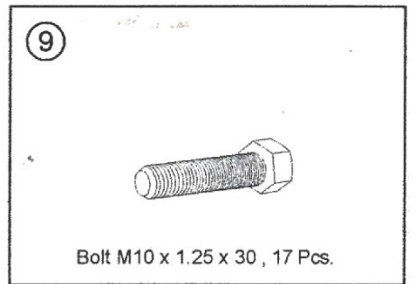
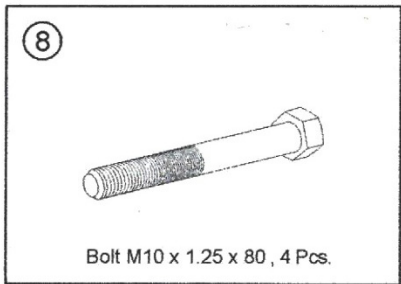
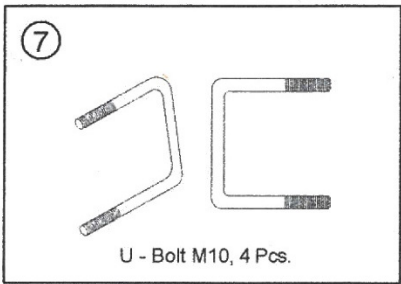
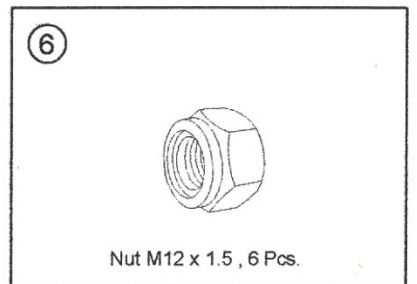
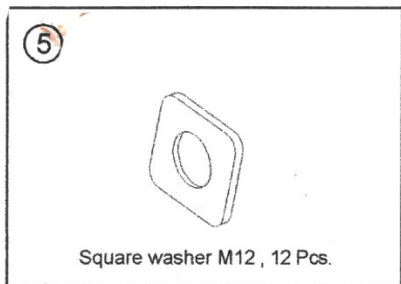
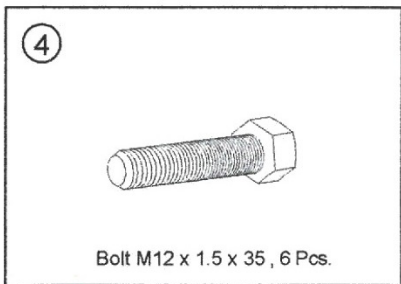
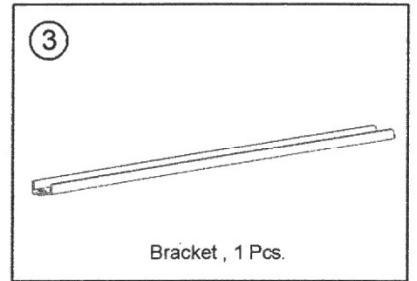
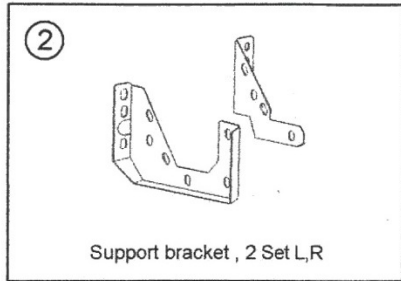
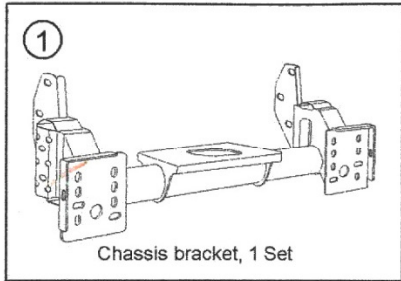

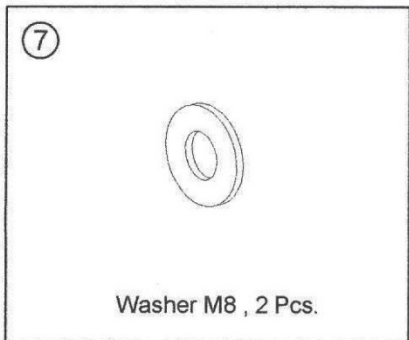
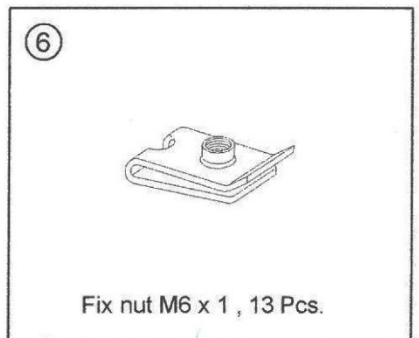
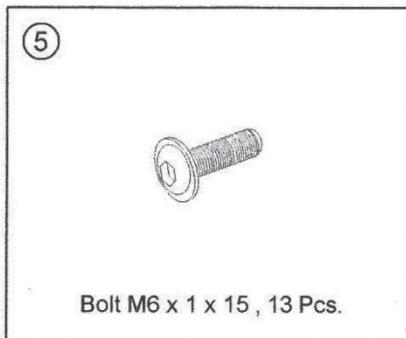
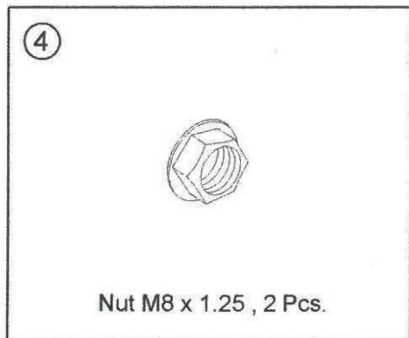
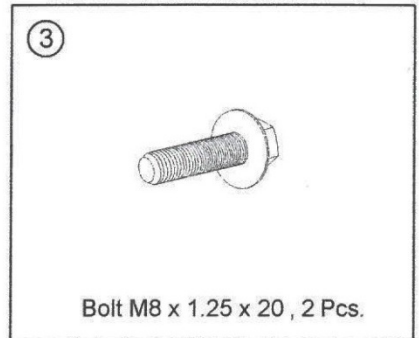
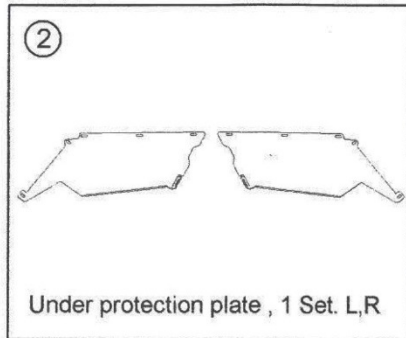
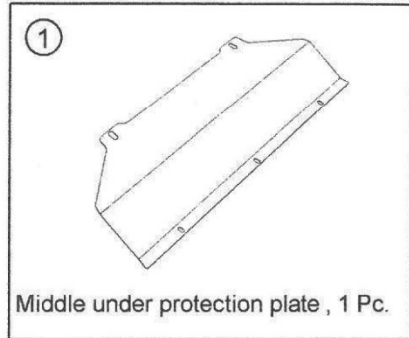

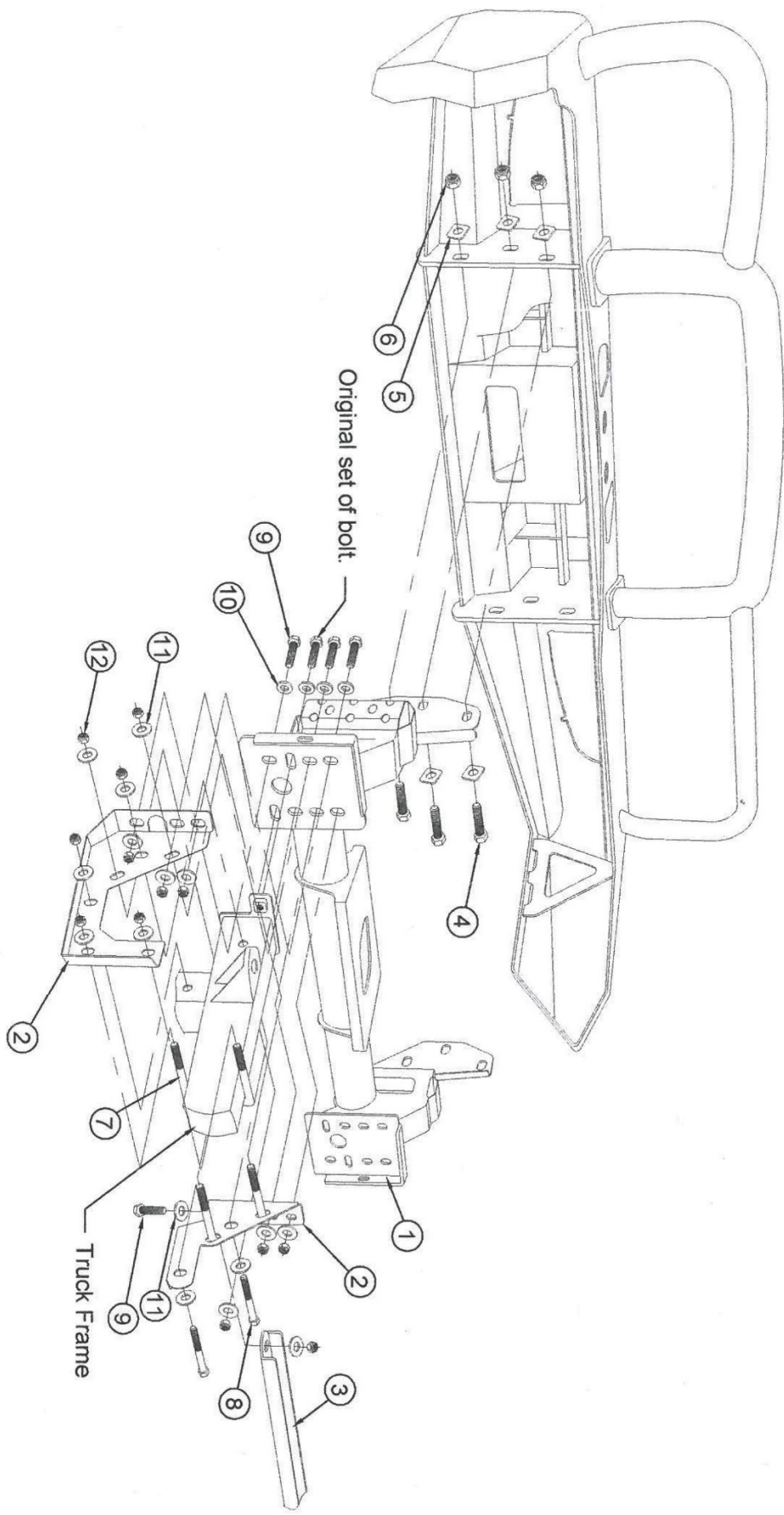

Fitting Guide

1. Remove the number plate.
2. Remove the screws and bolts from the top of the grill.
3. Reach down in behind the bottom of the grill and carefully unclip the grill from the top of the bumper (red arrows shown below), then remove the grill. Remove the clips from the top of the bumper (blue arrows).

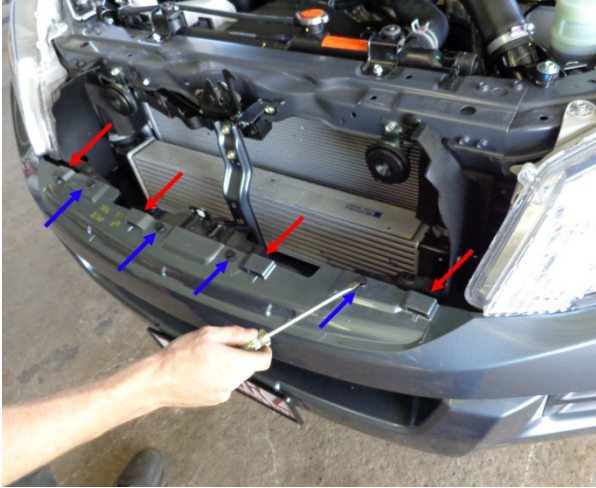

4. Remove the clips along the inside edges of the wheel arches on both sides.



5. Remove all the fasteners securing the bottom edge of the bumper to the vehicle.
6. Starting from each edge of the top of the bumper, gently unclip the bumper.



7. Carefully remove the bumper from the vehicle, and remove the bumper reinforcement bar.



8. Remove the lower bash plate and put aside for re-fitment later.
9. Remove the inner and outer "L" shaped bumper support brackets, 4 in total.
10. Loosely install the bullbar support brackets (item 2) to either side of the chassis on both sides as per the diagram on page 3 and the under protection cross beam (item 3). Ensure that the U-bolts do not pass over any wiring.
Note: Ensure clearance to the radiator supports and these brackets, grind a small amount away if necessary.

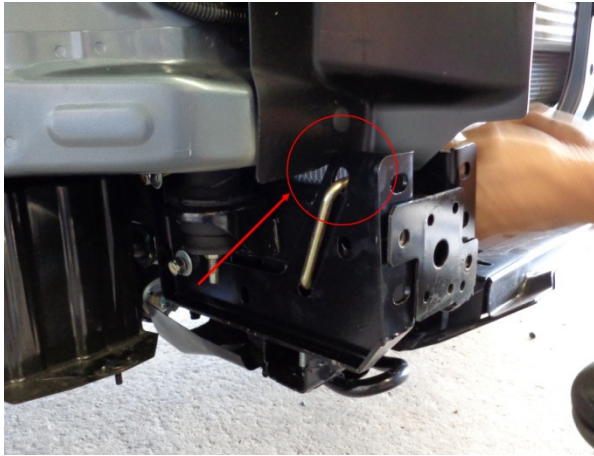

11. Fit the bullbar mounting bracket.
12. Ensure the bullbar mounting bracket is central to the vehicle and as low as possible and tighten all fasteners.



13. Ensure that page scaling was turned off when printing this guide, cut out both parts of the template at the end of this guide and measure the scale line. It should be within 1 or 2mm.
14. Masking tape the bumper ready to mark for cutting.
15. Align the alignment marks directly on top of each other and tape together. Align the template on the vehicle bumper as per instructions on the template and mark the cut lines. The template can then be flipped upside down to mark the other side.



16. The line can then be marked across the bumper just under the bumper recess.

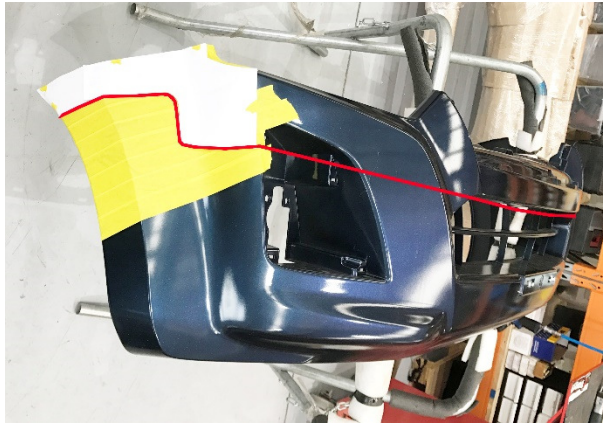

17. Using a pneumatic hacksaw carefully cut along the marked line, and install the pinch weld rubber edging.



18. Re-install both of the small bumper to the vehicle ensuring they are clipped in properly at the sides.
19. Re-install the grill.



20. Carefully un-wrap the bulbar taking care not to scratch it especially on the top loops. Reinstall the number plate to the bullbar as it is easier now. If installing driving lights to the bullbar it is easiest to install now.
21. If not installing a winch skip to step 29.
22. See the Installation section of your Dobinsons 4x4 Winch manual for specific detailed fitting instructions. For a brief overview see the following steps.
23. Test fit your winch to the mounting bracket and do up loosely with the clutch handle on the left hand side of the vehicle.
24. This may require the clutch handle and gear-box housing to be rotated forward one or 2 bolt holes to allow easy access through the bulbar holes. See instructions in winch user manual.
25. Determine where the winch control box will be located and mount the control box. See instructions in winch user manual for control box mounting options. If mounting to the top of the bullbar using the supplied bracket, check clearance of control box to grill and also check where the wires will route as if the wires are passing through the holes in the top of the bullbar the control box may not be able to be wired until the bullbar has been fitted as below.
26. Wire the winch up as per the winch instruction manual and bolt the winch to the mounting bracket, ensure the mounting bolts

are not too long and tighten correctly. Route the wires and connect to battery and also route the breather hose.

27. Unwind some cable from the winch, and pass the cable through the fairlead hole in the bullbar and through the roller fairlead. This may require removing a circlip from the fairlead and re installing once the cable is passed through.
28. Install the roller fairlead into the bulbar.
29. Check the poly bulbar over riders, fog light and top loop bolts are tight (Do not over tighten the stainless steel loop mounting bolts. Do not over tighten the poly bullbar over riders as they will pull the over riders out of shape).
30. Wire up the lights. Using a multimeter or test light first locate the earth wire, parker positive and indicator positive wires from the wiring on the back of the original vehicle lights on each side.
31. Unclip the wiring from the indicator/parker lights. Check that the wiring will be long enough to reach the new bullbar indicator/parker lights and extend if required. Using the diagram at the end of this manual, join the corresponding wires to original vehicle wires located in the previous step. The wires can be joined by either using good quality snap lock crimp connectors or by soldering. Ensure the connection is secure and is sufficiently insulated.

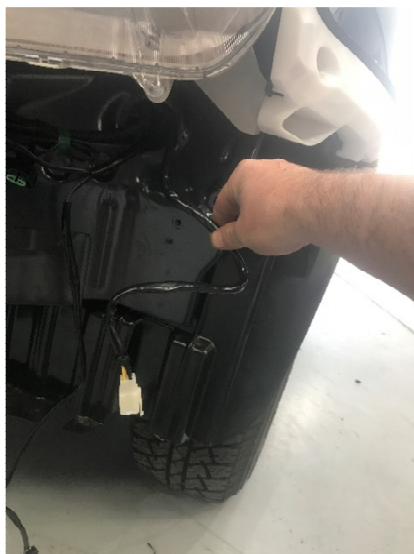

32. **Warning:** If fitting a fog light, the original fog light wiring harness cannot be used as it will



not suit the new 55 watt lights. The existing harness can be used to switch the relay for the newly supplied harness but cannot be used directly for the fog lights. If the vehicle is not fitted with OEM fog lights the wiring loom supplied can be used. Follow the wiring diagram at the end of this manual.

33. With help, fit the bullbar into position and install nuts and bolts supplied.
34. Align the bar, leaving a gap between the bullbar wing tip and the bumper of around 15mm.



35. Once you are happy with the alignment tighten the nuts and bolts on each side.
36. Once happy with the alignment of the bullbar drill 2 x 8mm pinning holes on each side of the bullbar drilling through both the mounting bracket mounting plate and bullbar mounting plate. Fix with 8mm bolts and nyloc nuts to keep the bullbar in its position. This may be easiest performed by drilling with a small bodied drill from the inside or a right angle drill chuck from the outside.

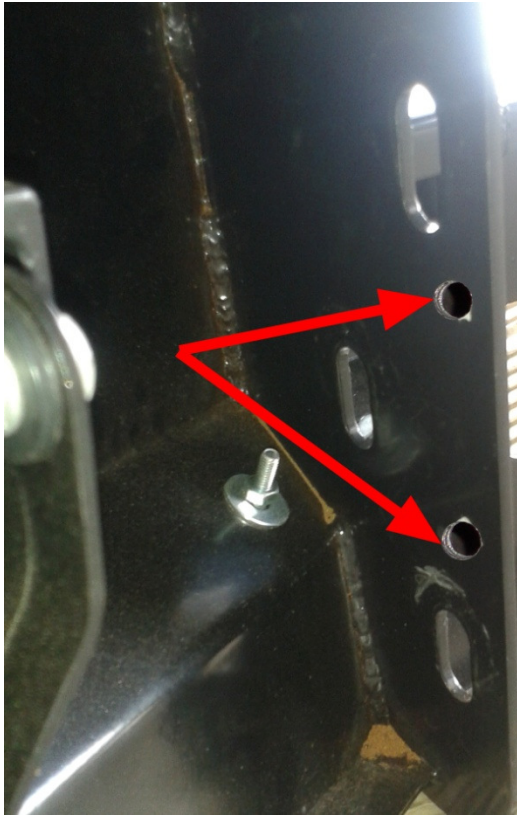

37. Plug the wires into the indicator, parker light plug and fog lights. Test all lights and adjust the position of the fog lights if required.
38. Fit the under bar protection kit now with the bolts supplied. Fit the centre piece first loosely fitting the front bolts. Then install the remaining 2 bolts and washers from the bracket fitting kit into through the rear of the plate into the cross bar fitted earlier. Only thread these bolts in a few turns. Then slide the original vehicle bash plate over the bolt heads and washers and install the rear original bolts.



39. Install the side plates and tighten all nuts and bolts in all under protection plates.
40. Check over all items removed during installation.
41. Trim the wheel arch splash guards level with the bottom of the under protection plates/vehicle body and secure.
42. **IMPORTANT NOTES:** It is important to inform the customer that headlight adjustment may also be required due to the change in ride height. It is also important to inform the customer that there will be a change in vehicle handling characteristics. It is also important to note that due to their nature fog lights are required to provide a yellow light to allow clear fog vision. For this reason Dobinsons bullbars utilise a Halogen bulb. Halogen bulbs generate a considerable amount of heat to achieve the yellow colour and this causes the air inside the fog light lens to expand and contract. For this reason the fog light assembly cannot be sealed and has a small breather on the back. In some cases this may cause condensation to form inside the

fog light. The customer may choose to seal the lens of the fog light but must not seal the rear breather.

FOLLOWS GUARD CONTOUR



100MM SCALE LINE

2017 DMAX

CUT

ALIGN WITH BUMPER TO PANEL EDGE

ALIGNMENT MARKS

CUT

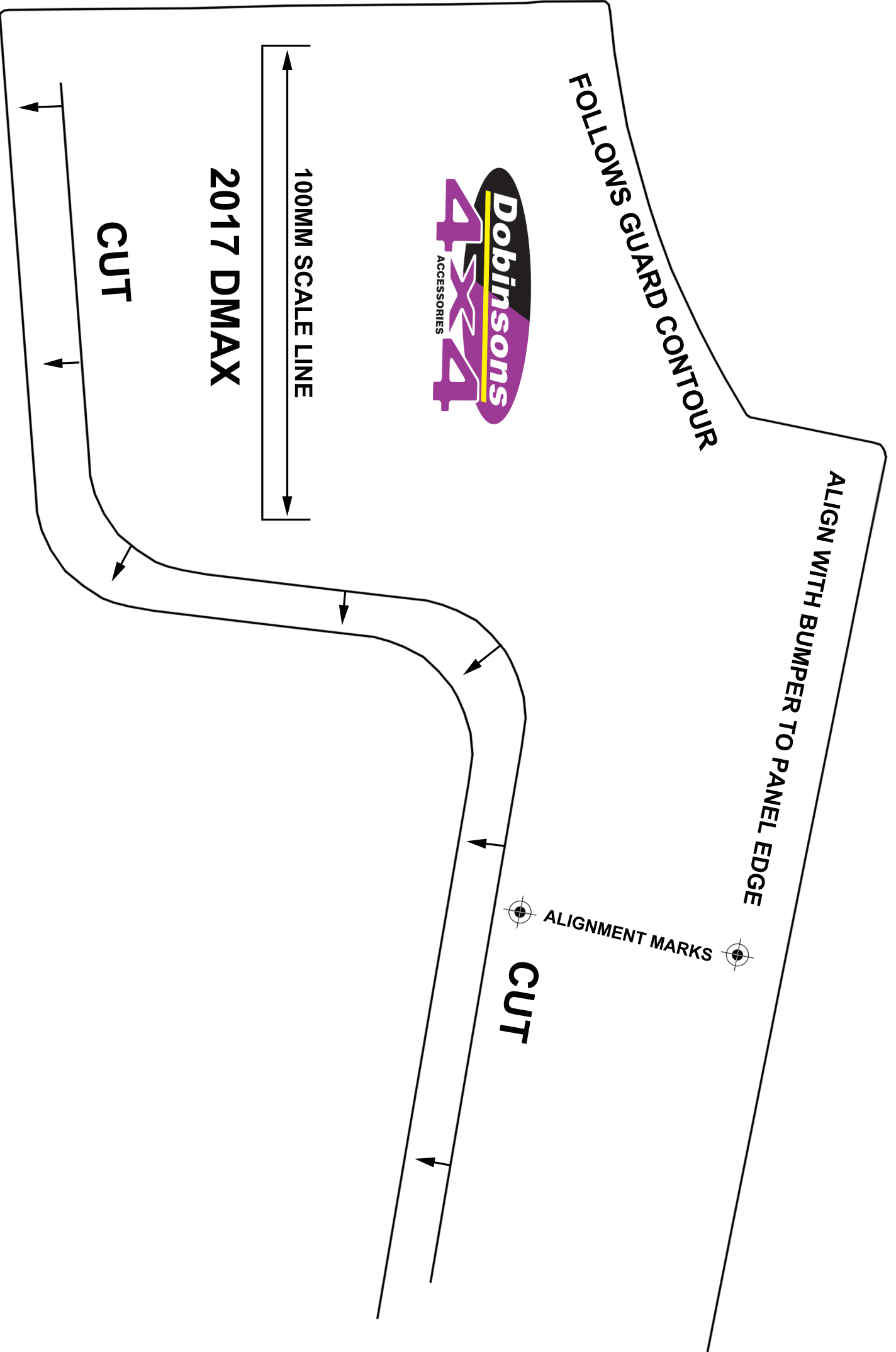

ALIGN WITH BUMPER TO PANEL EDGE

2017 DMAX

100MM SCALE LINE



CUT

**ALIGNS WITH BUMPER
WHEL ARCH EDGE**

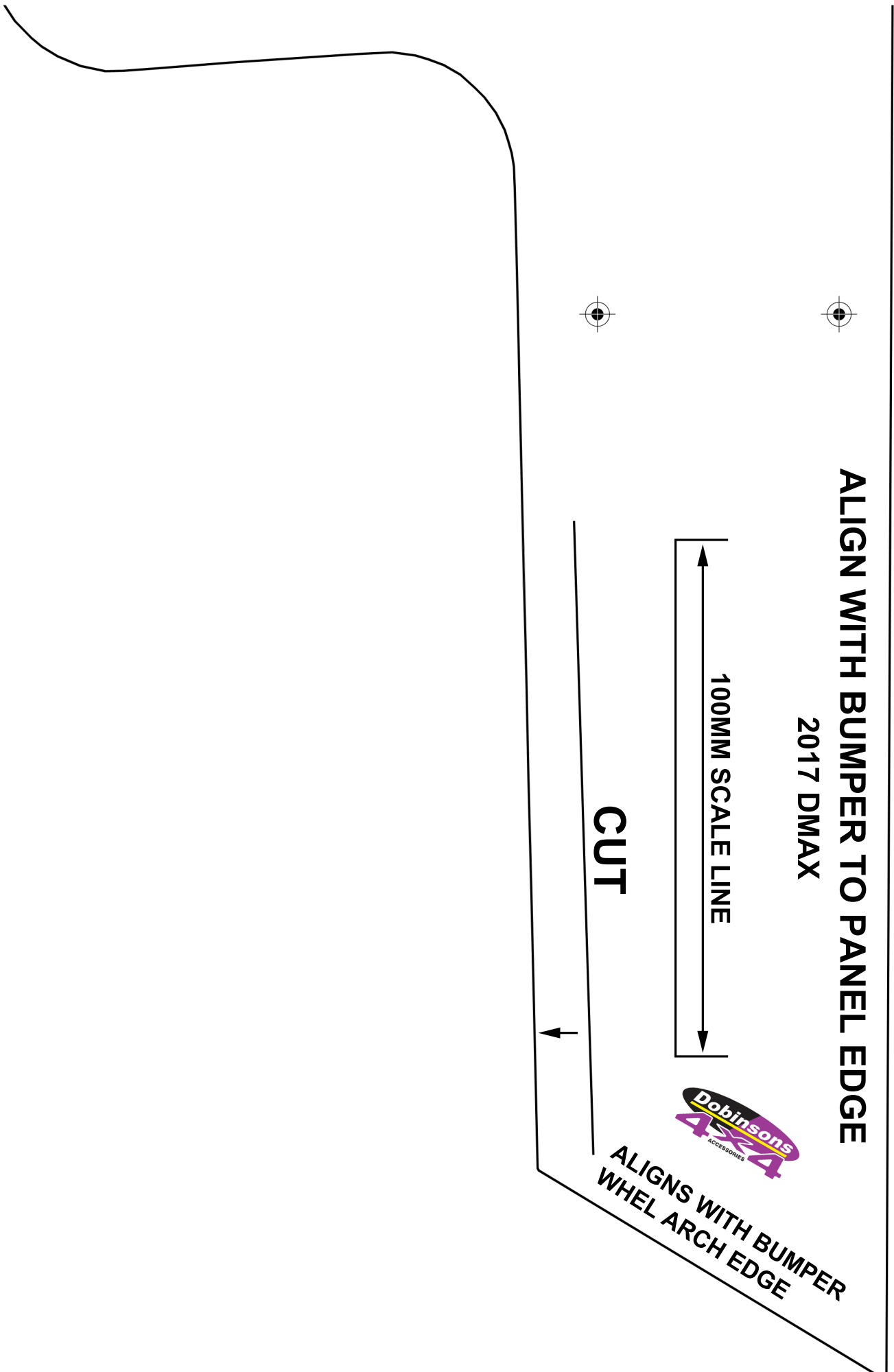

FOG LIGHT WIRING DIAGRAM

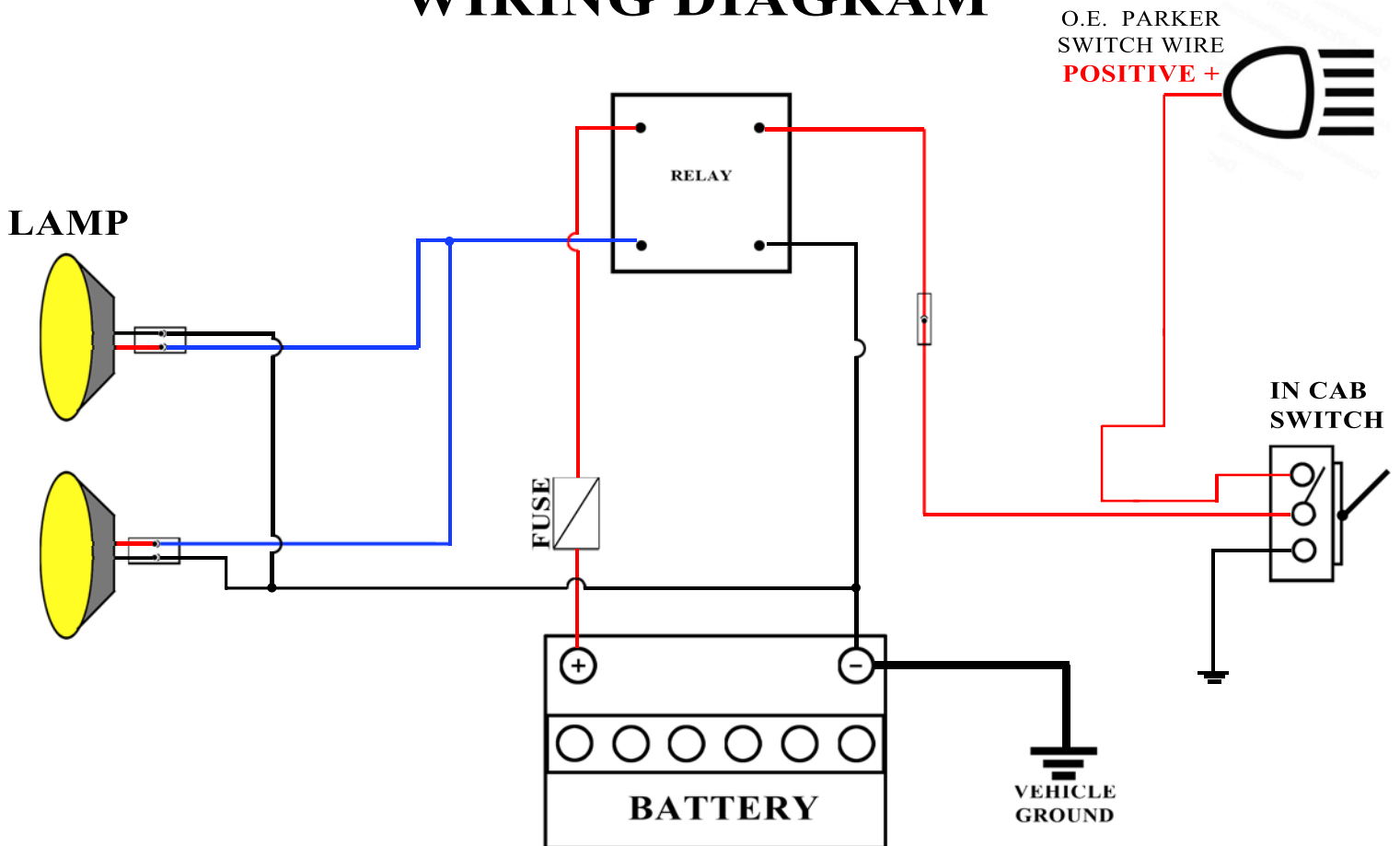

CHECK THE PARKER/INDICATOR WIRING LIGHT CONFIGURATION AND USE THE CORRECT WIRING DIAGRAM AS SEEN BELOW

TYPE 1 - YELLOW, BLACK WHITE FROM LIGHT AND CONNECTOR

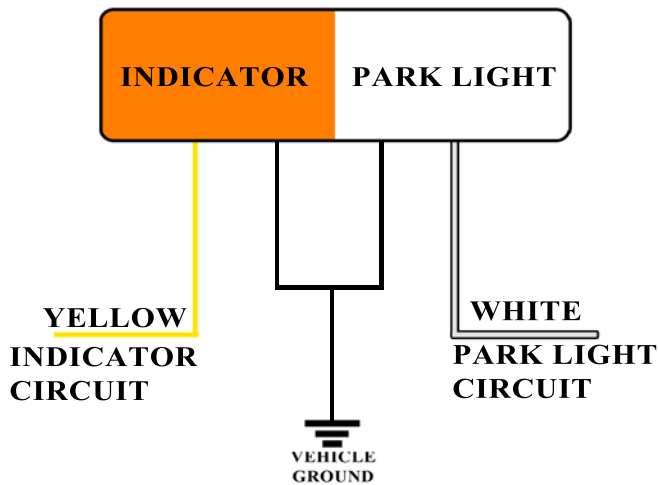

TYPE 2 - YELLOW, WHITE, BROWN FROM LIGHT BLACK, WHITE, RED FROM CONNECTOR

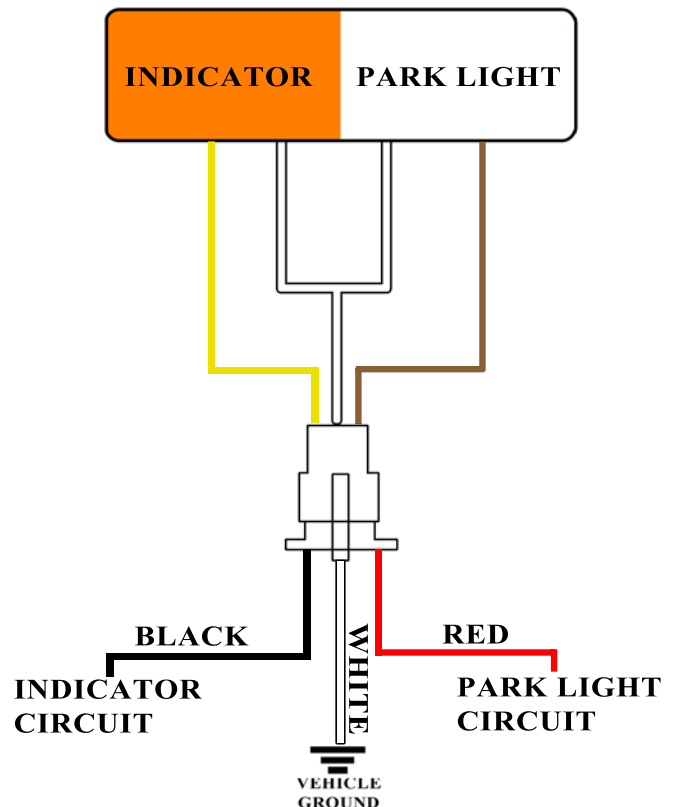

Customer Copy: Bullbar Care Instructions



To ensure the surface finish quality it is recommended that the bullbar be washed and cleaned regularly to prevent build up of dirt and contaminants which when exposed to the elements can degrade the surface finish. It is highly recommended to use a quality Carnauba wax on the bullbar powder-coat once a year to ensure a long lasting quality finish. It is also recommended that the mounting fasteners on the bullbar be checked after 1000km's. Winch servicing and care should also be carried out as per the winch instruction manual.

Stainless Loop Deluxe Bullbar Loop Care and Maintenance

(Customers with Stainless Loop Deluxe Models Only)

The top loops on your Dobinsons Stainless Loop Deluxe steel bullbar are manufactured from high quality 304 grade stainless steel. Once formed and welded it is highly polished to provide a high gloss finish. Whilst the material is a high quality stainless steel, like any other exterior polished surface, care and some maintenance is required to ensure the surface finish quality.

It is recommended that the stainless loops be kept as clean as possible and is thoroughly washed and dried regularly to prevent build up of dust and contaminants. This is especially important in coastal and high dust areas. The loops can simply be cleaned with most regular car cleaning items like a soft sponge, car wash and a chamois, avoid strong cleaning chemicals. Like many other highly polished exterior metals, over extended periods of time and heavy weathering can cause some staining of the surface may occur. If this occurs the surface can be simply polished using the following methods to remove the stains and restore the high gloss surface using simple tools and cheap readily available polishing items.

Tools Required:

- Electric buffer or Electric drill (an electric/cordless drill is generally more convenient).
- Polishing compound – This can be supplied by Dobinsons Spring and Suspension. Please contact head office on the details below for polish, as a specific type is used.
- Soft finishing type buffing wheel – The buffing wheel should be a soft, finishing type/Calico loose leaf style to allow the surface to be polished to a high gloss without further marking the surface. The 2 types of discs shown below are readily available from most hardware stores (Australian customers – Bunnings etc). The brand below is Josco, and if purchasing a twin pack ensure that only the finishing buff is used and not the cutting buff. **DO NOT USE METAL OR HARSH BUFFING PADS.**



Method

1. The stainless loops may be removed from the bullbar if this makes it easier to work on, however if using a cordless drill this is not a necessity. If removing the loops, do not over tighten the loop retaining bolts when re fitting.
2. Ensure the loops are first completely clean and dry.
3. Fit the polishing buff wheel to the drill or buffing tool –take note of the maximum wheel speed and rotation direction.
4. It is recommended to follow specific instructions on the packaging of the buffing wheel for best results. However if no instructions are provided the following guidelines can be used:
 - A). Carefully dress the buff wheel with the compound across the rotating wheel for a few seconds, taking care not to apply too much compound, it is better to apply a little compound more frequently than to overdress the buff.



- B). Gently buff the work area with the buffing wheel and with light pressure move back and forth across the job.



- C). After polishing use a soft, clean, dry rag to clean the surface and inspect in the light for an even finish.
- D). Once complete clean thoroughly again with a sponge and warm water.