

# WA45-513K 5 Degree Caster Plates Nissan Patrol GQ, GU Series with Coil Spring Suspension

For 5" (130mm) - 7" (170mm) Lifts

It is important to work on one radius arm at a time.

Firstly check the 4 plates. 3 Caster Plates will appear similarly shaped. One will appear different to the other 3. This odd plate must be installed to inner side nearest the enlarged diff casing as it has been shaped to allow clearance.

1) Remove both bolts from radius arm to diff mount. Then position caster plates with 1/2 cut washer facing inward, loosely install and lightly tighten new rear bolt and nut to hold both plates in place. See pictures below.

2) Raise front of caster plates so the 1/2 cut washer is butted up against bottom of diff mount brackets. See picture below

2a) Disconnect the battery before welding on vehicle. Use vice grips to clamp, then run a small tack weld along the front or top edge of the caster plates and diff bracket to firmly secure caster plates into position. Checking again that the 1/2 cut washer is butted firmly against diff bracket.

3) Using the front upper hole on the caster plates as a guide, drill into the diff mount.

3a) Use a 16.5mm drill bit, and a right angle drill attachment for best results.

4) Loosen rear radius arm bolt and remove front bolt on the other side of vehicle (the arm your not working on) to allow the diff to rotate and aid in positioning the caster plates.

4a) Return to caster plate assembly and install new front lower bolt, followed by front upper bolt including spacer tube between diff mounts. See pictures below.

5) Only tighten assembly after vehicle has been lowered to the ground.

6) Move to the other arm and repeat steps 2 - 4a. Step 4 will not have to be repeated as the diff should be in its correct position.

7) Wheel align vehicle, and check tension of all bolts after 500km.

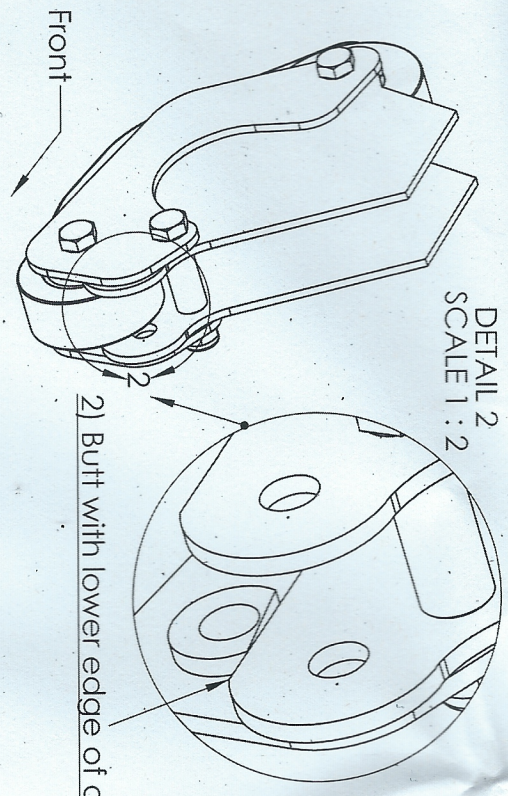

2) Butt with lower edge of diff bracket x2

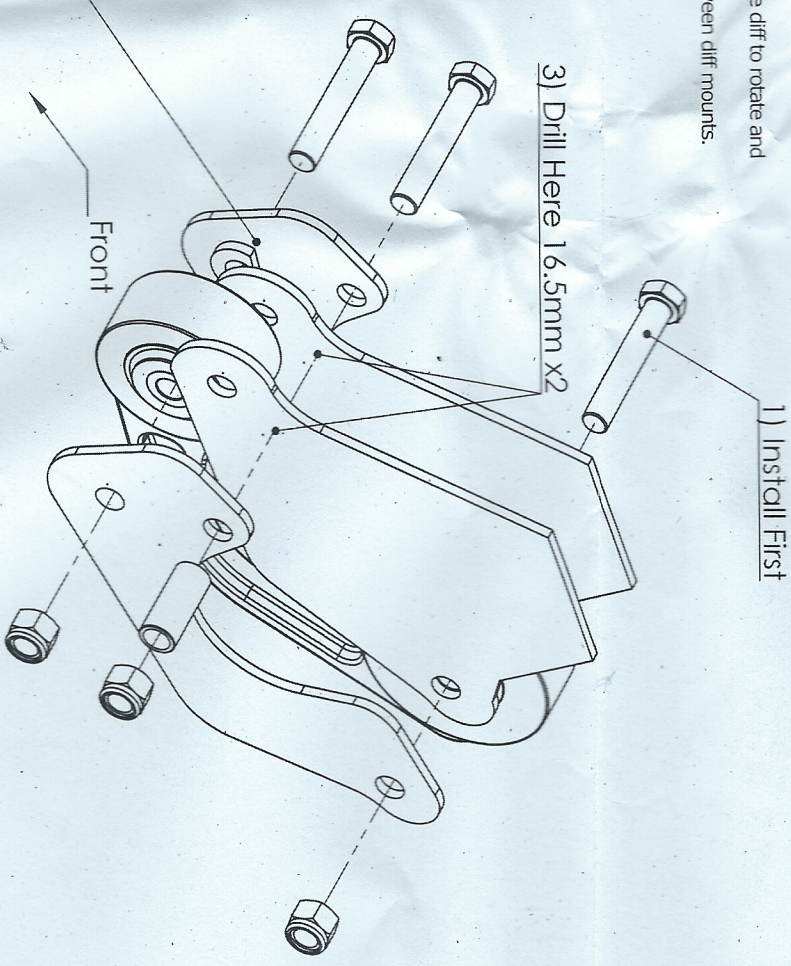

58 Hollingsworth Street North Rockhampton  
Queensland Australia  
+61 7 4927 7444  
admin@dobinsonsprings.com



Some image detail has been emmritted for clarity