

Installation Guide

UCA45-205k – Nissan Navara Upper Control Arms



Dobinsons adjustable upper control arms for the Nissan Navara D40/NP300 are manufactured from a drop forged high strength aluminum that incorporates adjustable bush ends and a high clearance design to allow proper alignment at larger vehicle lifts of around 55 – 90mm and to allow more droop travel for larger lifts.

1. If the vehicle already has the lift kit fitted, measure the centre of wheel hub to bottom of guard measurement to record the lift amount on the vehicle. Generally 515-525mm is a standard OEM vehicle measurement.
2. Raise the vehicle safely from the chassis and support the chassis with chassis stands.
3. Remove the wheels
4. Using a jack under the lower sway bar mount or control arm outer ball joint take some pressure of the suspension.
5. If changing the coil springs and shock absorbers disconnect the sway bar link and outer steering arm ball joint.
6. Remove the split pin and nut from the upper control arm (UCA), outer ball joint, leaving the nut on a few threads. Using a hammer hit the upper spindle housing with a firm hit to dislodge the UCA balljoint and remove the nut.
7. Carefully Lower the jack under the control arm and release the UCA balljoint from the spindle. Ensure the spindle and any lines and wires are not damaged
8. Remove the upper control arm inner retaining bolts. NOTE: on the right side it can be difficult to remove the rear bolt. In some cases you may need to do the following:
 - A). Mark the exact position of the steering arm spline alignment where it bolts to the top of the steering rack.
 - B). Remove the locking bolt and slide the spline off.
 - C). Carefully lever away the steering arm near the UCA upper rear bolt so that you can remove the bolt.
 - D). Re-align the spline on the steering arm to the steering rack and re-install the bolt and tighten.
 - E). when re-fitting the new arm the bolt can be installed from the opposite direction.



9. Remove the factory UCA.
10. Setup the Dobinsons UCA measurements
 - A). Loosen the 6mm thread clamping bolts and large locking nut
 - B). On both front and rear of the arm, unwind the bush eye end and the adjustment sleeve nut out most of the way and install some anti-seize or equivalent. NOTE: the adjustment sleeve has a LEFT HAND THREAD and will need to be rotated clockwise to be unscrewed
 - C). On both front and rear of the arm, Thread both the bush eye end and the adjustment sleeve into the UCA body as far as they will go until both threads are bottomed – do not force this tight, just until they stop. Then wind only the bush eye end out until it is aligned correctly – this is with the bush ears completely to the front and completely to the rear on the arms, they bush ears should not be in the centre of the arm.
 - D). With the arm on a flat surface, hold the bush eye ends down to keep the flat and in line with each other and on both front and rear of the arm, adjust the adjustment sleeve to the desired measurement. This is measured from the end of the main UCA body to the machined edge of the eye that the bush is pressed into. Generally this starting measurement is 31-32mm. Ensure the bush end does not rotate during this process.
 - E). Ensure both front and rear bushes are flat on the benched, aligned and orientated correctly and tighten the 6mm clamp bolts to clamp both threads tight and lock the locking nut
 - F). Double check the measurement hasn't changed

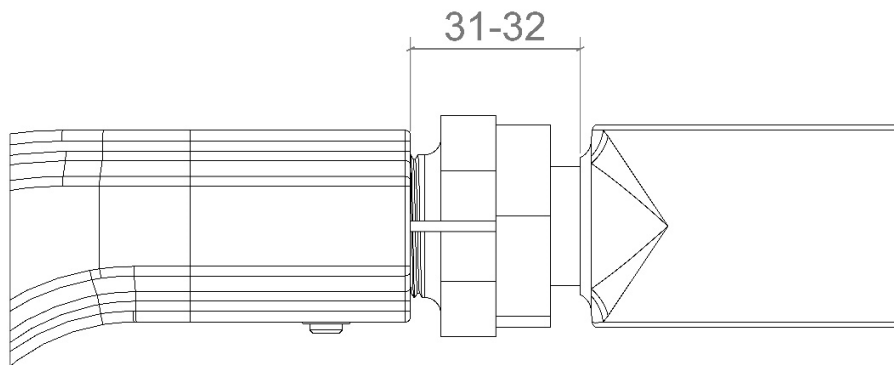

11. With the arms now set at the correct alignment they can be fitted to the vehicle, ensure they are fitted to the correct sides. **The inner arm bolts must first be tightened in the correct position.** Fit them to the spindle ball joint and then raise the wheel hub so that the centre of hub to bottom of guard measures around 550mm. This is approximately the centre of the wheel travel. This is critical to ensure the rubber bushes are tightened in the centre of the travel to allow even rotation in both directions to prevent over rotation of the bush which will instantly damage the bush. The suspension can be re-fitted to the vehicle however first it is important to read the information on following 2 pages.
12. **IMPORTANT:** After fitting and alignment, drive vehicle for a few klms to work the suspension through its travel and then recheck the lock nut and lock bolt tension.

Important Installation and Alignment details – Please also give instructions to aligner

As the Nissan Navara has a very tight radius between the UCA and the coil tower it is critical to ensure that the UCA does not touch the coil tower at full droop. Generally the area that the coil tower will contact the UCA is toward the rear of the tower where the UCA ball joint is. To ensure this is correct the desired final wheel alignment and tire to guard clearance will need to be considered together to ensure the UCA does not contact the coil tower. This must be checked after the final wheel alignment is completed.

The vehicle final wheel alignment figures will need to be considered. If more negative camber and less castor angle is desired, then the upper arm may need to be shortened or wound forward slightly to achieve this, reducing the clearance between the UCA ball joint and coil tower.

Although the OEM alignment specifications from Nissan state a very large tolerance on the Castor, Camber and Toe-In figures it is the aligners responsibility to ensure the accuracy and outcome of the alignment figures to achieve good drivability, stability and tyre wear or to meet the customers requirements.

As a guide only where the alignment figures are absent Dobinsons suggest the following as a guide only-

Castor – Castor figures generally are higher than the manufactures specifications for improved stability on lifted vehicles. In most cases the UCA's achieve between 2°30' to 4°40' with around half a degree more castor on the left hand side for RHD vehicles and vice versa for LHD vehicles to account for road camber. Tire clearance to rear guard may also be taken into account for larger tires.

Camber - Camber figures where possible should be set to between -0.5° and 0°. Positive camber should be avoided where possible.

TOTAL Toe In – TOTAL Toe in figures should generally be set to be 0.5 and 1.5mm total toe in.

DISCLAIMER: The above figures are a guide only. Dobinsons take no responsibility for any wheel alignment, tyre wear, handling or stability issues.

NOTE: It is not recommended to have more than half a rotation difference between the front and rear adjustment nuts. Exceeding this may prematurely damage the bushes and UCA's and will not be covered under warranty.

Full Droop – the full droop measurements will need to be considered. Depending on the size of the lift fitted to the vehicle, the vehicle must maintain at least 45mm of droop travel from right height.

Fitting the UCA's set with an end gap of 31-32mm will allow the UCA's to droop to around a measurement of 640-650mm centre of wheel hub to the underside of the wheel arch measuring directly vertical upward, without the UCA contacting the tower. This will generally be OK for all vehicles with roughly 50 – 75mm lifts. Shock lengths should be limited so that the vehicle tops out on the shock first at 645mm or less (see diagram below measurement "X") **before** the UCA can touch on the coil tower. As an approximate guide shock lengths should be limited to around 418-422mm (total including the external spacer), this should be confirmed at full droop with the coil and shock absorber fitted as variances can occur between upper mounting bushes, washers, strut top caps and coil towers.

If the UCA is touching the tower or for customer looking for larger lifts and for longer droop measurements the coil tower may need to be ground down just slightly in the section at the rear to allow more droop clearance at the UCA Ball Joint. This MAY require a depth of around 3-6mm or so to be removed using a flap disk, grinding to smooth the radius only at the section where it touches. This generally will allow full droop measurements of around 650-655mm using a shock length of around 420mm. For extra long travel requirements offset lower control arm bushes are required, diff drop, extended sway bar links with angle ball joints to prevent bind, a shock absorber that is around 425mm long.

DISCLAIMER: *Dobinsons Spring and Suspension take no responsibility for any damage or issues incurred from modifications undertaken to the vehicle coil tower.*

