

Bullbar Installation Guide

Part Number: BU59-3661& BU59-3511

Fits:



Toyota Prado 120 Series / Lexus GX470



This Bullbar will take approximately 3 hours to install

Tools required are

- Spanners and socket set.
- Screwdrivers
- Pliers and side cutters

Dobinsons BULLBARS should be installed by a qualified installer and it is the installer responsibility to ensure correct fitment.

Fully read and understand the instructions before beginning the installation



Part#
BU59-3511 &
BU59-3661
Fitting Instructions 2 of 2

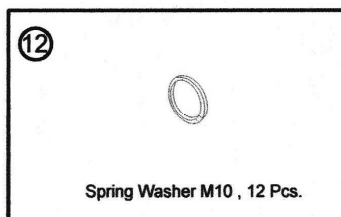
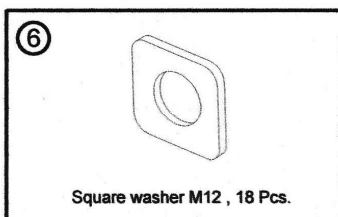
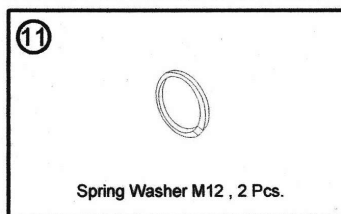
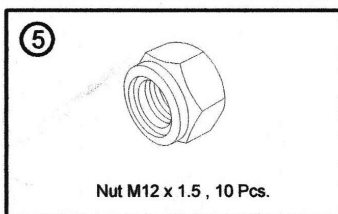
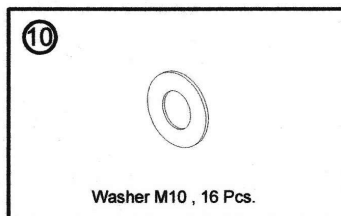
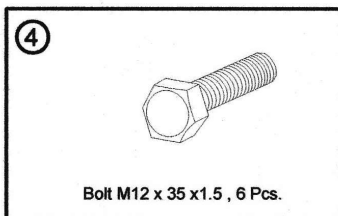
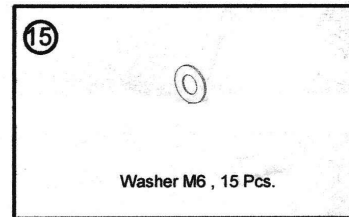
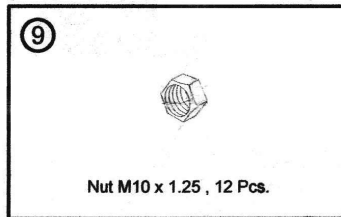
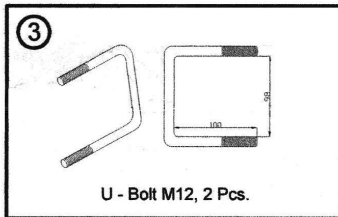
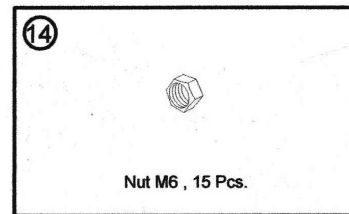
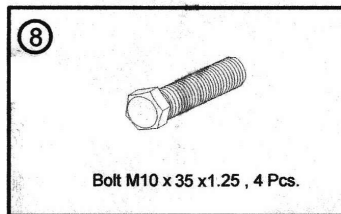
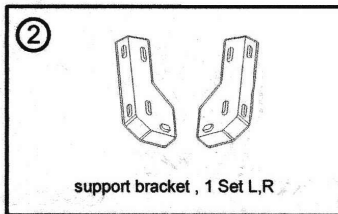
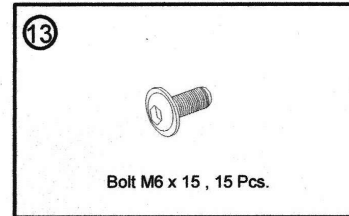
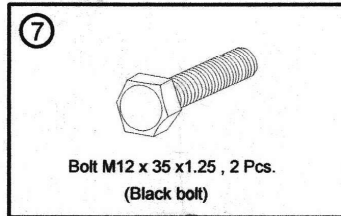
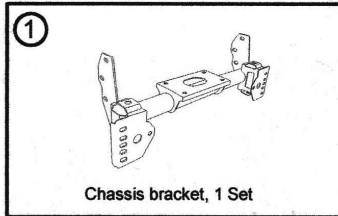



Part#
BU59-3511 &
BU59-3611
Fitting Instructions

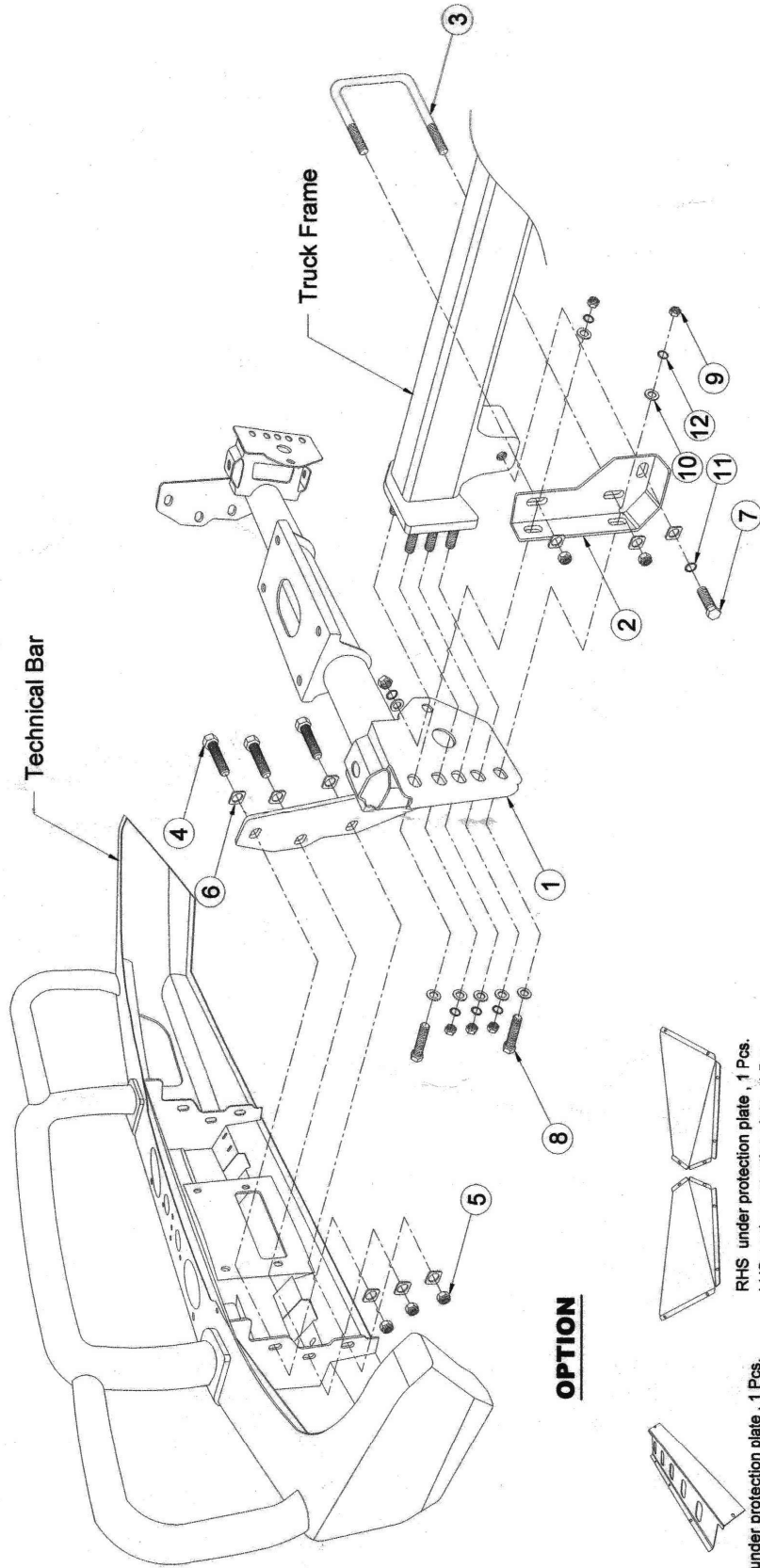

Fitting Guide

1. Remove the number plate and remove the grill.
2. Remove the clips along the top of the bumper, the bolts along the edge of the wheel arch and lower section of the bumper attaching the bumper to the vehicle.



3. Carefully unclip the bumper from the edges and under the headlights and carefully remove.



4. With the bumper off you can now remove the steel bumper mount and steel crush cans.



If removing the original bullbar some models require the bullbar to be removed first, then there are also bolts in the centre of the bullbar mounting crush cans that need to be removed as well before removing the original crush cans.



5. From inside the chassis rails loosely install the U-bolts supplied (item 3) facing out as seen on page 3.
6. Loosely install the small mounting brackets (item 2) to the outside of the chassis as per diagram on page 3.
7. Install the bullbar mounting bracket (item 1). Washers can be placed between the top and bottom bolts between items 1 and 2 to take up the gap as per the picture below. Ensure though that when tightening the bracket tightens correctly and the washers do not sit behind between the chassis and mounts.



8. Ensure the bracket is central to the vehicle and tighten all nuts and bolts installed in steps 5-7. Ensure when tightening that the u-bolts have sufficient clearance to the radiator support panel.
9. **(Lexus GX470 ONLY)** On the passenger's side of the vehicle, Pry open the transmission cooler bracket, remove the line and discard the bracket.

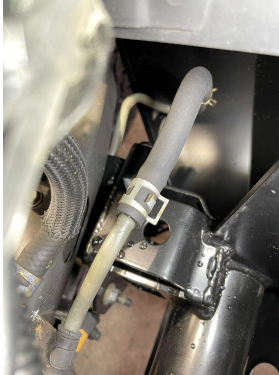

10. Carefully un-wrap the bulbar taking care not to scratch it especially on the top loops. Reinstall the number plate. If installing driving lights to the bullbar it is easiest to install now.
11. If not installing a winch skip to step 19.
12. See the Installation section of your Dobinsons 4x4 Winch manual for specific detailed fitting instructions. For a brief overview see the following steps.
13. Test fit your winch to the mounting bracket and do up loosely with the clutch handle on the left hand side of the vehicle.
14. Some vehicles may also require the air conditioner line to be relocated when installing a winch. Unclip the passenger side front mount, cut the mount shorter and drill a 6mm hole at the top of the mount and re-clip this to its new position.

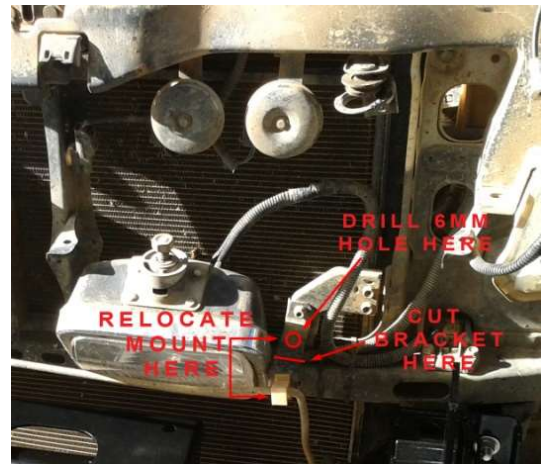

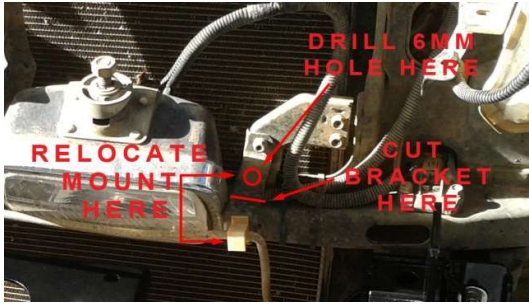

each side of the vehicle to prevent over spray and paint the lower stepped in lips of the vehicle satin black for a nicer finish, See before and after pictures below.



15. This may require the clutch handle and gear-box housing to be rotated forward one or 2 bolt holes to allow easy access through the bullbar holes. See instructions in winch user manual.
16. Determine where the winch control box will be located and mount the control box. See instructions in winch user manual for control box mounting options. If mounting to the top of the bullbar using the supplied bracket, check clearance of control box to grill and also check where the wires will route as if the wires are passing through the holes in the top of the bullbar the control box may not be able to be wired until the bullbar has been fitted as below.
17. Wire the winch up as per the winch instruction manual and bolt the winch to the mounting bracket, ensure the mounting bolts are not too long and tighten correctly. Route the wires and connect to battery and also route the breather hose.
18. Unwind some cable from the winch, and pass the cable through the fairlead hole in the bullbar and through the roller fairlead. This may require removing a circlip from the fairlead and re installing once the cable is passed through.
19. Install the roller fairlead into the bullbar.
20. Check the poly bullbar over riders, fog light and top loop bolts are tight (Do not over tighten the stainless steel loop mounting bolts. Do not over tighten the poly bullbar over riders as they will pull the over riders out of shape).
21. If the bullbar has not been colour matched the install may choose to carefully masking Dobinsons Springs and Suspension

22. With help, fit the bullbar onto the vehicle.
23. Align the bullbar to the vehicle and tighten the mounting bolts, leaving a gap between the bullbar wing and side guard of about 10-20mm.
24. **(Lexus GX470 ONLY)** Fender Flare trimming is required for proper fitment.



25. Wire up the lights. Using a multimeter or test light first locate the earth wire, parker positive www.dobinsonsprings.com

and indicator positive wires from the wiring on the back of the original vehicle lights on each side.

26. Unclip the wiring from the indicator/parker lights. Check that the wiring will be long enough to reach the new bullbar indicator/parker lights and extend if required. Using the diagram at the end of this manual, join the corresponding wires to original vehicle wires located in the previous step. The wires can be joined by either using good quality snap lock crimp connectors or by soldering. Ensure the connection is secure and is sufficiently insulated.
27. If fitting a bullbar with fog lights, the fog lights can be connected using the original vehicle fog light wires if fitted. If required, cut the old fog light wiring plugs off and cut the new fog light wiring plugs and join. If the vehicle is not fitted with OEM fog lights the wiring loom supplied can be used. Follow the wiring diagram at the end of this manual.
28. Check over all bolts to ensure they are tight.
29. Once happy with the alignment of the bullbar drill 2 x 8mm pinning holes on each side of the bullbar drilling through both the mounting bracket mounting plate and bullbar mounting plate. Fix with 8mm bolts and nyloc nuts to keep the bullbar in its position. *This is easiest done by drilling from the inside.*

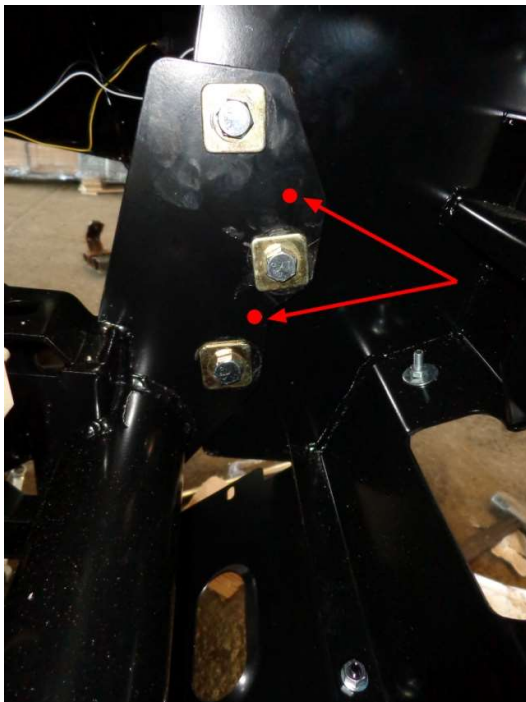

Dobinsons Springs and Suspension

30. Plug the wiring clips in for the fog lights and parker/indicator lights. Test all lights and adjust the position of the fog lights if required.
31. Using the fastening hardware supplied fit the under bar protection kit.
32. Trim the mud guard liners level with the bottom of the under protection kit and secure with cable ties.
33. Check over all items removed during installation.
34. **IMPORTANT NOTES:** It is important to inform the customer that headlight adjustment may also be required due to the change in ride height. It is also important to inform the customer that there will be a change in vehicle handling characteristics. It is also important to note that due to their nature fog lights are required to provide a yellow light to allow clear fog vision. For this reason Dobinsons bullbars utilise a Halogen bulb. Halogen bulbs generate a considerable amount of heat to achieve the yellow colour and this causes the air inside the fog light lens to expand and contract. For this reason the fog light assembly cannot be sealed and has a small breather on the back. In some cases this may cause condensation to form inside the fog light. The customer may choose to seal the lens of the fog light but must not seal the rear breather.

