

Bullbar Installation Guide



ENSURE PAGE SCALING IS TURNED

OFF WHEN PRINTING. CHECK TEMPLATE SCALE LINE FIRST

Part Number: BU59-3509 & BU59-3659

Fits:

Toyota Landcruiser 200 Series 2008 - 02/2012 only

Will Not Suit 2012 on face-lifted models



This Bullbar will take approximately 3 hours to install

Tools required are

- Spanners and socket set.
- Pneumatic hacksaw.
- Screwdrivers
- Pliers and side cutters

Dobinsons BULLBARS should be installed by a qualified installer and it is the installer responsibility to ensure correct fitment.

Fully read and understand the instructions before beginning the installation

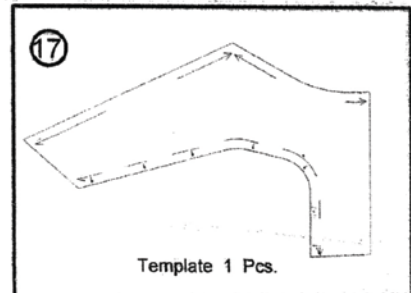
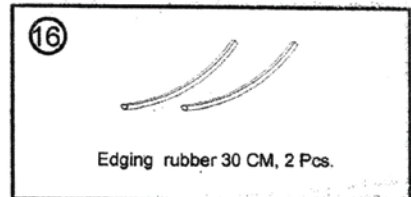
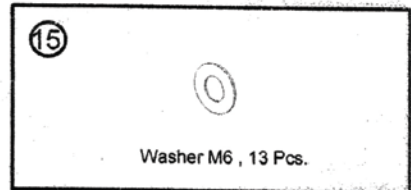
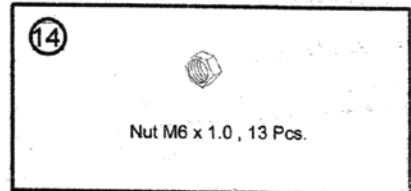
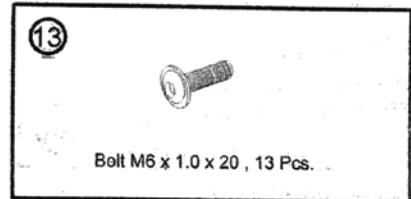
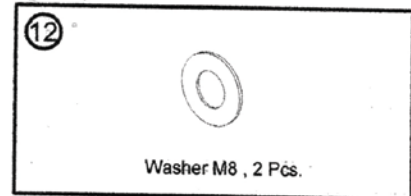
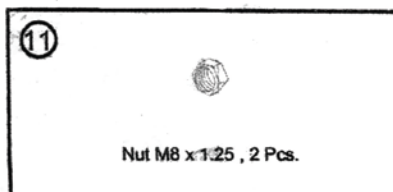
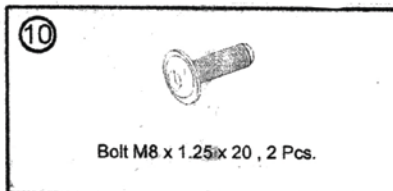
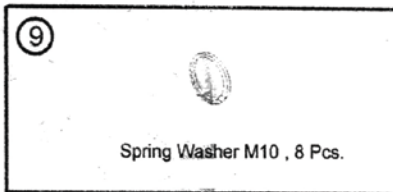
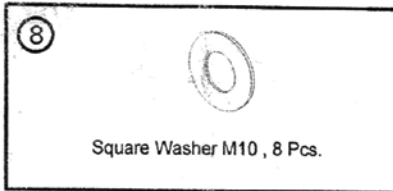
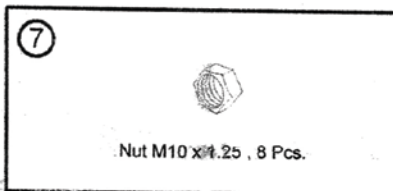
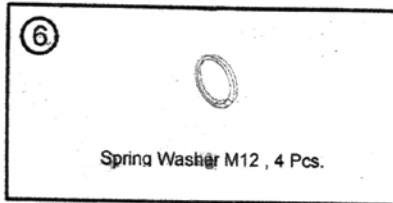
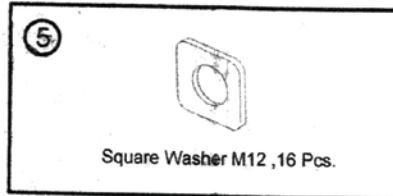
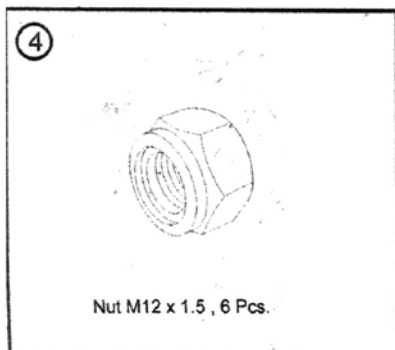
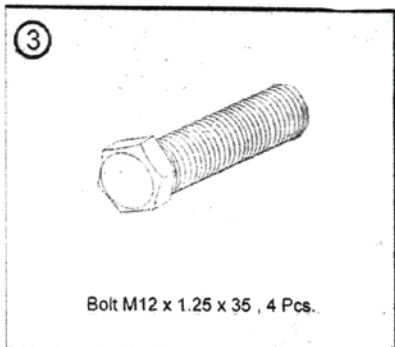
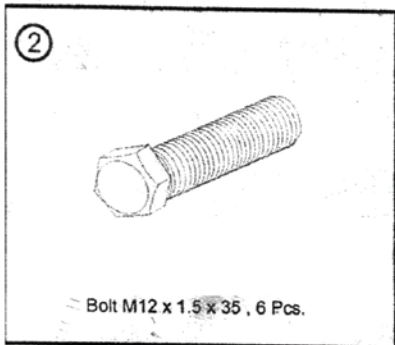
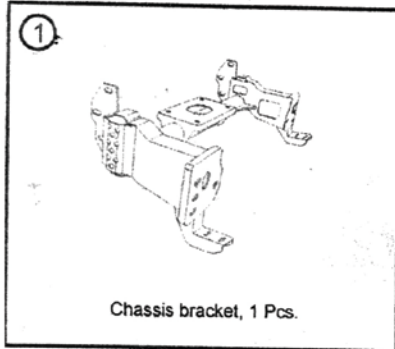



Part#
BU59-3509
BU59-3659

Fitting Instructions

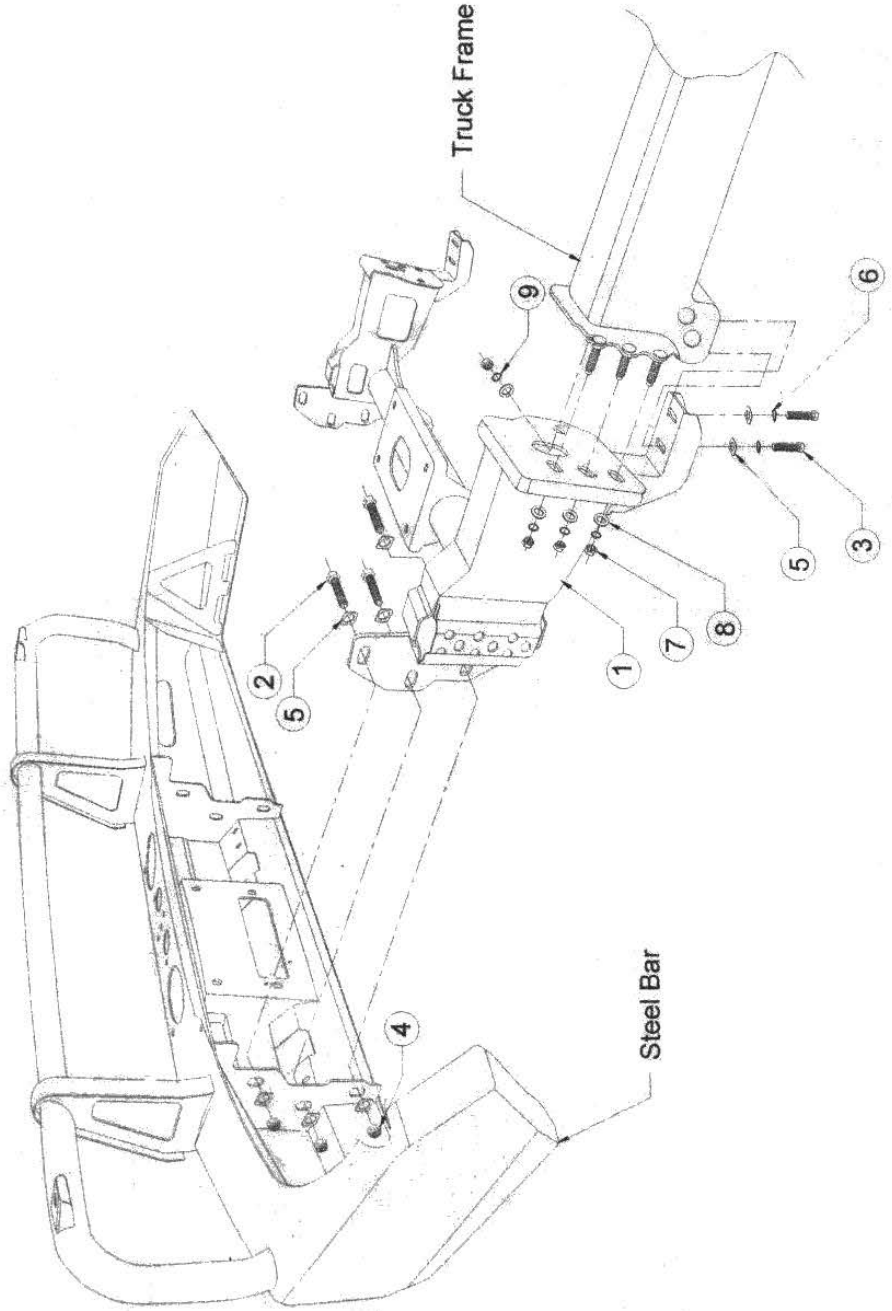

OPTION

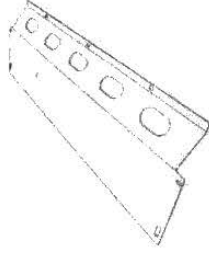

Middle under protection plate , 1 Pcs.

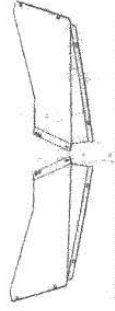

RHS under protection plate , 1 Pcs.
LHS under protection plate , 1 Pcs.

Fitting Guide

1. Remove the number plate.
2. Remove the grill by removing the bolts in the top and bottom, and then un-clipping the lower rectangular clips and the clips on the side. The side clips are quite difficult as they are hidden.



3. Using the template provided align it with the LH side of the OE bumper as seen on the template and mark out each side. The straight line on the bottom of the template can then be marked across to join parallel with the top edge of the grill section. You can then flip the template upside down to mark the RH side. It may be easier to cut the template out before doing this.

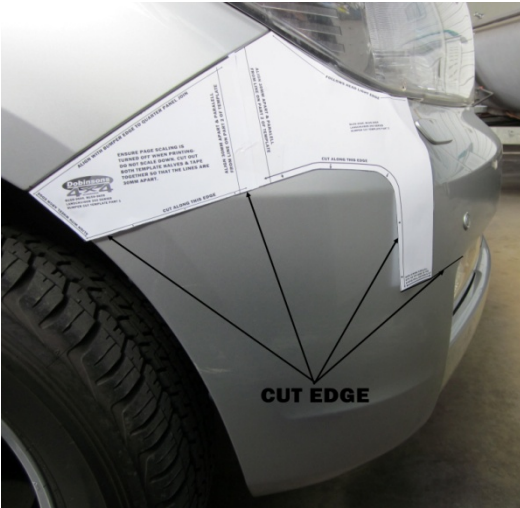

4. Remove the plastic protective plates underneath the OE bumper.
5. Remove the screws and scrivets on the OE bumper. They are located on the bottom and at the back on the inside of the wheel arch.
6. Now reach in from inside the wheel arch, and using a small flat point screw driver carefully



unclip the bumper underneath each headlight as seen below.



7. With the bumper off you can now remove the foam strip. Then remove the aluminium bumper mount.
8. Remove the factory bumper mounts and tow hooks.
9. Apply a small amount of masking tape around the edge of the marked line on the bumper.



10. Remove the Plastic grill and fog lights from the O.E. bumper
11. Using an air operated hacksaw or equivalent carefully cut away the lower section of the O.E. Bumper and cut vertical support sections in the grill section parallel with the top of the grill section. Remove plastic burrs to neaten up where cut was made. Fit the pinch weld rubber edging to the edge of the OE bumper where it was cut away, starting from the wheel arch edge. Ensure it is



- tight and the bottom of the pinch weld is up against the edge of the bumper neat.
12. Install the bulbar mounting bracket with the fastening hardware supplied. **NOTE: Some models may require notching of the lower bracket holes as there are some minor differences in bolt hole locations.**
 13. Carefully un-wrap the bulbar taking care not to scratch it especially on the top loops. Reinstall the number plate. If installing driving lights to the bullbar it is easiest to install now.
 14. If not installing a winch skip to step 25.
 15. See the Installation section of your Dobinsons 4x4 Winch manual for specific detailed fitting instructions. For a brief overview see the following steps.
 16. Test fit your winch to the mounting bracket and do up loosely with the clutch handle on the left hand side of the vehicle.
 17. You may have to cut and bend the centre brace to allow clear the winch drum as seen below.



18. This may require the clutch handle and gear-box housing to be rotated forward one or 2 bolt holes to allow easy access through the bulbar holes. See instructions in winch user manual.
19. Determine where the winch control box will be located and mount the control box. See instructions in winch user manual for control box mounting options. If mounting to the top of the bullbar using the supplied bracket, check clearance of control box to grill and also check where the wires will route as if the wires are passing through the holes in the top of the bullbar the control box may not be able to be wired until the bullbar has been fitted as below.
20. Now test fit the bumper to the vehicle again and you will see that you need to cut away

the centre section of the bumper to clear the winch, control box and clutch handle as seen below. Take small amounts away each time until you are happy with the access.

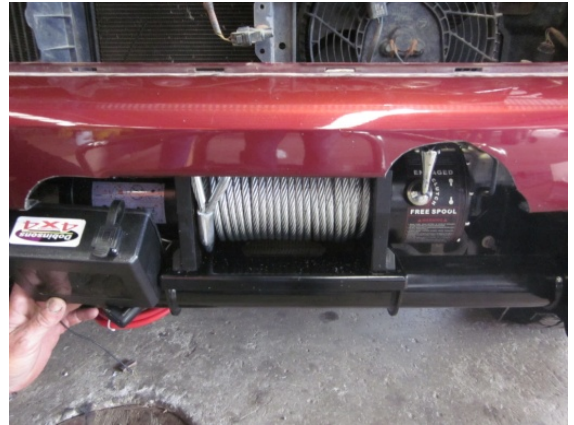

21. Wire the winch up as per the winch instruction manual and bolt the winch to the mounting bracket, ensure the mounting bolts are not too long and tighten correctly. Route the wires and connect to battery and also route the breather hose.
22. Reinstall the bumper and grill.
23. Unwind some cable from the winch, and pass the cable through the fairlead hole in the bullbar and through the roller fairlead. This may require removing a circlip from the fairlead and re installing once the cable is passed through.
24. Install the roller fairlead into the bulbar.
25. Check the poly bulbar over riders, fog light and top loop bolts are tight (Do not over tighten the stainless steel loop mounting bolts. Do not over tighten the poly bulbar over riders as they will pull the over riders out of shape).
26. With help, fit the bulbar onto the mounting bracket and loosely fit the mounting hardware supplied.
27. Align the bulbar to the vehicle and tighten the mounting bolts.
28. Once happy with the alignment of the bullbar drill 2 x 8mm pinning holes on each side of the bullbar drilling through both the mounting bracket mounting plate and bullbar mounting

plate. Fix with 8mm bolts and nyloc nuts to keep the bullbar in its position.

29. Wire up the lights. Using a multimeter or test light first locate the earth wire, parker positive and indicator positive wires from the wiring on the back of the original vehicle lights on each side.
30. Unclip the wiring from the indicator/parker lights. Check that the wiring will be long enough to reach the new bullbar indicator/parker lights and extend if required. Using the diagram at the end of this manual, join the corresponding wires to original vehicle wires located in the previous step. The wires can be joined by either using good quality snap lock crimp connectors or by soldering. Ensure the connection is secure and is sufficiently insulated.
31. If fitting a bullbar with fog lights, the fog lights can be connected using the original vehicle fog light wires if fitted. If required, cut the old fog light wiring plugs off and cut the new fog light wiring plugs and join. If the vehicle is not fitted with OEM fog lights the wiring loom supplied can be used. Follow the wiring diagram at the end of this manual.
32. Plug the wires into the indicator, parker light plug and fog lights. Test all lights and adjust the position of the fog lights if required.
33. Check over all bolts to ensure they are tight.
34. Using the fastening hardware supplied fit the under bar protection kit.
35. Trim the left hand and right hand mud guard liners flush with the bottom of the under protection plates and secure.
36. Check over all parts removed during installation.
37. **IMPORTANT NOTES:** It is important to inform the customer that headlight adjustment may also be required due to the change in ride height. It is also important to inform the customer that there will be a change in vehicle handling characteristics. It is also important to note that due to their nature fog lights are required to provide a yellow light to allow clear fog vision. For this reason Dobinsons bullbars utilise a Halogen bulb.



Halogen bulbs generate a considerable amount of heat to achieve the yellow colour and this causes the air inside the fog light lens to expand and contract. For this reason the fog light assembly cannot be sealed and has a small breather on the back. In some cases this may cause condensation to form inside the fog light. The customer may choose to seal the lens of the fog light but must not seal the rear breather.

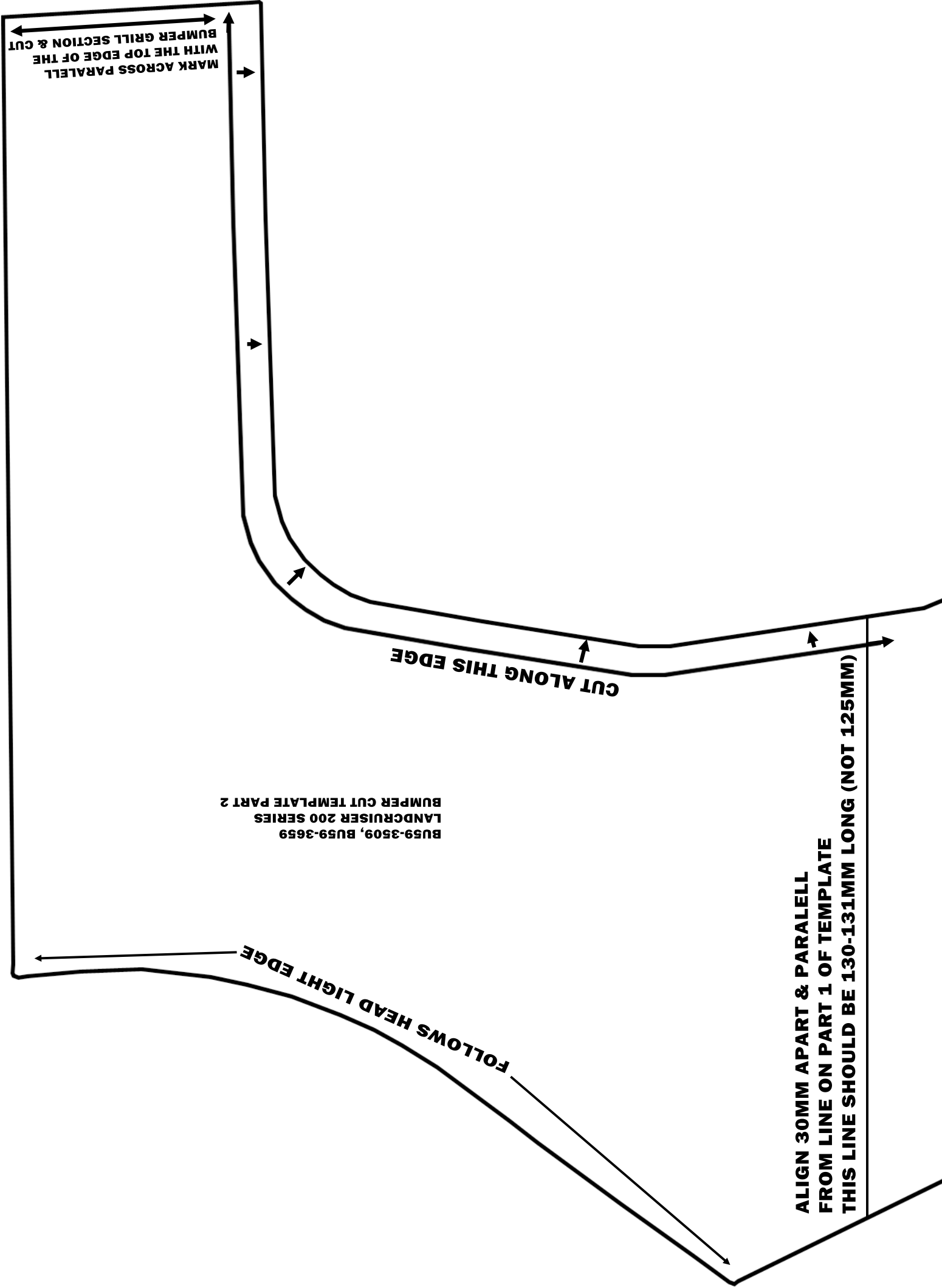

MARK ACROSS PARALELL
WITH THE TOP EDGE OF THE
BUMPER GRILL SECTION & CUT

CUT ALONG THIS EDGE

BU59-3509, BU59-3659
LANDCRUISER 200 SERIES
BUMPER CUT TEMPLATE PART 2

FOLLOWS HEAD LIGHT EDGE

ALIGN 30MM APART & PARALELL
FROM LINE ON PART 1 OF TEMPLATE
THIS LINE SHOULD BE 130-131MM LONG (NOT 125MM)

ALIGN WITH BUMPER EDGE TO QUARTER PANEL JOIN

**ENSURE PAGE SCALING IS
TURNED OFF WHEN PRINTING-
DO NOT SCALE DOWN. CUT OUT
BOTH TEMPLATE HALVES & TAPE
TOGETHER SO THAT THE LINES ARE
30MM APART.**

ALIGN 30MM APART & PARALLEL
FROM LINE ON PART 2 OF TEMPLATE



**BU59-3509, BU59-3659
LANDCRUISER 200 SERIES
BUMPER CUT TEMPLATE PART 1**

CUT ALONG THIS EDGE

ALIGN WITH WHEEL ARCH EDGE

FOG LIGHT WIRING DIAGRAM

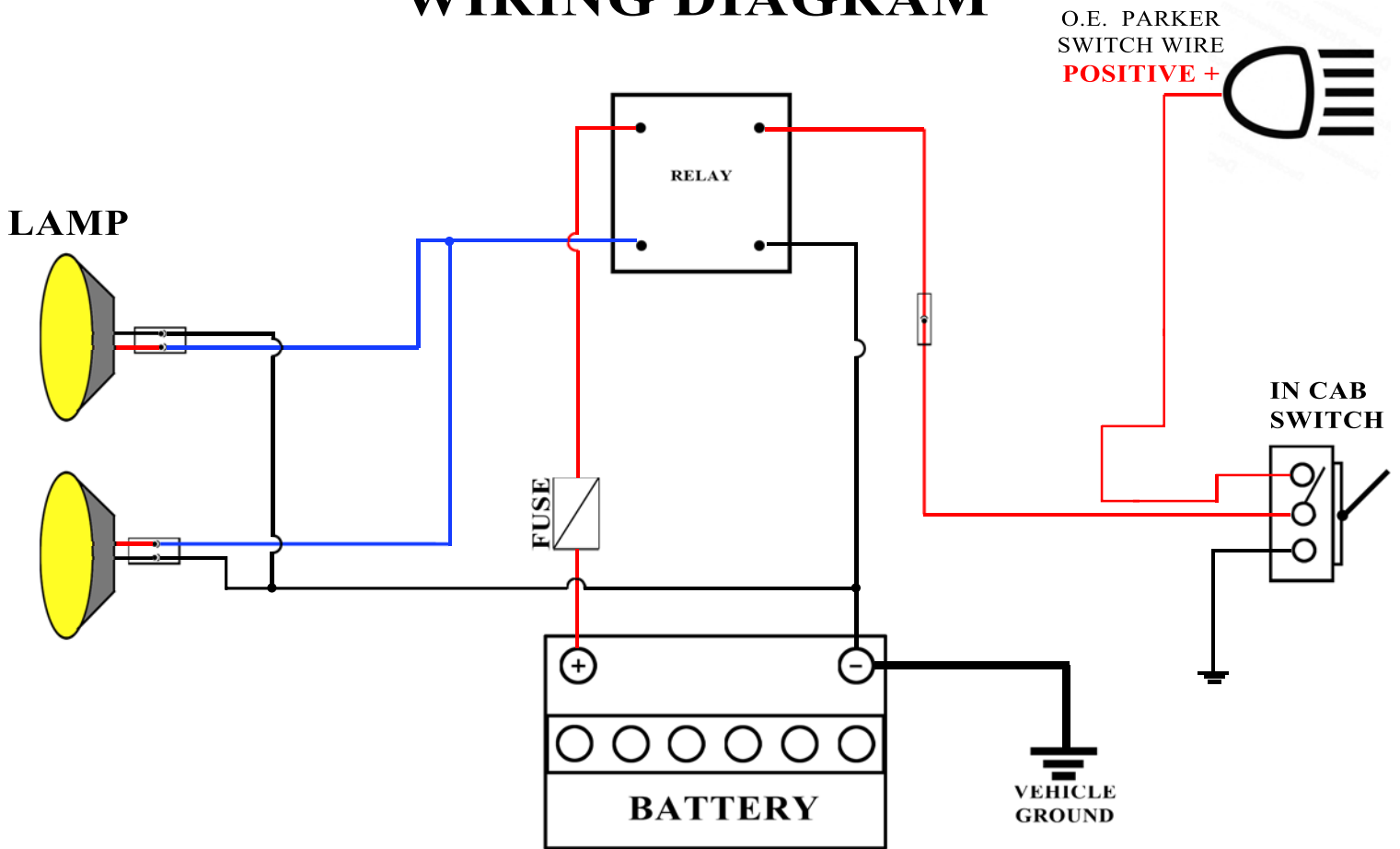

CHECK THE PARKER/INDICATOR WIRING LIGHT CONFIGURATION AND USE THE CORRECT WIRING DIAGRAM AS SEEN BELOW

TYPE 1 - YELLOW, BLACK WHITE FROM LIGHT AND CONNECTOR

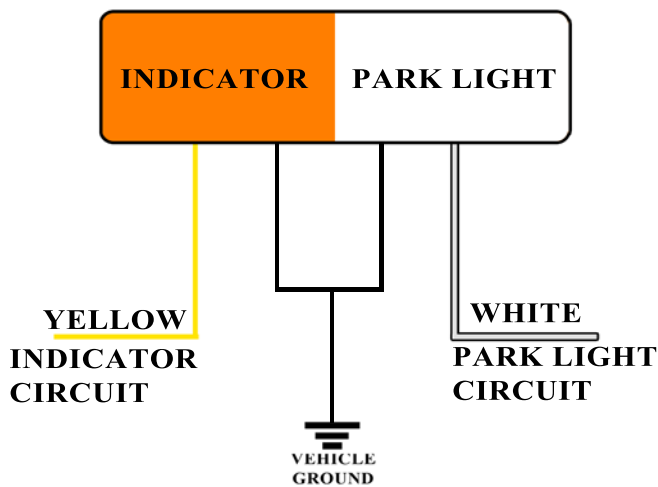

TYPE 2 - YELLOW, WHITE, BROWN FROM LIGHT BLACK, WHITE, RED FROM CONNECTOR

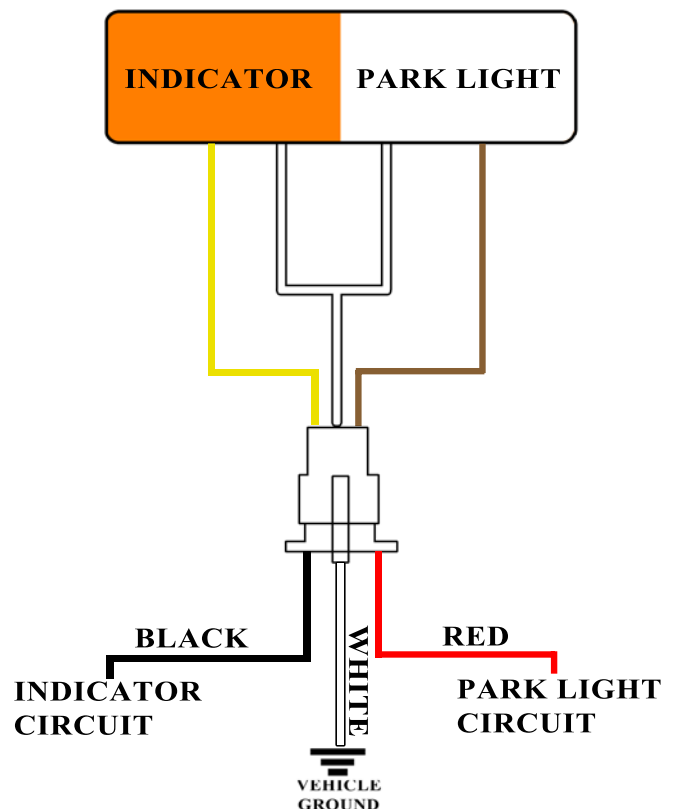

Customer Copy: Bullbar Care Instructions



To ensure the surface finish quality it is recommended that the bullbar be washed and cleaned regularly to prevent build up of dirt and contaminants which when exposed to the elements can degrade the surface finish. It is also recommended that the mounting fasteners on the bullbar be checked after 1000km's. Winch servicing and care should also be carried out as per the winch instruction manual.

Stainless Loop Deluxe Bullbar Loop Care and Maintenance

(Customers with Stainless Loop Deluxe Models Only)

The top loops on your Dobinsons Stainless Loop Deluxe steel bullbar are manufactured from high quality 304 grade stainless steel. Once formed and welded it is highly polished to provide a high gloss finish. Whilst the material is a high quality stainless steel, like any other exterior polished surface, care and some maintenance is required to ensure the surface finish quality.

It is recommended that the stainless loops be kept as clean as possible and is thoroughly washed and dried regularly to prevent build up of dust and contaminants. This is especially important in coastal and high dust areas. The loops can simply be cleaned with most regular car cleaning items like a soft sponge, car wash and a chamois, avoid strong cleaning chemicals. Like many other highly polished exterior metals, over extended periods of time and heavy weathering can cause some staining of the surface may occur. If this occurs the surface can be simply polished using the following methods to remove the stains and restore the high gloss surface using simple tools and cheap readily available polishing items.

Tools Required:

- Electric buffer or Electric drill (an electric/cordless drill is generally more convenient).
- Polishing compound – This can be supplied by Dobinsons Spring and Suspension. Please contact head office on the details below for polish, as a specific type is used.
- Soft finishing type buffing wheel – The buffing wheel should be a soft, finishing type/Calico loose leaf style to allow the surface to be polished to a high gloss without further marking the surface. The 2 types of discs shown below are readily available from most hardware stores (Australian customers – Bunnings etc). The brand below is Josco, and if purchasing a twin pack ensure that only the finishing buff is used and not the cutting buff. **DO NOT USE METAL OR HARSH BUFFING PADS.**



Method

1. The stainless loops may be removed from the bullbar if this makes it easier to work on, however if using a cordless drill this is not a necessity. If removing the loops, do not over tighten the loop retaining bolts when re fitting.
2. Ensure the loops are first completely clean and dry.
3. Fit the polishing buff wheel to the drill or buffing tool –take note of the maximum wheel speed and rotation direction.
4. It is recommended to follow specific instructions on the packaging of the buffing wheel for best results. However if no instructions are provided the following guidelines can be used:
 - A). Carefully dress the buff wheel with the compound across the rotating wheel for a few seconds, taking care not to apply too much compound, it is better to apply a little compound more frequently than to overdress the buff.



- B). Gently buff the work area with the buffing wheel and with light pressure move back and forth across the job.



- C). After polishing use a soft, clean, dry rag to clean the surface and inspect in the light for an even finish.
- D). Once complete clean thoroughly again with a sponge and warm water.