

Rollout Awning

CE80-3904, CE80-3933, CE80-3934



The Dobinsons Rollout Awning can be fitted in a number of different ways to different types of roof bars/rails and roof racks

Tools required are

- Spanners and socket set.
- Screwdrivers
- Pliers and side cutters
- Drill and Drill Bits

Fully read and understand the instructions before beginning the installation

Fitting Guide

Your Dobinsons 4x4 Rollout Awning has been designed for universal fitment to most makes and models of four wheel drives and commercial vehicles. Your awning can be mounted in 4 different styles as outlined below. Your awning can either be mounted directly to a roof rack, on the aluminum cross rails provided (best for Roof Bar/Rail Systems), directly onto roof rails that run across the vehicle or directly to the top of a reinforced canopy. It is important when mounting the awning to ensure it is positioned to allow sufficient clearance for the vehicle doors to open.

Option 1 - Mounting Directly to a Roof Rack

1.1 Slide the small bolts into the mounting rail of the awning, as seen in the picture to the right.



1.2 With help from another person hold the awning in the place and mark the mounting holes for the awning, it is best to have the mounting bolts as far apart as possible.

1.3 Carefully drill the holes into the roof rack.

1.4 Align awning into desired position and tighten the nuts.

1.5 Re-check all nuts and bolts periodically.

1.6 Alternatively if mounting the awning to a roof top tent rack the "L" shaped brackets may be used as seen below (similar to option 3), by bolting the long side of these brackets to the underside of the flat plates where the roof rack meets the roof rack bracket.



Option 2 – Utilizing the Aluminium Mounting Rails (Recommend for Roof Bars/Rails that run lengthways front to back on the vehicle)

2.1 Install the long bolts into the slide plates, and slide 2 plates into each corner of the mounting rails.

2.2 Sit both cross braces on the Roof bars/Roof Rack Rails central, the 2 slide plates each corner will sit either side of the roof rails, with a base plate underneath to clamp to each rail. One end of the cross braces will have 2 holes drilled on the flat side to suit the "L" shaped brackets, this end is for the awning mount and goes to side of the vehicle to which the awning will be mounted. Both braces should be separated as far as possible to provide stability.



2.3 Ensure that the cross braces are positioned to allow the awning to be reached easily, and is also clear of moving parts. If required the mounting rails can be marked and cut down shorter, depending on the width of the roof rails.

2.4 Loosely fit the base clamping plate under the Rail or Bar and fit a nyloc nut on each bolt on each end of both braces as seen to the right, as to clamp the rail. It is best not to fully tighten the nuts yet to allow adjustment when finished.

2.5 Slide 2 x 6mm nyloc nuts into the rail on the flat side of each of the mounting ends of the cross braces, so they line up with the 2 mounting holes.

2.6 Using the small bolts mount the long side of the "L" shaped bracket to the cross braces, screwing the bolts into the nuts inserted in step 5.

2.7 Slide the small bolts into the mounting rail of the awning.

2.8 With help from another person hold the awning in the place and line up the 8mm bolts inserted in step 6 with the "L" shaped bracket and fit nyloc nuts.

2.9 Align awning into desired position and tighten all nuts and bolts from Steps 2.1 – 2.8.

2.10 Insert rubber end caps into cross braces.

2.11 Re-check all nuts and bolts periodically.

Option 3 - Mounting directly to Roof Cross Bars

3.1 Ensure that the roof bars are of enough distance apart to provide sufficient stability.

3.2 Align the long side of the "L" shaped brackets on to the roof bars as seen to the right, with the brackets in a suitable position to allow easy access to the awning, without it protruding to far from the side of the vehicle.

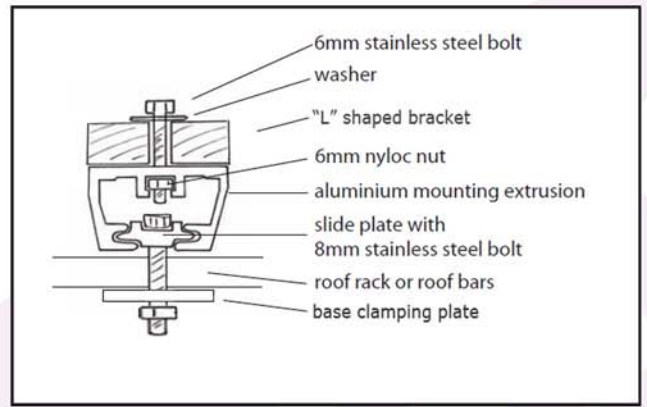

- 3.3 Mark the holes and centre punch.
- 3.4 Drill the holes to clear the long bolts.
- 3.5 Bolt the “L” shaped brackets to the roof bars.
- 3.6 Slide the head of the small bolts into the mounting rail of the awning.
- 3.7 With help from another person, position the awning onto the “L” shaped brackets and install the nyloc nuts.
- 3.8 Align awning into desired position and tighten all nuts and bolts from Steps 3.1 – 3.7.
- 3.9 Re-check all nuts and bolts periodically.



Option 4 - Mounting directly to a Re-inforced Steel/Alloy Canopy

If mounting directly to the roof of a canopy or trailer it is recommended that the “L” shaped brackets are mounted to cross braces built into the canopy and not directly the sheet metal, as this will support the weight of the awning correctly.

- 4.1 Slide the smaller bolts into the mounting rail of the awning.
- 4.2 Loosely bolt the short side of the “L” shaped brackets to the canopy.
- 4.3 With help from another position the awning on the canopy. Ensure the brackets are square, in line and ensure the awning will be able to function correctly, will clear moving parts and is easy to access and operate. It is best to have the 2 brackets separated as far as possible for stability.
- 4.4 Mark the mounting holes and remove the awning.
- 4.5 Drill the holes in the canopy to clear the mounting bolts.
- 4.6 Refit the awning to the canopy with the bolts supplied.
- 4.7 Align awning into desired position and tighten all nuts and bolts from Steps 4.1 – 4.6.
- 4.8 Re-check all nuts and bolts periodically.

5. Setup Procedure

- 5.1 Undo the zipper on the protective bag and whilst holding the awning in place, release the captive buckles.
- 5.2 Still holding the awning, gently swing out both awning rafter arms slightly past 90° away from the vehicle to allow the awning to roll out between them.

- 5.3 Holding the awning in your hands, unroll it to its full length, taking care as you get to end as the 2 legs may have come loose during travel. Pull the extensions of the rafter arms out longer as you unroll the awning.
- 5.4 Carefully release the legs from inside the channel, and with one hand holding the centre of the awning, set each leg to the desired height and twist the bottom half of the leg to lock.
- 5.5 Whilst holding the awning end beam with one arm, slide out each rafter arm, aligning the end pin into the end beam holes and twist the arm to lock in position.
- 5.6 Fix the awning material to the rafter arms using the Velcro straps.
- 5.7 Using the pegs and guy ropes secure the awning front beam diagonally outwards to secure the legs.
- 5.8 Pack away is a reverse of the steps 1 – 7. Be sure to roll the awning material underneath itself. Avoid packing away the awning wet, if the awning has been stored wet, open it and allow it to dry.

Always set up awning with sufficient angle to allow the water to run off and not pool on top of the awning.

6. Care Instructions

- 6.1 Clean only with cold water and a soft brush - do not use soap or detergent.
- 6.2 Do not expose to petrol, oil or solvents.
- 6.3 Avoid creases and seams when rolling up the awning.

7. Warranty Terms and Conditions

Dobinsons Spring & Suspension at its sole discretion will repair or replace any products supplied by them that are found to be defective in either materials or workmanship providing that Dobinsons Spring & Suspension are actually notified in writing from the Client of the alleged defect within one year (1 year) from date of invoice for awnings. Any claim not made within this period shall conclusively be deemed waived by the Client. Repair or replacement is pre-conditioned on the examination of the goods which on instructions from Dobinsons Spring & Suspension on, should be returned for further inspection to Dobinsons Spring & Suspension or to an Approved Distributor.

Dobinsons Spring & Suspension will not pay for costs incurred in forwarding or returning goods. This warranty does not cover and Dobinsons Spring & Suspension makes no warranty with respect to; (1) abuse, misuse, misapplication, neglect or modification; improper or incorrect installation or improper maintenance; collision (2) Goods no longer required by Client; (3) Goods incorrectly chosen by Client; (4) Goods modified or altered by client; Dobinsons Spring & Suspension shall not be liable for any expenses incurred by Client in order to remedy any defect in its product. Dobinsons Spring & Suspension shall not be liable for any consequential, special, indirect or contingent damage or expense arising Directly or Indirectly from any defect in its products or from use of any products. This warranty does not cover the removal, installation or re-installation of the product. Dobinsons Spring & Suspension reserves the right to change the product design without notice. Under circumstances in which Dobinsons Spring & Suspension have changed a product design, Dobinsons Spring & Suspension shall have no obligation to upgrade or otherwise modify previous product.



HEAVY DUTY RAISED SUSPENSION KITS

ROOF RACKS & ROOF TOP TENT RACKS



WINCH & AIRBAG COMPATIBLE STEEL BULLBARS



ROOF TOP TENTS RECOVERY GEAR AND MUCH MORE

