



Osmo

Change Table "Beech"

#092243-136



**IMPORTANT:
RETAIN FOR FUTURE REFERENCE,
READ CAREFULLY**

Read all instructions before assembly and use of the change table.
Keep instructions for future use.

⚠ WARNING ⚠

ADULT ASSEMBLY REQUIRED:

DUE TO THE PRESENCE OF SMALL PARTS DURING ASSEMBLY, KEEP OUT OF REACH OF CHILDREN UNTIL ASSEMBLY IS COMPLETE.

DO NOT LEAVE THE CHILD UNATTENDED ON THE CHANGE TABLE.

TO PREVENT FALLS, DO NOT USE CHANGE PAD WITH A THICKNESS OF MORE THAN 30MM.

WHEN LOCKABLE CASTORS/WHEELS ARE FITTED, THEY SHOULD BE LOCKED WHEN THE CHANGE TABLE IS IN USE.

FOLLOW THE MANUFACTURER'S ASSEMBLY INSTRUCTIONS TO ENSURE THE SAFETY FEATURES OF THE COT ARE NOT COMPROMISED.

All assembly fittings should always be tightened properly and checked regularly.

To prevent falls, do not leave your baby unattended on the change table.

Both brakes on the castors must be applied before placing your baby on the change table.

DISCONTINUE use once child reaches **12 months** of age or **11kgs**.

DO NOT allow older children to climb or play on the change table.

DO NOT use parts other than those supplied and approved by CNP Brands.

Promptly replace worn out or broken parts.

DO NOT over tighten the bolts.

Be aware of the risk of open fires and other sources of strong heat, such as electric bar fires, gas fires etc. in close vicinity to the change table.

DO NOT use this change table if any part is broken, torn or missing.

ENSURE children are clear of any moving parts when adjusting the change table.

For warranty purposes, keep your sales receipt to provide proof of purchase.

RECOMMENDED CHANGE PAD (SOLD SEPARATELY):

THIS CHANGE TABLE HAS BEEN MANUFACTURED FOR USE WITH A CHANGE PAD WHICH MEASURES 750MM LONG X 500MM WIDE X 30MM IN THICKNESS.

We recommend the Childcare Universal Change Pad model #115153-003 to use with this change table. Place change pad on top of the change table ready for use.

Congratulations on your purchase of the **Osmo Change Table**

This product has been designed and developed with safety, comfort and functionality in mind. Please take the time to read this manual carefully before using this product and keep it in a safe place for future reference.

Contents

Assembly contents list

Assembly / Operating instructions

How to care for your **Osmo Change Table**





Due to variations in the style and design of our products, the photographs and illustrations shown in this instruction manual are generic, therefore product fabrics, colour and design may vary from images shown. CNP Brands reserves the right to alter product specifications without notice as a result of our ongoing policy of product improvement.

Check what you have received...

You have received **1 box**. Please check the contents of the box against the list below. If anything is missing, please contact Customer Service.

In Australia, contact **CNP Brands on 1300 667 137**, in New Zealand contact **Wainhouse Distribution on 0800 567 5000**.

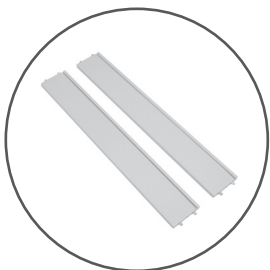
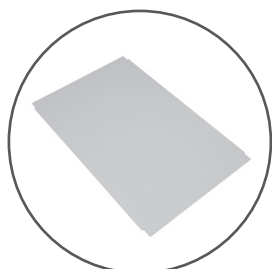
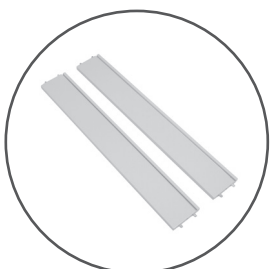
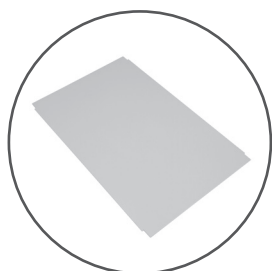
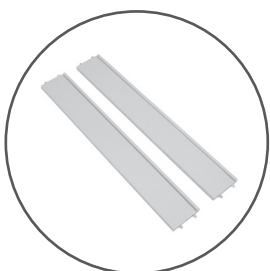
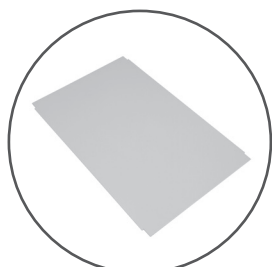
Supplied loose in box:

End Panel		x 2	Top Side Rail		x 2
Top Shelf		x 1	Middle Side Rail		x 2
Middle Shelf		x 1	Bottom Side Rail		x 2
Bottom Shelf		x 1	38mm Bolt		x 16

Recommended use with 115153-003 Universal Change Pad - White.

Allen Key



x 1

- a. As small parts are involved in assembly, children should be kept clear of the assembly area.
- b. Dispose of all packaging material immediately after the change table is assembled.
- c. Identify all parts and components.
- d. Clear an area on the floor for assembly and place a sheet on the floor to ensure the change table is not scratched during assembly.

⚠ WARNING ⚠

DO NOT OVERTIGHTEN BOLTS. OVERTIGHTENING BOLTS CAN CAUSE PANELS TO CRACK.

To assemble Change Table...

1

- 1a. Lay one **End Panel** on its side.
- 1b. Insert one **Top Side Rail** into position and secure with 2 x **38mm Bolts**.
- 1c. Ensure the grooves on the **Top Side Rail** are on the bottom side of the rail and are facing inward.
- 1d. Repeat for second **Top Side Rail**.

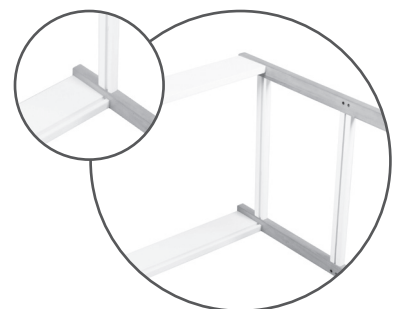

2

- 2a. Insert one **Middle Side Rail** into position and secure with 1 x **38mm Bolt**.
- 2b. Ensure the grooves on the **Middle Side Rail** are facing inward.
- 2c. Repeat for second **Middle Side Rail**.

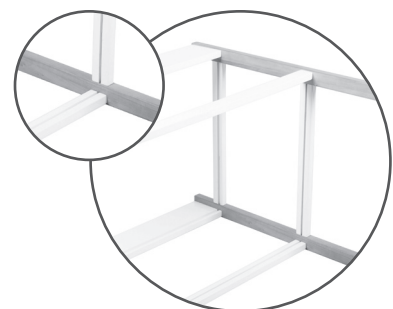

To assemble Change Table continued...

3

- 3a. Insert one **Bottom Side Rail** into position and secure with 1 x **38mm Bolt**.
- 3b. Ensure the grooves on the **Bottom Side Rail** are facing inward.
- 3c. Repeat for second **Bottom Side Rail**.

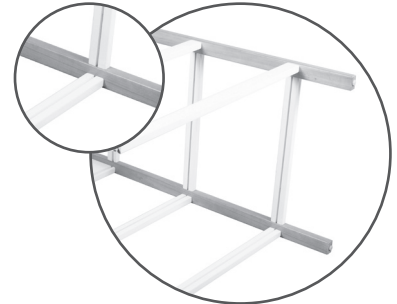

4

- 4a. Carefully flip the change table onto the assembled headboard.
- 4b. Slide **Top Shelf** into position along the grooves of the **Top Side Rails**.
- 4c. (The **Top Shelf** is the **thickest** of the three shelves).



5

- 5a. Slide **Middle Shelf** into position along the grooves of the **Middle Side Rails**.
- 5b. Slide **Bottom Shelf** into position along the grooves of the **Bottom Side Rails**.

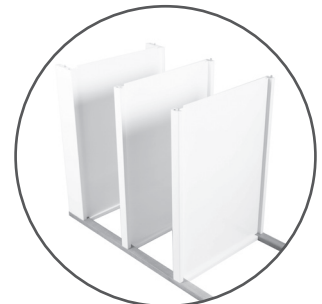

6

- 6a. Place the remaining headboard onto the shelves making sure each shelf sits in the headboard grooves.



7

- 7a. When the headboard is in position, secure with the remaining 8 x **38mm Bolts**.



The Change Table is now ready for use.



Cleaning

This product has been designed and developed with safety, comfort and functionality in mind. Please take the time to read this manual carefully before using this product and keep it in a safe place for future reference.

To ensure the long-lasting use of your change table, wipe down with a damp cloth and use a mild soap solution if necessary. Do not use abrasive cleaners. Always store product in a clean dry place.

Maintenance

Always check parts regularly for tightness of screws, nuts and other fasteners – tighten or replace if required. To maintain the safety of your change table, seek prompt repairs for bent, torn, worn or broken parts. Use only those parts and accessories approved by **CNP Brands**.

If you have any difficulties in assembling the change table, please contact our Service Department.

In Australia, contact **CNP Brands on 1300 667 137**, in New Zealand contact **Wainhouse Distribution on 0800 567 5000**.



CNP BRANDS

CHILDCARE NURSERY PRODUCTS | EST. 1899



Distributed in Australia by CNP Brands
Customer Service 1300 667 137

W: www.cnpbrands.com.au
E: info@cnpbrands.com.au
F: www.facebook.com/CNPBrands
I: @cnp_baby

Distributed in New Zealand by Wainhouse
Distribution

2-6 Argyle St, Morningside,
PO Box 41-014,
St Lukes, Auckland, New Zealand
Customer Service: 0800 567 5000

E: helpline@wainhousedist.co.nz

