

BRISTOL TWO TIER

Change Table Model # 092119

IMPORTANT:

RETAIN FOR FUTURE REFERENCE, READ CAREFULLY



Safety Precautions



Before assembling this change table read and understand the instruction. Incorrect assembly may make the change table unsafe. Do not use this change table if any part is broken, torn or missing. Keep these instructions in a safe place for future reference.

⚠️ WARNING

**NEVER LEAVE CHILD UNATTENDED ON CHANGE TABLES.
TO PREVENT FALLS, DO NOT USE CHANGE PAD WITH A THICKNESS OF MORE THAN 30MM.
WHEN LOCKABLE CASTORS/WHEELS ARE FITTED, THEY SHOULD BE LOCKED WHEN THE CHANGE TABLE IS IN USE.**

All assembly fittings should always be tightened properly and checked regularly.
To prevent falls, do not leave your baby unattended on the change table.
Both brakes on the castors must be applied before placing your baby on the change table.
Discontinue use once child reaches 12months or 11kg.
Do not allow older children to climb or play on the change table.
Do not use accessories other than those supplied and approved by Childcare Nursery Products.
Promptly replace worn out or broken parts.
Do not overtighten the bolts.
Ensure the change table is placed at a reasonable distance away from open fires and other sources of strong heat, such as electric bar fire, gas fire, etc.
Do not use this change table if any part is broken, torn or missing.
Ensure children are clear of any moving parts when adjusting the change table.
For warranty purposes, keep your sales receipt to provide proof of purchase.

RECOMMENDED CHANGE PAD SIZE (NOT SUPPLIED):

This change table has been manufactured for use with a change pad which measures 750mm long x 500mm wide x 30mm in thickness.

We recommend the Childcare Universal Change Pad model #115140-003 to use with this change table. Place change pad on top of the change table ready for use.

Congratulations on your purchase of the Childcare Change Table.

This product has been designed and developed with safety, comfort and functionality in mind. Please take the time to read this manual carefully before using this product and keep it in a safe place for future reference.

Contents

Assembly contents list

Assembly / Operating instructions

How to care for your Childcare Change Table



Due to variations in the style and design of our products, the photographs and illustrations shown in this instruction manual are generic, therefore product fabrics, colour and design may vary from images shown. CNP Brands reserves the right to alter product specifications without notice as a result of our ongoing policy of product improvement.

Assembly Contents



Check what you have received...

You have received 1 box. Please check the contents of the box against the list below. If anything is missing, please contact Customer Service. In Australia, contact CNP Brands on 1300 667 137, in New Zealand contact Wainhouse Distribution on 0800 567 5000.

Supplied loose in box:

Headboard

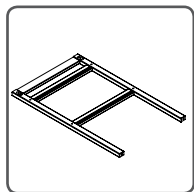

x1

Foot end

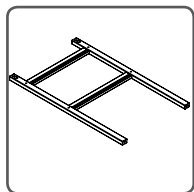

x1

Shelf

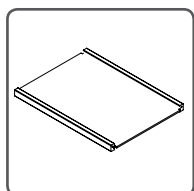

x2

Assembly Contents



Check what you have received cont...

Top side rail

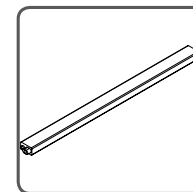

x2

Bolts (c)

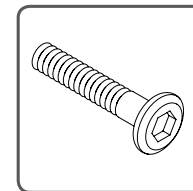

x12

Allen key (e)

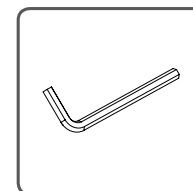

x1

Assembly / Operating Instructions



As small parts are involved in assembly, children should be kept clear of the assembly area. Dispose of all packaging material immediately after the change table is assembled. Identify all parts and components. Clear an area on the floor for assembly and place a sheet on the floor to ensure the change table is not scratched during assembly.

Assembling shelves

1. Attach both shelves into the headboard as per the diagram by aligning the shelves grooves with the headboards slots.
2. Insert a bolt (c) in each end of the headboard for each shelf. Ensure they are secure by the allen key (e), but not tight.

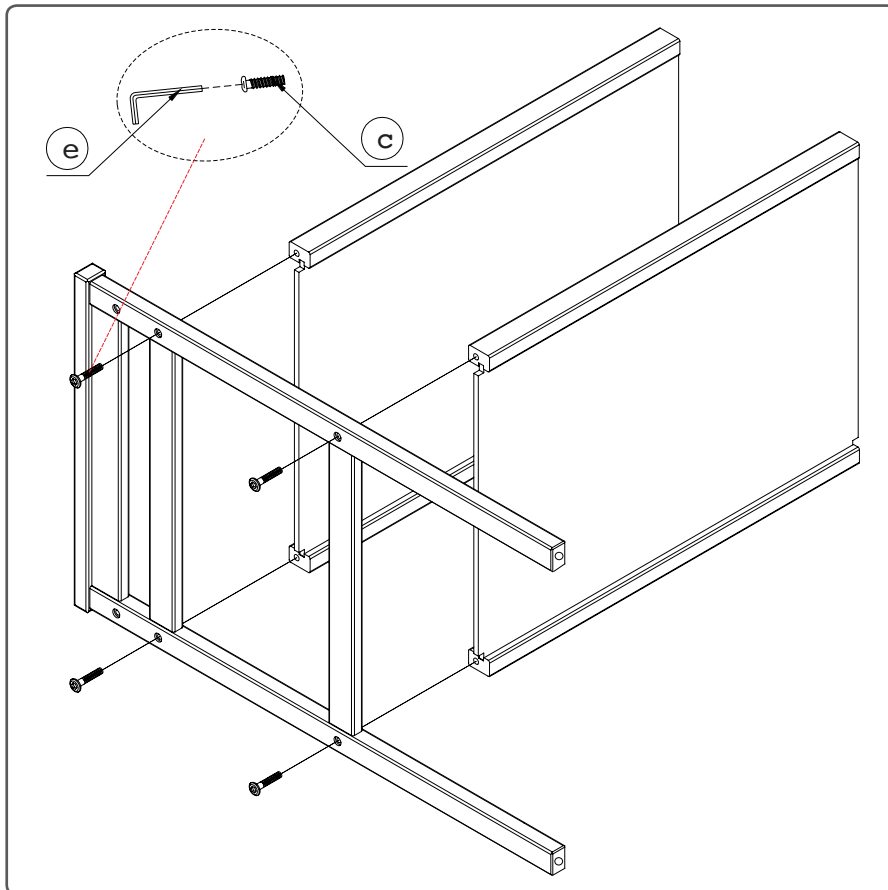

Assembly / Operating Instructions



Assembling top side rails

1. Attach both top side rails into the headboard as per the diagram by aligning the top side rail's cushion with the headboard slots.
2. Insert a bolt (c) in each end of the headboard for each top side rail. Ensure they are secure, but not tight.

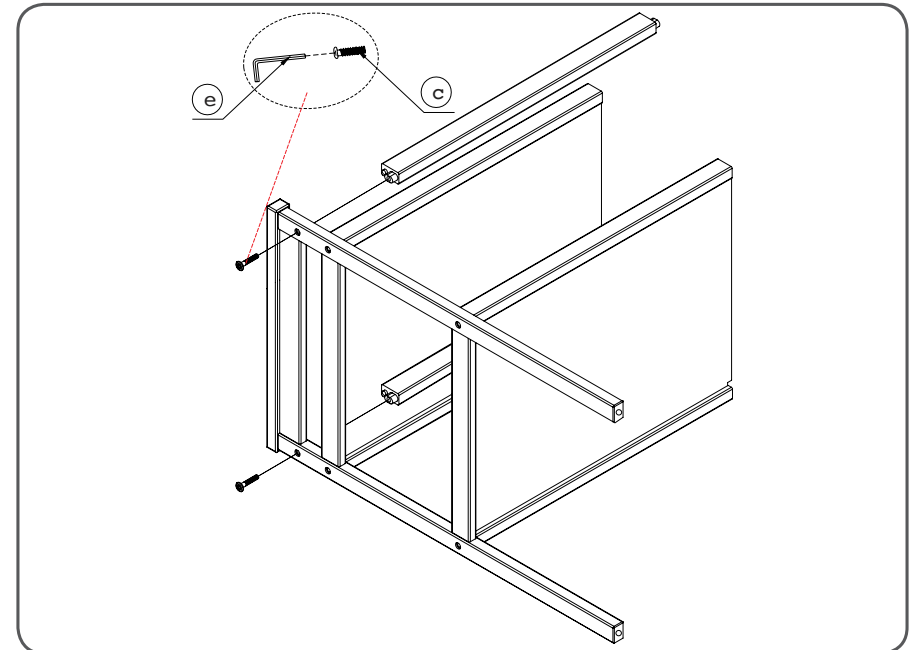

Assembly / Operating Instructions



Assembling foot end

1. Attach the foot end to the shelves and the top side of the rails by aligning the foot end to both the shelves and top side rail's grooves.
2. Insert the remaining 6 bolts (c) in foot end and ensure they are secure with the allen key (e).
3. Once all the bolts are secure, tighten all 12 bolts (c).

⚠ **WARNING: DO NOT over tighten bolts.**

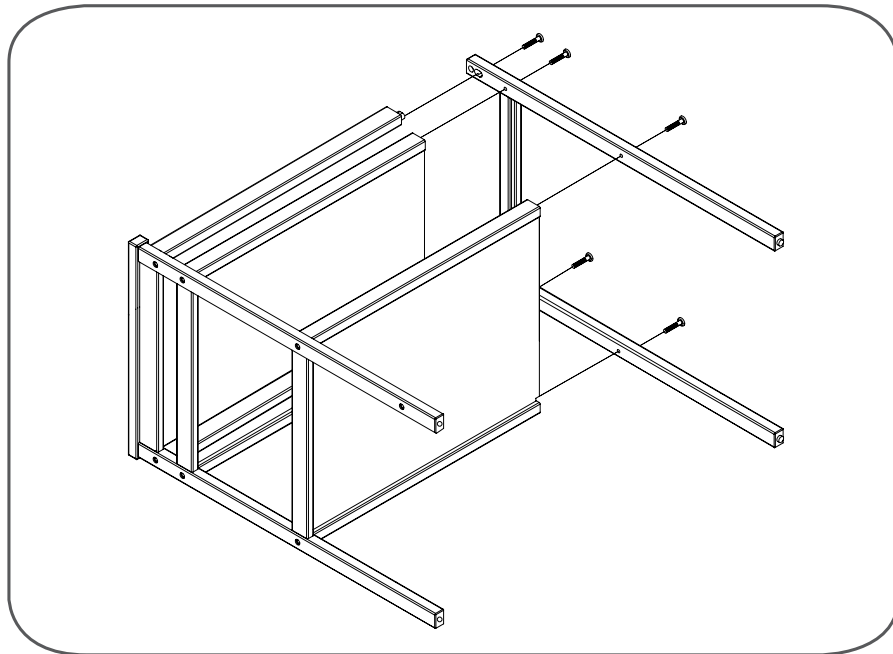

How to care for your Change Table



Cleaning

To ensure the long-lasting use of your change table, wipe down with a damp cloth and use a mild soap solution if necessary. Do not use abrasive cleaners. Always store product in a clean dry place.

Maintenance

Always check parts regularly for tightness of bolts, nuts and other fasteners – tighten or replace if required. To maintain the safety of your change table, seek prompt repairs for bent, torn, worn or broken parts. Use only those parts and accessories approved by CNP Brands.

If you have any difficulties in assembling the change table, please contact our Service Department. In Australia, contact CNP Brands on 1300 667 137, in New Zealand contact Wainhouse Distribution on 0800 567 5000.

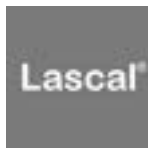

Distributed in Australia by CNP Brands, 20 Calarco Drive,
Derrimut, VIC, 3030
Customer Service 1300 667 137
W: www.cnpbrands.com.au
E: info@cnpbrands.com.au

Distributed in New Zealand by Wainhouse Distribution, 2-6 Argyle St,
Morningside, PO Box 41-014, St Lukes, Auckland, New Zealand
Customer Service: 0800 567 5000
E: helpline@wainhousedist.co.nz

