



Osmo

Cot

#091576-003



**IMPORTANT:
RETAIN FOR FUTURE REFERENCE,
READ CAREFULLY**

Read all instructions before assembly and use of the cot. Keep instructions for future use.

⚠ WARNING ⚠

ADULT ASSEMBLY REQUIRED:

DUE TO THE PRESENCE OF SMALL PARTS DURING ASSEMBLY, KEEP OUT OF REACH OF CHILDREN UNTIL ASSEMBLY IS COMPLETE.

TO PREVENT FALLS, THE MATTRESS BASE OF THIS COT SHOULD BE ADJUSTED TO THE LOWEST POSITION BEFORE THE CHILD CAN SIT UP.

RECOMMENDED MATTRESS SIZE:

690 MM WIDE X 1300 MM LONG X 100 MM-150 MM THICK.

FOLLOW THE MANUFACTURER'S ASSEMBLY INSTRUCTIONS TO ENSURE THE SAFETY FEATURES OF THE COT ARE NOT COMPROMISED.

This cot has been manufactured for one child only, with a maximum weight of **18kgs** in cot configuration. When the mattress base is assembled in the lower position, ensure the higher cot base holes are covered tightly with the filling bolts supplied. This is to prevent finger entrapment, swallowing and inhalation hazards.

ENSURE the cot is placed at a reasonable distance from curtains, blinds, heaters and power points.

ENSURE the cot is completely assembled and check that all parts are securely tightened before placing the child into the cot.

ENSURE medication, string, elastic, small toys or small items such as money etc are always kept out of the child's reach from any position in the cot.

DO NOT over tighten bolts/screws.

ENSURE that the child is clear of any moving parts when adjusting the cot.

For warranty purposes, keep your sales receipt to provide proof of purchase.

RECOMMENDED MATTRESS SIZE (SOLD SEPARATELY):

THIS COT HAS BEEN MANUFACTURED FOR USE WITH A MATTRESS WHICH MEASURES 1300MM LONG BY 690 MM WIDE AND 100-150 MM IN THICKNESS.

The width and length are specified because it is important that the gaps between the mattress and the sides and ends of the cot will not exceed 40 mm when the mattress is pushed to one side or end, and 20mm when the mattress is centred in the cot.

This is to minimise the danger of a child's limb becoming caught in the gap.

The thickness of the mattress has been specified to ensure that the depth of the cot is greater than 500 mm with the mattress base in the lower position and is greater than 300mm with the mattress base in the upper position, to minimise the risk of a child climbing or falling out of the cot.

Congratulations on your purchase of the **Childcare Osmo Cot.**

This product has been designed and developed with safety, comfort and functionality in mind. Please take the time to read this manual carefully before using this product and keep it in a safe place for future reference.

Contents

Assembly contents list

Assembly / Operating instructions

How to care for your **Childcare Osmo Cot**









Due to variations in the style and design of our products, the photographs and illustrations shown in this instruction manual are generic, therefore product fabrics, colour and design may vary from images shown. CNP Brands reserves the right to alter product specifications without notice as a result of our ongoing policy of product improvement.

Check what you have received...

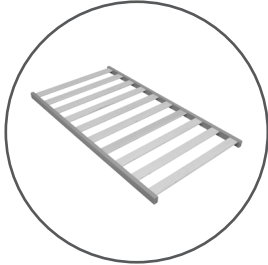
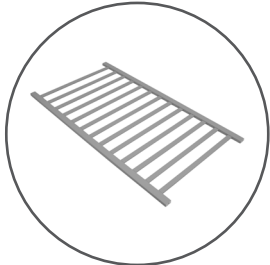
You have received **1 box**. Please check the contents of the box against the list below. If anything is missing, please contact Customer Service.

In Australia, contact **CNP Brands on 1300 667 137**, in New Zealand contact **Wainhouse Distribution on 0800 567 5000**.

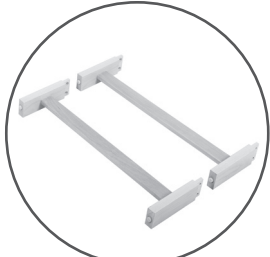
Supplied loose in box:

End Panel		x 2	Mattress Base		x 1
Side Panel		x 2	35mm Bolt		x 12
Filler Bolt and Nut (Pre-assembled)		x 4	22mm Feet Bolt		x 8
Leg Assembly		x 2	Allen Key		x 1

Recommended use with 115282-003 Inner Spring Mattress - White.

- a. It is advisable that two people assemble the cot in the room in which it is to be used.
- b. As small parts are involved in assembly, children should be kept clear of the assembly area.
- c. Dispose of all packaging material immediately after the cot is assembled.
- d. Identify all parts and components.
- e. Clear an area on the floor for assembly and place a sheet on the floor to ensure the cot is not scratched during assembly.

⚠ WARNING ⚠

DO NOT OVERTIGHTEN BOLTS. OVERTIGHTENING BOLTS CAN CAUSE PANELS TO CRACK.

To assemble Cot...

1

- 1a. Attach both End Panels to one **Side Panel** using 4 x **35mm Bolts**.
- 1b. Tighten Until Firm.

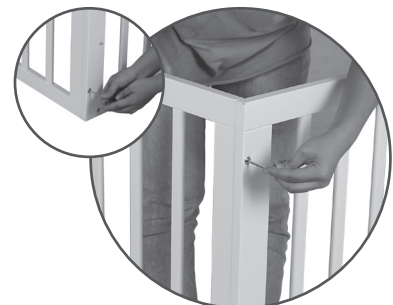

NOTE: Ensure that the bolt recesses are facing out.

2

- 2a. Cot should now resemble photo opposite.



3

- 3a. Carefully lay the cot down on the **Side Panel**.



To assemble Cot continued...

4

4a. Slide the **Mattress Base** between the **End Panels**.



⚠ WARNING ⚠

MATTRESS BASE 'THIS SIDE UP' LABEL MUST BE FACING UPWARD WHEN MATTRESS BASE IS INSTALLED

5

5a. Secure the **Mattress Base** using 4 x **35mm Bolts**.

5b. Do not tighten completely.

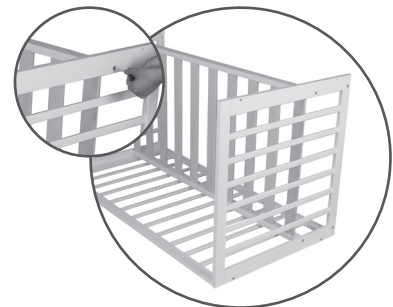

6

6a. Carefully stand the cot upright.



8

8a. Attach the remaining **Side Panel** between the **End Panels** using 4 x **35mm Bolts**.



9

9a. Tighten all bolts until firm.

9b. Do not over tighten bolts. Over tightening bolts can cause panels to crack.



To assemble Cot continued...

- 10**
- 10a. Lay Cot back down on a side panel.
 - 10b. Attach one **Leg Assembly** to the bottom of the side panel using 4 x **22mm Bolts**.
 - 10c. Repeat for second **Leg Assembly**.

NOTE: Ensure feet are angled outward when attached to the cot.

- 11**
- 11a. Carefully stand the cot upright. Check all bolts for firmness, but do not overtighten.

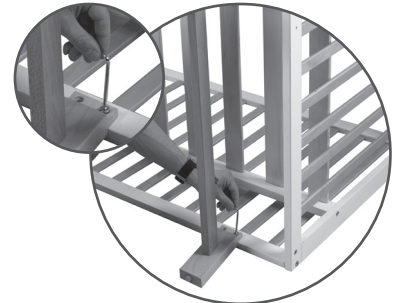

The cot is now ready for use in high base mode.

Mattress Base Heights...

Mattress Base in High Position

The base height is set for when your baby is young and cannot sit up unaided.



Mattress Base in Low Position

This is the normal position for an active baby who can sit up unaided.



To adjust Mattress Base Height...

- 1
 - 1a. Carefully lay the cot down on the **Side Panel**.
 - 1b. Remove the 4 x **Filler Bolts and Nuts** for the lower base position on the **End Panels**.

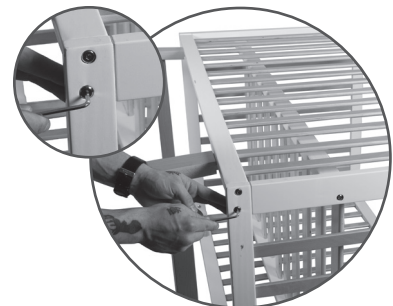

- 2
 - 2a. Remove 4 x **35mm Mattress Base Bolts**.

NOTE: Loosening the bolts of one end panel will assist in avoiding any scratches or dents to your Cot whilst sliding the mattress base down to the lower position. If end panel bolts are loosened during this process, ensure they are re-tightened after you have moved the mattress base.

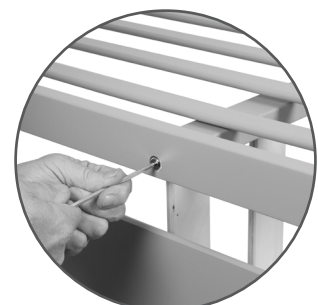

To adjust Mattress Base Height continued...

3

3a. Carefully slide the **Mattress Base** to the lower position and attach with 4 x **35mm Bolts**.

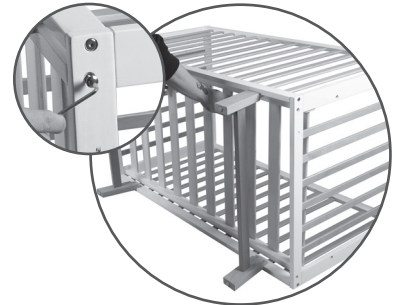

4

4a. Refit 4 x **Filler Bolts and Nuts** to the upper **Mattress Base Mounting** holes to prevent possible finger entrapment.



5

5a. Carefully stand the cot upright.



The cot is now ready for use in low base mode.



Cleaning

This product has been designed and developed with safety, comfort and functionality in mind. Please take the time to read this manual carefully before using this product and keep it in a safe place for future reference.

To ensure the long-lasting use of your cot, wipe down with a damp cloth and use a mild soap solution if necessary. Do not use abrasive cleaners. Always store product in a clean dry place.

Maintenance

Always check parts regularly for tightness of screws, nuts and other fasteners – tighten or replace if required. To maintain the safety of your cot, seek prompt repairs for bent, torn, worn or broken parts. Use only those parts and accessories approved by **CNP Brands**.

If you have any difficulties in assembling the stroller, please contact our Service Department.

In Australia, contact **CNP Brands** on **1300 667 137**, in **New Zealand** contact **Wainhouse Distribution** on **0800 567 5000**.

Warranty

For all warranty terms and conditions, please visit cnpbrands.com.au



CNP BRANDS[®]

CHILDCARE NURSERY PRODUCTS

About CNP Brands

Currently, **CNP Brands** boasts one of the most diverse brand portfolios with a combination of company owned brands and distribution agreements.

Our own brands, including **Childcare**, have gone from strength to strength in recent years. **Childcare**, and our premium brand **bebe care**, demonstrate our commitment to quality and continuing investment in product development.





CNP BRANDS®

CHILDCARE NURSERY PRODUCTS



Distributed in Australia by CNP Brands
82 Maribyrnong Street, Footscray, VIC, 3011
Customer Service 1300 667 137

W: www.cnpbrands.com.au
E: info@cnpbrands.com.au
F: www.facebook.com/CNPBrands
I: [@cnp_baby](https://www.instagram.com/cnp_baby)

Distributed in New Zealand by Wainhouse
Distribution
2-6 Argyle St, Morningside,
PO Box 41-014,
St Lukes, Auckland, New Zealand
Customer Service: 0800 567 5000

E: helpline@wainhousedist.co.nz

