



childcare

Osmo

Breathable Bedside Sleeper "Beech"

Model #036343-136



**IMPORTANT:
RETAIN FOR FUTURE REFERENCE,
READ CAREFULLY**

**Read all instructions before assembly and use of the bedside sleeper.
Keep instructions for future use.**

⚠ WARNING ⚠

**NEVER LEAVE THE CHILD UNATTENDED IN THE BEDSIDE SLEEPER.
IT IS DANGEROUS TO PLACE THE PRODUCT ON A RAISED SURFACE SUCH AS A TABLE.
DO NOT USE THE PRODUCT IF ANY PART IS BROKEN, TORN, OR MISSING.
ONLY AN ADULT SHOULD ASSEMBLE, FOLD AND UNFOLD THE BEDSIDE SLEEPER.
BEFORE ASSEMBLY, CHECK THAT THE PRODUCT AND ALL OF IT'S COMPONENTS HAVE NOT BEEN DAMAGED DURING TRANSPORTATION. SHOULD ANY PART BE DAMAGED, DO NOT USE AND KEEP OUT OF REACH OF CHILDREN.
ENSURE USERS OF THIS PRODUCT ARE KNOWLEDGEABLE ON IT'S CORRECT OPERATION.
DO NOT POSITION THE PRODUCT NEAR WALLS AND OBSTACLES TO PREVENT ENTRAPMENT.
DO NOT ADJUST THE PRODUCT WITH THE CHILD INSIDE.
DO NOT MOVE THE PRODUCT WITH THE CHILD INSIDE.
DO NOT USE THE PRODUCT WITH MORE THAN ONE CHILD AT A TIME.**

This product is intended for use for babies aged between **0 and 5 months**, weighing up to a **maximum of 9kg**. When a child is able to sit, kneel or to pull itself up, the product should not be used anymore for this child. Before use in 'bedside sleeper' mode (fixed to the bed), make sure the product is securely anchored and positioned.

When the product is used in 'bedside sleeper' mode (fixed to the bed), make sure the connection belts are hooked and tensioned properly, before laying child in the sleeper. The product must be secured to the parent's mattress and no gaps between the product and the adult's mattress must be present.

DO NOT use the sleeper without the support frame. Keep the fastening belts out of reach of children.

The thickness of the uncompressed mattress shall not exceed 25mm. The upper surface of the non compressed mattress must be at least 191 mm lower than the upper surface of the lowest side of the bedside sleeper.

If you purchase a mattress separately, ensure that it is suitable for the product.

DO NOT leave any object inside the product that could reduce it's depth.

Be aware of the risk of open fires and other sources of strong heat, such as electric bar heaters, gas fires etc.

The product is ready for use only when all locking mechanisms are engaged. Check carefully that these are engaged before use.

Failure to follow these warnings and instructions could result in serious injury or death.

NEVER use the bedside sleeper bassinet in bedside sleeper position without the anchor plate attached and locked as shown. Failure to use this anchoring system could result in serious injury or death to the infant. Make sure all straps are secured and tight. Check straps before each use.

SUFFOCATION HAZARD: Discard all packing materials immediately after opening. Plastic bags and ties may cause suffocation or choking.

FALL HAZARD: To help prevent falls, do not use this product when infant begins to push up on hands and knees or has reached manufacturer's recommended maximum weight of 9kgs, whichever comes first.

⚠ WARNING ⚠

SUFFOCATION HAZARD - INFANTS HAVE SUFFOCATED IN GAPS BETWEEN EXTRA PADDING AND SIDE OF BASSINET/CRADLE AND ON SOFT BEDDING.
USE ONLY THE PAD PROVIDED BY MANUFACTURER.
NEVER ADD A PILLOW, COMFORTER OR ANOTHER MATTRESS FOR PADDING.

If a sheet is used with the pad, use only the one provided by CNP Brands.

To reduce the risk of SIDS, paediatricians recommend healthy infants be placed on their backs to sleep, unless otherwise advised by your physician.

A bedside sleeper is designed to provide a sleeping area for an infant until he or she begins to push up on hands and knees or approximately 5 months of age. Move your child to another sleeping product when your child reaches this stage.

STRANGULATION/SUFFOCATION HAZARD: The top edge of the lowering bar must be level with or below the top of the adult mattress when used as the bedside sleeper. The level of the bedside sleeper bassinet mattress must be a minimum of 10cm below the top edge of the lowering bar. NEVER raise the level of the bedside sleeper bassinet mattress.

NEVER use plastic shipping bags or other plastic film as mattress covers not sold and intended for that purpose. They can cause suffocation.

Make sure all straps are secured and tight when used in the bedside sleeper position. Tighten straps periodically.

⚠ WARNING ⚠

ENTRAPMENT HAZARD - TO PREVENT DEATH FROM ENTRAPMENT, BEDSIDE SLEEPER MUST BE PROPERLY SECURED TO ADULT BED USING THE ATTACHMENT SYSTEM

There must be no more than 1/2 inch (13mm) gap between bedside sleeper and adult bed.

Check tightness before each use by pulling bedside sleeper in a direction away from adult bed.

If gap exceeds 1/2 inch (13mm) **DO NOT** use product. **DO NOT** fill the gap with pillows, blankets or other items that are suffocation hazards.

ALWAYS read and follow assembly instructions for each product use mode (bedside sleeper, bassinet).

ALWAYS use ALL required parts for each use mode. Check instruction manual for a list of required parts. Periodically check product for loose, damaged, or missing parts.

The anchor plate and straps assembly must always be used in bedside sleeper mode.

NEVER use this product if there are any loose or missing fasteners, loose joints, broken parts, or torn mesh/fabric. Check before assembly and periodically during use. Contact CNP Brands for replacement parts. Never substitute parts.

Assemble product according to manufacturer's instructions for ANY use mode - bedside sleeper as well as the bassinet.

To avoid death from the infant's neck being caught on the top rail on the side that is next to the adult bed, the top rail must be no higher than the adult bed mattress.

NEVER permit bedding from the adult bed to extend into the bedtime sleeper.

NEVER leave your infant in the product without the TOP HORIZONTAL RAIL installed in the upper most position, unless securely attached to the adult bed.

Failure to use this securing system will allow the bedside sleeper to move away from the adult bed and could result in the infant falling out of the bedside sleeper bedside bassinet.

STRANGULATION HAZARD: When anchor plate and strap assembly are not in use, store in a safe place not accessible to children.

DO NOT place product near a window where cords from blinds or drapes may strangle a child.

Keep the bassinet away from stoves, heaters, camp fires and other hazards.

DO NOT allow children to climb or play on or under unit in any configuration.

FALL HAZARD: Remove infant from the bedside sleeper before starting any conversions.

Always make sure all top and bottom rails are securely locked, in all configurations, before putting an infant child into the unit.

To prevent serious or fatal injury from falls always keep child within arm's reach.

NEVER leave your child unattended.

Strings can cause strangulation! **DO NOT** place items with a string around a child's neck, such as hood strings over a bassinet or cradle or attach strings to toys.

The bedside sleeper is designed for use only with adult beds that are between 55-66cm from floor to top of adult mattress.

Congratulations on your purchase of the **Osmo Breathable Bedside Sleeper - Beech.**

This product has been designed and developed with safety, comfort and functionality in mind. Please take the time to read this manual carefully before using this product and keep it in a safe place for future reference.

Contents

Assembly contents list

Assembly / Operating instructions

How to care for your **Osmo Breathable Bedside Sleeper**

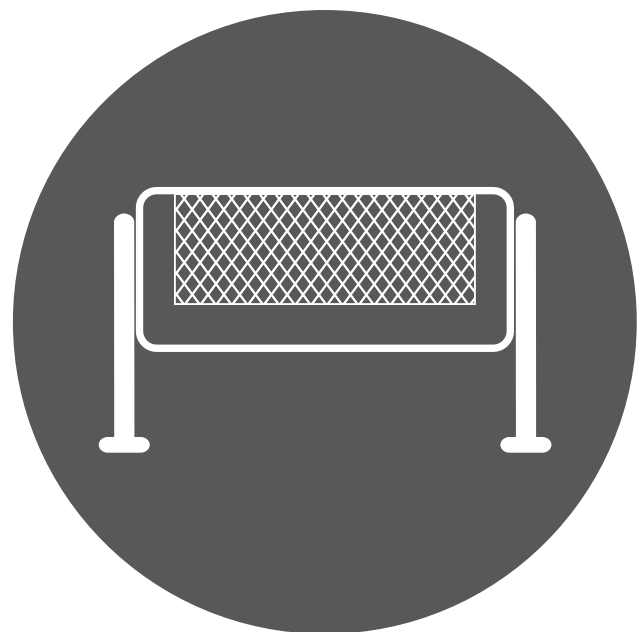





Due to variations in the style and design of our products, the photographs and illustrations shown in this instruction manual are generic, therefore product fabrics, colour and design may vary from images shown. CNP Brands reserves the right to alter product specifications without notice as a result of our ongoing policy of product improvement.

Check what you have received...

You have received **1 box**. Please check the contents of the box against the list below. If anything is missing, please contact Customer Service.

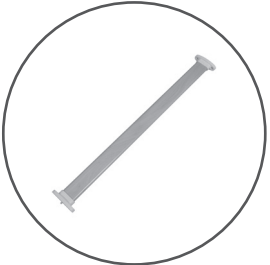
In Australia, contact **CNP Brands on 1300 667 137**, in New Zealand contact **Wainhouse Distribution on 0800 567 5000**.

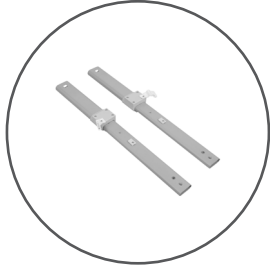
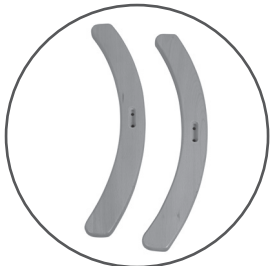
Supplied loose in box:

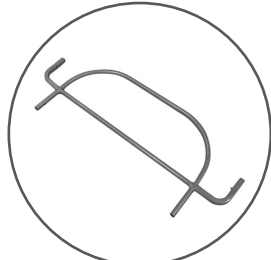
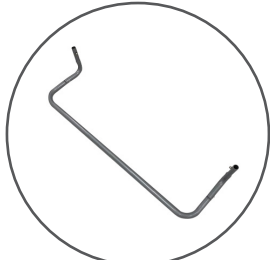
Top frame, liner, side support legs and mattress with removable cover		x 1	Lower Crossbar		x 1
Carry Bag		x 1	Side Support Frame		x 2
Foot Board Panels		x 2	Fixing belts with anchor plates		x 2
Middle Support Frame		x 1	Front Support Bar		x 1

There are no accessories recommended for use with this Childcare Bedside Sleeper.

Supplied loose in box continued:

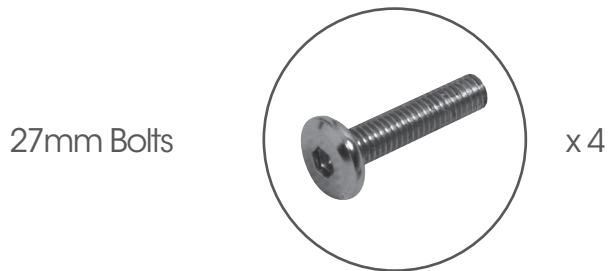
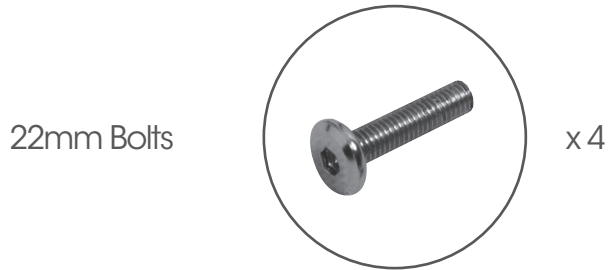

Fully assembled product:

- A: Side Support Frame
- B: Mattress with removable cover
- C: Fixing Belt with anchor plate
- D: Top Frame & Liner

- E: Lower Crossbar
- F: Foot Board Panel
- G: Middle Support Frame & Front Support Bar



To assemble Frame & Bedside Sleeper Liner...

1

- 1a. Lay bedside sleeper (top frame, liner and support legs) face down on a soft clean surface.



2

- 2a. Connect the **Lower Crossbar** to each leg using 2 x **22mm Bolts** on each end.

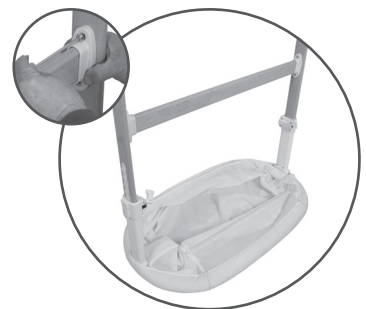

3

- 3a. Insert one **Foot Board Panel** onto the bottom of the side support leg and secure using 2 x **27mm Bolts**.
3b. Repeat for other side support leg.



4

- 4a. Slide the **Middle Support Frame** ends into the openings in the height adjuster.
4b. Push in to secure.



To assemble Frame & Bedside Sleeper Liner continued...

5

- 5a. Stand the bedside sleeper upright.
- 5b. Attach **Front Support Bar** to front of **Middle Support Frame** via push pins.
- 5c. Pull front flap over the **Front Support Bar**.
- 5d. Secure front flap and bedside sleeper liner to frame via 7 Velcro tabs located underneath the bedside sleeper.

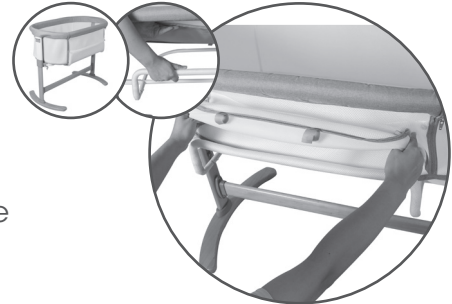

To adjust the height of Bedside Sleeper...

1

- 1a. The sleeper can be adjusted into 5 different height positions.

2

- 2a. Adjust the height of the sleeper by lifting the adjustment levers on both sides of the sleeper and lowering or raising the sleeper to desired position.
- 2b. Release adjustment levers to lock into place.



ANTI REFLUX FEATURE! To help with any reflux issues, you can raise the head end of the bedside sleeper to be 1 or 2 settings higher than the foot end. Your baby should still sleep on its back as per normal.

To fix to bed in Bedside Sleeper mode...

1

1a. Unzip the front panel on both sides.



2

2a. Slide the bar lever back and lift on both sides.

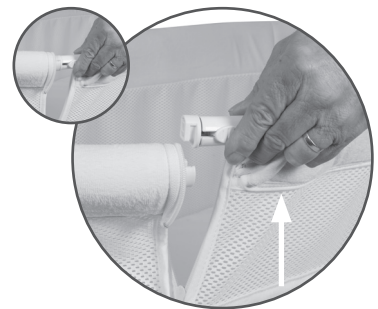

3

3a. Roll bar and unzipped front panel down.
3b. Secure with elastic tabs.

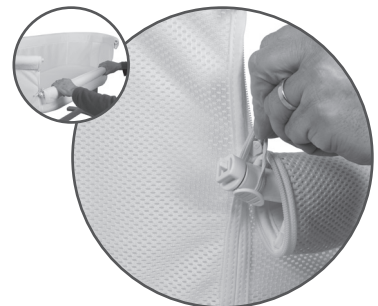

4

4a. Clip the fixing belts to the underside of the metal frame.

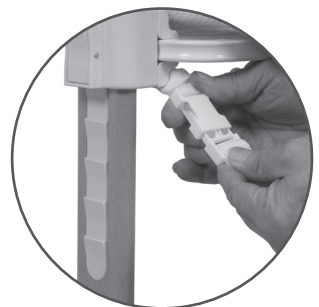

To fix to bed in Bedside Sleeper mode continued...

5

- 5a. Move the sleeper close to the parent's bed and check the height of the sleeper compared with the mattress on the bed.
- 5b. The side support of the sleeper should always be placed close to the parent's mattress and the mattress should always be aligned with the height of the side support for restraint of the sleeper.

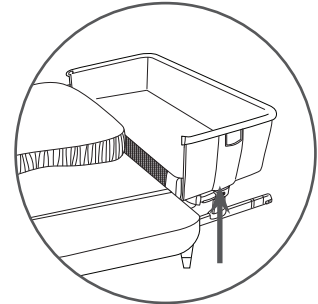

6

- 6a. In order to fix the Sleeper to the parent's bed in bedside sleeping mode, use the attached pair of fixing belts provided.
- 6b. Slide the straps between the top mattress and the base using a back and forth 'sawing' motion and at the same time pulling downward until the straps and anchor plates are in the desired position.

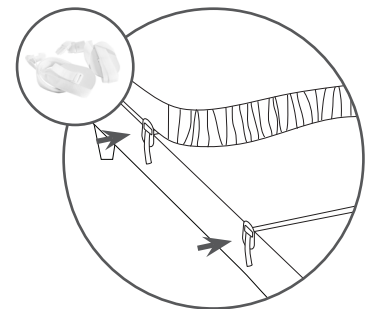

7

- 7a. The anchor plates should appear like the opposite picture once they are assembled between the mattress and the base.

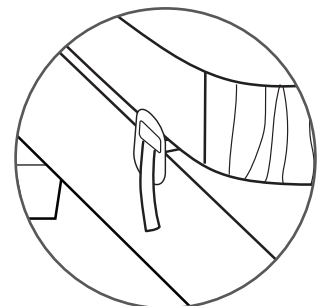

CAUTION! Ensure the fixing belts are straight

8

- 8a. Tighten the loop by pulling the belts firmly.
- 8b. Adjust the belts separately until the sleeper is firmly in contact with the parent's mattress.
- 8c. Store any excess of belts between the mattress and the bed base.

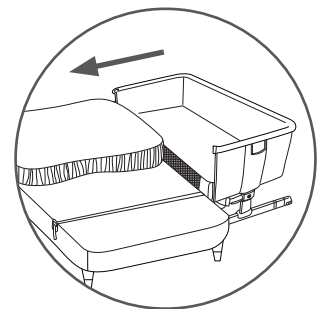

To fix to bed in Bedside Sleeper mode continued...

⚠ WARNING ⚠

Before every use always check to make sure there is no space between the parent's mattress and the side of the sleeper.

If there is, pull the belts firmly to tighten until there's no space and the permitted condition of use has been restored.

Use of product is only permitted with beds and/or mattresses with straight sides, use of the product with round mattress and or water bed is not permitted.

When the product is used in the bedside sleeping mode, it should always be fitted to the long side of access to the bed, do not fix the product to the head or bottom of the bed.

Mattress, Boxsprings & Frame aligned

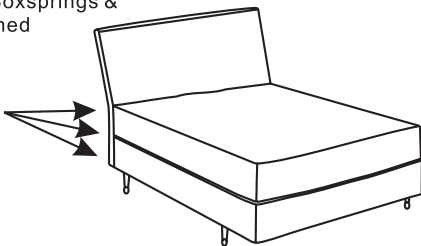

ACCEPTABLE BED FRAME IN-LINE

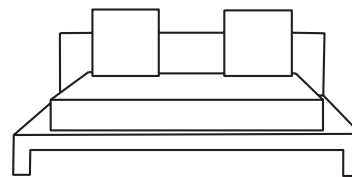

Frame Extended

UNACCEPTABLE BED, MATTRESS,BOXSPRING&FRAME NOT IN-LINE

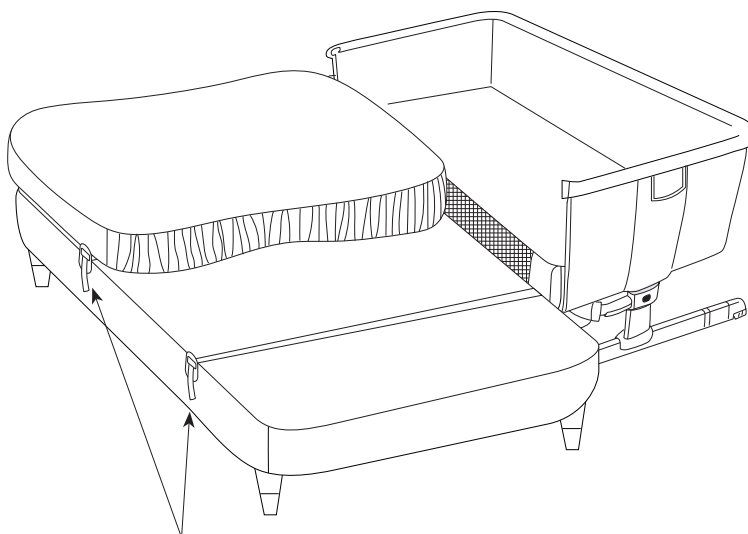

Never use the Bedside Sleeper in bedside sleeping position without the anchor plate. Ensure the plate is securely attached to the adult bed.

To assemble free standing Bassinet Mode...

1

- 1a. Release the rolled up elastic tabs and roll out front panel.
- 1b. Line up the bar of the support frame as shown in the image.

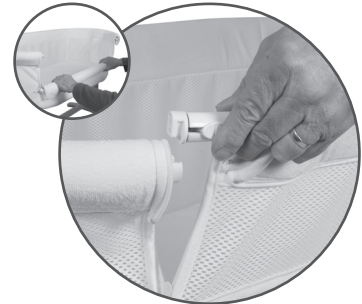

2

- 2a. Locate the slots on the bar end and slide the bar into position, pushing down to lock.
- 2b. Zip up both sides of sleeper.



To remove Lining...

1

- 1a. Unfasten all Velcro tabs from the underside of the sleeper.

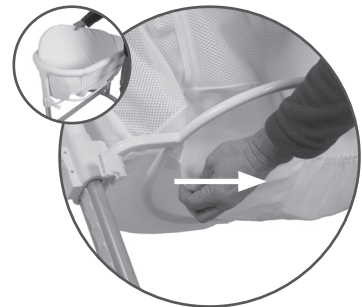

2

- 2a. Locate the zip on the rear of bassinet liner and unzip.
- 2b. Remove front panel bar.



To remove Lining (continued)...

3

- 3a. Gently remove the lining from the top frame by sliding it off the top frame tubes on both sides.



Cleaning

This product has been designed and developed with safety, comfort and functionality in mind. Please take the time to read this manual carefully before using this product and keep it in a safe place for future reference.

To ensure the long-lasting use of your Sleeper, do not use solvents, abrasives or aggressive cleaning products. After each wash check the resistance of the fabric and the stitching. For washing of the fabric, carefully comply with instructions indicated on the label (listed below).



Hand wash in cold water

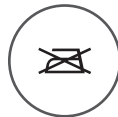

DO NOT iron



DO NOT bleach

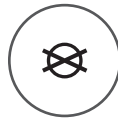

DO NOT dry clean



DO NOT tumble dry

Maintenance

Always check parts regularly for tightness of screws, nuts and other fasteners – tighten or replace if required. The Sleeper and the mattress have a resistant fabric cover which is completely removable and washable. The removal of the fabric should be carried out by an adult only. On a regular basis check the condition of the product and presence of any possible damage. In the case of damage do not use and keep it out of the reach of children. To maintain the safety of your Sleeper seek prompt repairs for bent, torn, worn or broken parts. Use only those parts and accessories approved by **CNP Brands**.

If you have any difficulties in assembling the Sleeper, please contact our Service Department.

In Australia, contact **CNP Brands on 1300 667 137**, in New Zealand contact **Wainhouse Distribution on 0800 567 5000**.



CNP BRANDS

CHILDCARE NURSERY PRODUCTS | EST. 1899



Distributed in Australia by CNP Brands
82 Maribyrnong Street, Footscray, VIC, 3011
Customer Service 1300 667 137

W: www.cnpbrands.com.au
E: info@cnpbrands.com.au
F: www.facebook.com/CNPBrands
I: @cnp_baby

Distributed in New Zealand by Wainhouse
Distribution
2-6 Argyle St, Morningside,
PO Box 41-014,
St Lukes, Auckland, New Zealand
Customer Service: 0800 567 5000

E: helpline@wainhousedist.co.nz

