

OUTDOOR LIVING SUITE



(WITH CUSTOMER-PROVIDED STONE TOP)
INSTALLATION INSTRUCTIONS
GES08, GESB08, GES12, GESB12,
GESP12, GESBP12, GESK12, GESBK12

IMPORTANT - READ ALL INSTRUCTIONS BEFORE YOU BEGIN

THE INSTALLATION HEREIN SHOULD BE PERFORMED BY A QUALIFIED SERVICE TECHNICIAN OR PROFESSIONAL OUTDOOR EQUIPMENT INSTALLER. MANY COMPONENTS ARE HEAVY AND REQUIRE 2 OR 3 PERSONS TO UN-PACK AND SETUP THIS SUITE. FAILURE TO DO SO MAY RESULT IN PERSONAL INJURY.

THE ELECTRICAL COMPONENTS SUPPLIED WITH THIS SUITE MUST BE INSTALLED BY A LICENSED ELECTRICIAN AND CONNECTED IN ACCORDANCE WITH LOCAL CODES. THE SUITE SHOULD BE CONNECTED TO A DEDICATED CIRCUIT BREAKER. ALL OUTLETS SUPPLIED WITH THIS SUITE ARE GROUND FAULT CIRCUIT INTERRUPTER OUTLETS AND MUST BE PROPERLY INSTALLED AND GROUNDED BY A LICENSED ELECTRICIAN TO GUARANTEE SAFE AND RELIABLE OPERATION.

SOME PARTS INSIDE THE SUITE HAVE SHARP EDGES. CARE MUST BE TAKEN WHEN HANDLING THE VARIOUS COMPONENTS TO AVOID PERSONAL INJURY. WEAR GLOVES WHEN HANDLING.

TOOLS REQUIRED:

- Work gloves
- Safety glasses
- Power drill with masonry bits
- Concrete / masonry anchors & hardware,
- Coated or stainless steel wood screws (for securing plywood sub-structure)
- Flat and Phillips screwdrivers
- Socket wrench with 7/16" & 9/16" sockets and short extensions
- Combination wrenches of 7/16" & 9/16" sizes
- Level

AFTER INSTALLATION OF YOUR GRILL AND OTHER GAS-FIRED EQUIPMENT IN THIS SUITE, READ THE MANUAL(S) PROVIDED WITH THOSE PRODUCTS CAREFULLY AND COMPLETELY BEFORE USING YOUR GRILL TO REDUCE THE RISK OF FIRE, BURN HAZARD, OR OTHER INJURY. KEEP THIS MANUAL FOR FUTURE REFERENCE.

⚠ WARNING IF THE INFORMATION IN THE GAS-FIRED APPLIANCE MANUALS ARE NOT FOLLOWED EXACTLY, A FIRE OR EXPLOSION MAY RESULT CAUSING PROPERTY DAMAGE, PERSONAL INJURY, OR DEATH.

⚠ WARNING Flammable Gas - disconnect all propane or natural gas supplies to this unit before servicing.

⚠ WARNING Electrical Parts & Components – disconnect all power supplies and batteries before servicing.



SUITE MODELS WITH CUSTOMER-PROVIDED TOP

Below are representations of Hestan Outdoor Living Suites covered in this manual.

EN



STONE TOP NOT INCLUDED

Suite GES08 shown with:
 GABR36 Built-In Gas Grill
 ABG122 Double Side Burner
 AGAD36 Double Access Doors
 GRSR24 Outdoor Fridge
 ALL ITEMS PURCHASED SEPARATELY

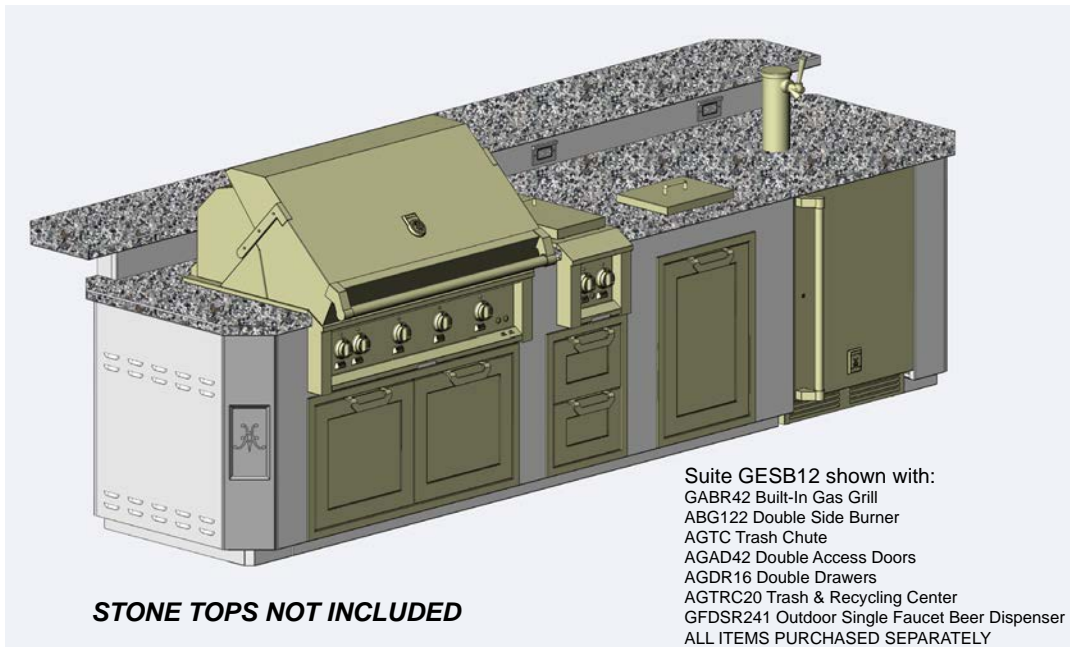

STONE TOPS NOT INCLUDED

Suite GESB12 shown with:
 GABR42 Built-In Gas Grill
 ABG122 Double Side Burner
 AGTC Trash Chute
 AGAD42 Double Access Doors
 AGDR16 Double Drawers
 AGTRC20 Trash & Recycling Center
 GFDSR241 Outdoor Single Faucet Beer Dispenser
 ALL ITEMS PURCHASED SEPARATELY

HESTAN OUTDOOR LIVING SUITES	
MODEL #	DESCRIPTION
GES08	GRILL, OUTDOOR LIVING SUITE, CUSTOMER-PROVIDED COUNTERTOP, 8 FOOT
GESB08	GRILL, OUTDOOR LIVING SUITE, CUSTOMER-PROVIDED COUNTERTOP & BAR, 8 FOOT
GES12	GRILL, OUTDOOR LIVING SUITE, CUSTOMER-PROVIDED COUNTERTOP, 12 FOOT
GESB12	GRILL, OUTDOOR LIVING SUITE, CUSTOMER-PROVIDED COUNTERTOP & BAR, 12 FOOT
GESP12	GRILL, OUTDOOR LIVING SUITE, CUSTOMER-PROVIDED COUNTERTOP, POWER BURNER, 12 FOOT
GESBP12	GRILL, OUTDOOR LIVING SUITE, CUSTOMER-PROVIDED COUNTERTOP & BAR, POWER BURNER, 12 FOOT
GESK12	GRILL, OUTDOOR LIVING SUITE, CUSTOMER-PROVIDED COUNTERTOP, KAMADO, 12 FOOT
GESBK12	GRILL, OUTDOOR LIVING SUITE, CUSTOMER-PROVIDED COUNTERTOP & BAR, KAMADO, 12 FOOT

LOCATING THE SUITE



EN

LOCATION

When determining a suitable location for your grill and suite, take into account concerns such as exposure to wind, rain, sprinklers, proximity to traffic paths, and keeping any gas supply line runs as short as possible.

Locate the grill only in a well-ventilated area. Never locate the grill in a building, garage, breezeway, shed or other such enclosed areas without an approved ventilation system. Never locate the grill over, under, or next to unprotected combustible construction.

AIRFLOW / WINDY AREAS

During heavy use, the grill will produce a lot of heat and smoke. The grill is designed to take in cool air at the front control panel area, and send the combustion products and smoke out the exhaust gap at the rear of the hood. IT IS IMPORTANT TO MAINTAIN THIS FLOW AT ALL TIMES.

Using the grill in windy areas can disrupt the proper flow and cause damage to your grill, or result in burn hazards to the user. Initial indications of this situation are very hot control knobs. Using an oven mitt or other protection, and while keeping your face away, immediately open the hood to release the built up heat inside the grill. Turn down the burners to a lower setting. It is very important that the suite & grill is oriented so the prevailing wind is toward the front of the grill as seen below in Fig. 1.

For built-in grill installations which consistently receive wind at the rear of the grill, a Wind Screen accessory is available from Hestan. Contact your Hestan dealer for details.



Damage caused from use in windy conditions, such as melted knobs and/or wiring, discoloration of the control panel, etc., is excluded from warranty coverage.

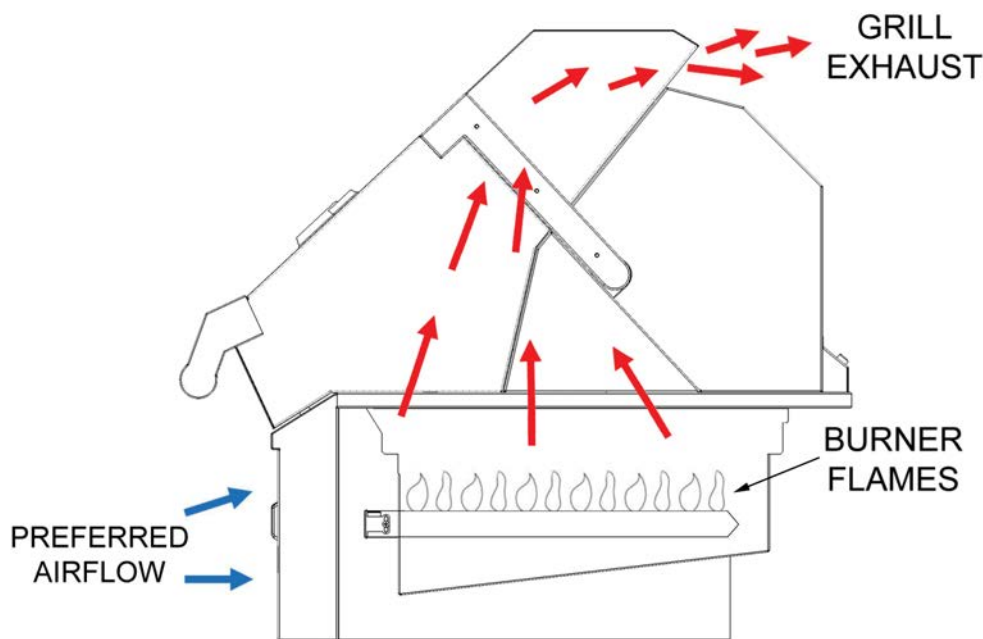

Figure 1

The Hestan Outdoor Living suite features ventilation openings (louvers) on each end. These openings must be clear to avoid accumulation of gas should there be a leak. These openings are further described later in this manual.



CURB INSTALLATION

1. The Hestan Outdoor Living Suite must be located on a flat and level concrete or masonry patio surface, not on direct soil. A licensed plumber and electrician should run their service lines to the suite area prior to installation of the curb, in accordance with local codes. See dimensions below for recommended location. See ELECTRICAL ITEMS section of this manual for details. The gas line to the suite will require a shut-off that is easily accessible. Local codes may also require a tracer wire be buried alongside the gas line for underground detection. See the GAS CONNECTIONS section of this manual, and the appliance manual(s) for more details.

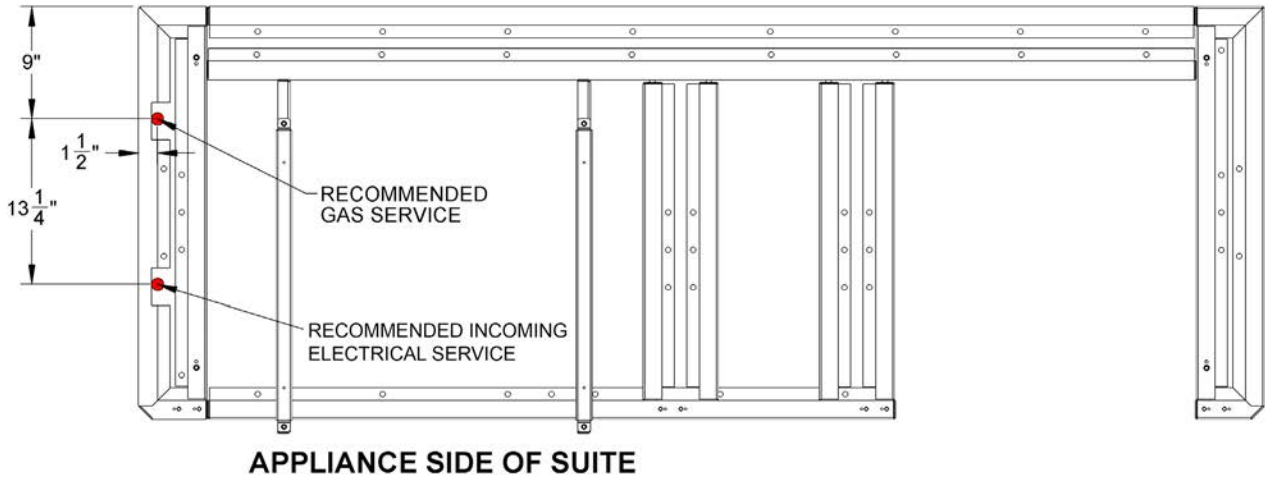

CURB TOP VIEW SERVICE LOCATIONS

2. The curb should be as level as possible and **permanently** anchored to the patio surface using stainless steel masonry anchors & bolts (not included). If you choose not to permanently anchor your suite, be sure you have moved it to its final location. Also be aware that the suites featuring a bar are prone to tipping over unless the curb is anchored to the floor surface. The Outdoor Living Suite is very heavy and difficult to move once assembly is complete and all equipment has been installed. (8 foot Outdoor Living Suite curb shown)

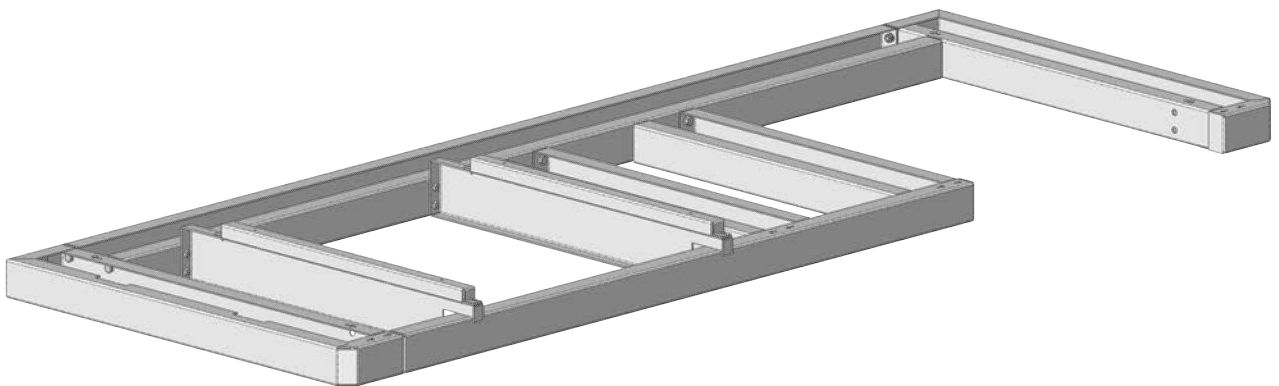

BACK AND SUPPORT WALL ASSEMBLY



- Use 2 each 3/8-16 x 5/8" long hex bolts to align and attach the back wall to the curb. Be careful the back wall does not tip over if the curb was not anchored down. Tighten all bolts.

EN

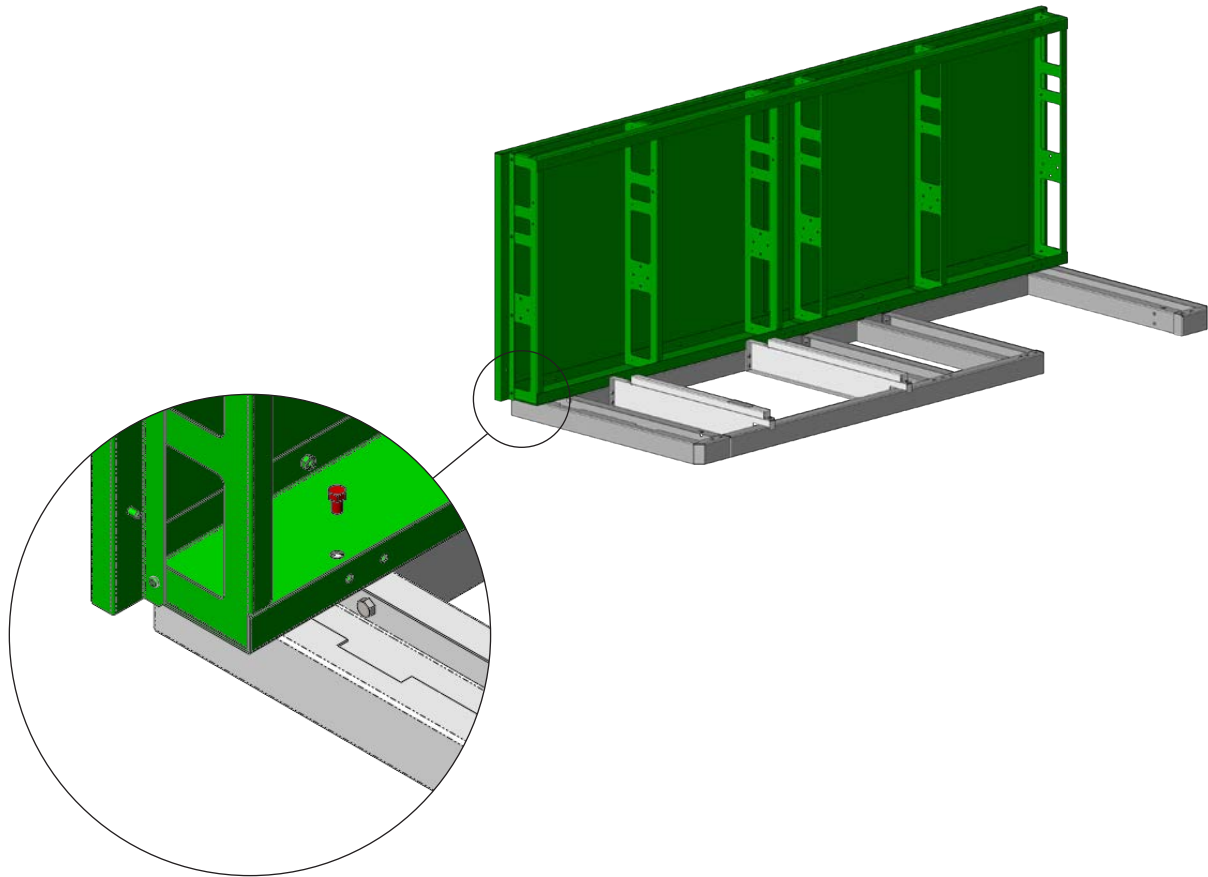



BACK AND SUPPORT WALL ASSEMBLY *(continued)*

4. Attach support wall #1 to curb assembly and back wall as shown using 6 each 1/4-20 x 1/2" hex bolts and hex nuts where needed. Do not fully tighten bolts yet. Route the main electrical box as described below and attach using 2 each 1/4" hex nuts.

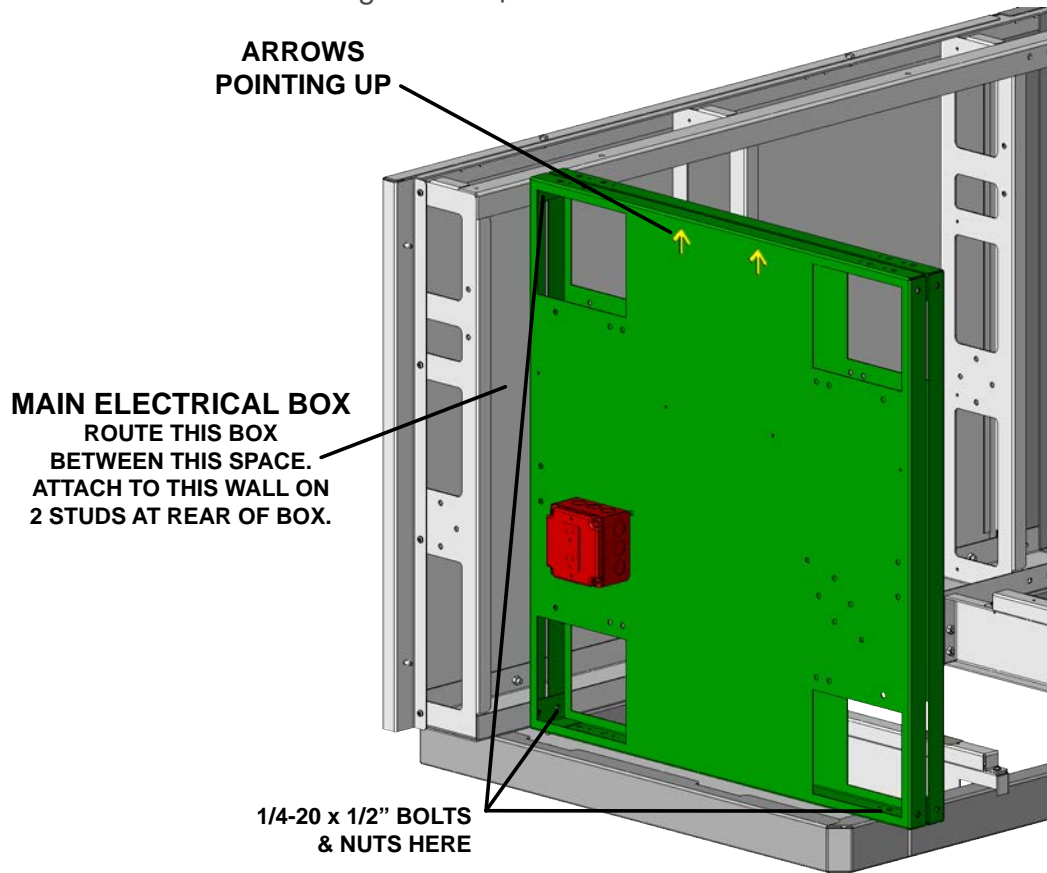

5. Install remaining support walls as you did in step 4. Each wall is numbered and has a corresponding number on the curb and/or rear wall for ease of locating. (8 foot Outdoor Living Suite shown)
Do not fully tighten bolts yet. Note all arrows are pointing up.

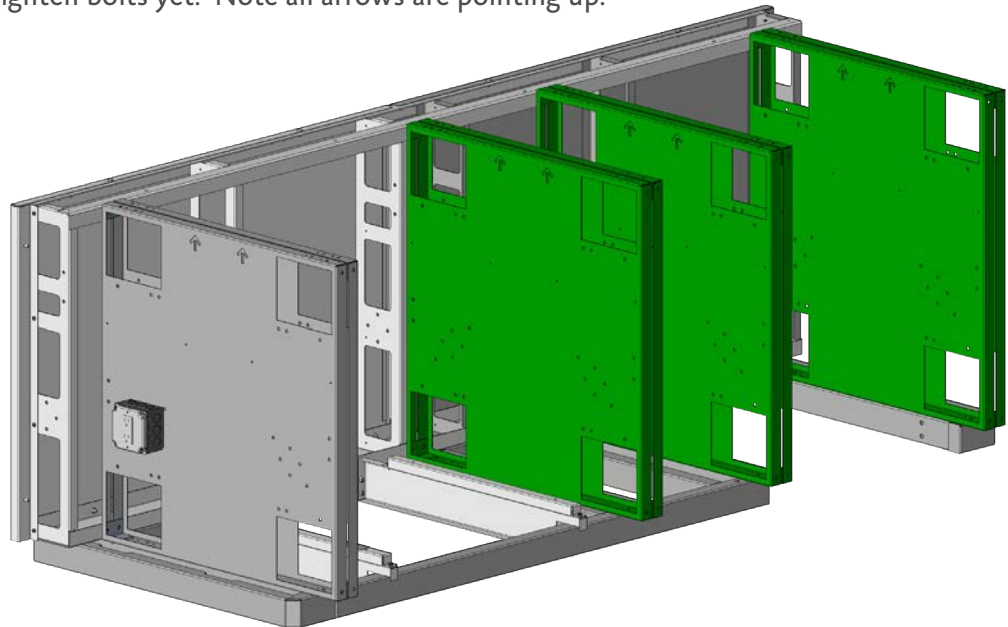

INSTALL CORNER ASSEMBLY



EN

6. Install corner assembly brackets as shown using 1/4-20 x 1/2" long hex bolts and hex nuts where needed. For suites with Bar Top, install 4 brackets on each side.

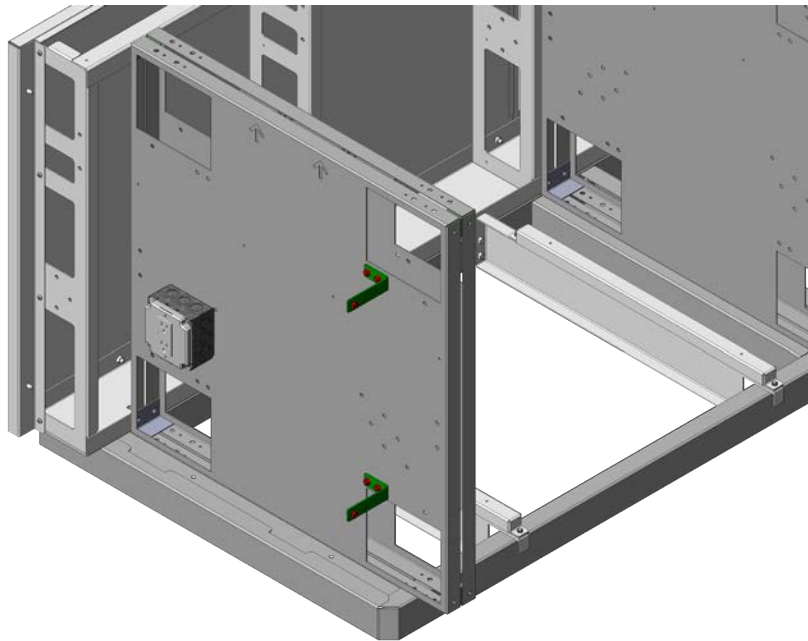

7. Install 2 corner assemblies (4 assemblies for suites with Bar Top). Use 1/4-20 x 1/2" long hex bolts and hex nuts where needed. **Do not tighten until lift-off panels have been checked for proper fit (see Step 13).**

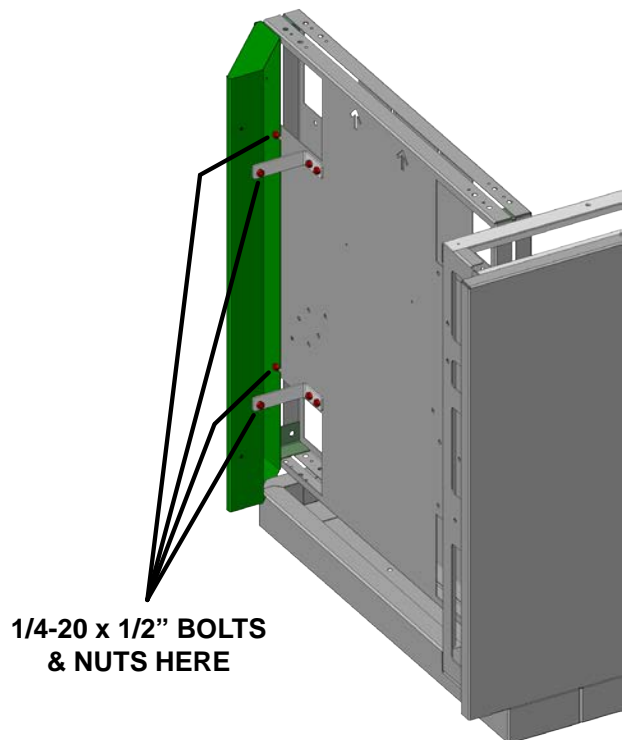
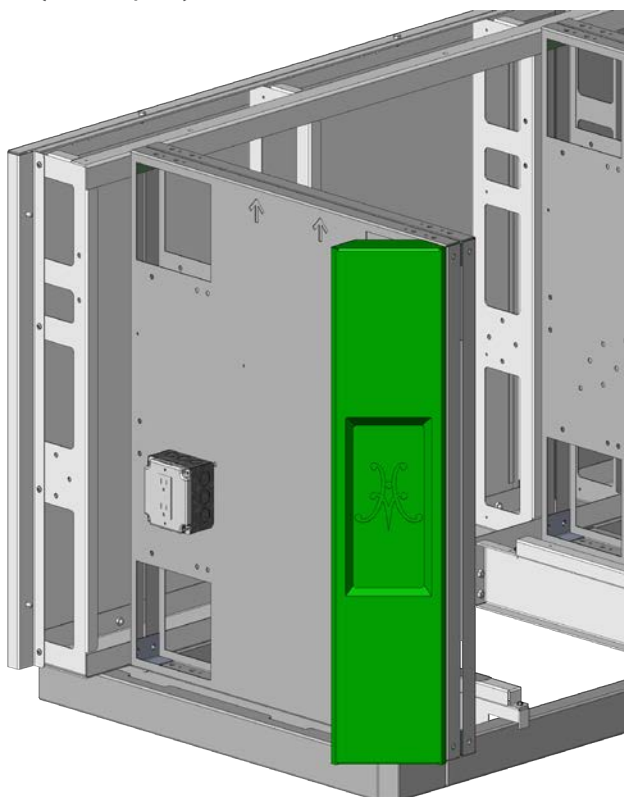



ELECTRICAL ITEMS

ELECTRICAL SUPPLY

The Hestan Outdoor Living Suite is completely pre-wired for ease of installation. The suite will require a 20 amp supply (breaker) from the house main electrical panel. The licensed electrician will have to run the appropriate wire size and conduit for this application. Rigid or flexible conduit suitable for burial with water-tight connections are highly recommended from the house main electrical panel, to the suite.

Important: The appliance(s) must be electrically grounded in accordance with local codes, or in the absence of local codes with the National Electrical Code, *ANSI/NFPA 70-1990*.

⚠ WARNING

Appliances (grill, side burner, refrigerators, etc.) are equipped with a flexible electrical supply cord featuring a three-prong grounding plug. It is imperative that this plug be connected to a properly grounded three-prong receptacle. If the receptacle is not the proper grounding type, contact an electrician. Do not remove the grounding prong from this plug.

The appliances are designed for 120 volt AC power and must be plugged into a Ground Fault Circuit Interrupter (GFCI) protected circuit. For gas-burning appliances, do not connect to the electrical supply until after gas connections have been made and leak checks have been performed.

KEEP ANY ELECTRICAL CORDS AND FUEL SUPPLY HOSES AWAY FROM ANY HEATED SURFACES.

- To protect against electric shock, do not immerse cord or plugs in water or other liquid.
- Unplug from the outlet when not in use and before cleaning. Allow to cool before putting on or taking off parts.
- Do not operate any outdoor cooking gas appliance with a damaged cord or plug, or after the appliance malfunctions or has been damaged in any manner. Contact the manufacturer for repair.
- Do not let the cord hang over the edge of a table or touch hot surfaces.
- Do not use an outdoor cooking gas appliance for purposes other than intended.
- Use only a Ground Fault Circuit Interrupter (GFCI) protected circuit with this outdoor cooking gas appliance.
- Never remove the grounding prong or use with a 2-prong ground adapter.
- Use only extension cords with a 3-prong grounding plug, rated for the power of the equipment, and approved for outdoor use with a W-A marking.

ELECTRICAL BOXES & CONDUIT

8. As mentioned in Step 1, a licensed electrician must run the electrical supply lines from the house main electrical panel (20 amp breaker), to the recommended area below the curb base. This supply is brought into the main electrical box as shown in the photo on the next page. The flex conduits coming out of this box are labeled "A" or "B". The electrician will make up the final connections as shown in the diagrams on the following pages.

This main electrical box contains a GFCI outlet, which protects all the "B" outlets. The "A" circuit runs to the weather-proof GFCI outlet located on the right side of the Suite, or to the outlets at the bar (for those models featuring a raised bar). Should the GFCI trip due to a fault at the Grill, Side Burner, or Refrigerator ("B" outlets), it must be reset, and the other "A" outlets will not be affected. Similarly, the "A" GFCI will not affect the "B" outlets if it trips due to a fault.



MAIN ELECTRICAL BOX SHOWING SUPPLY LINE ENTERING ON RIGHT SIDE OF BOX.

BACK VIEW

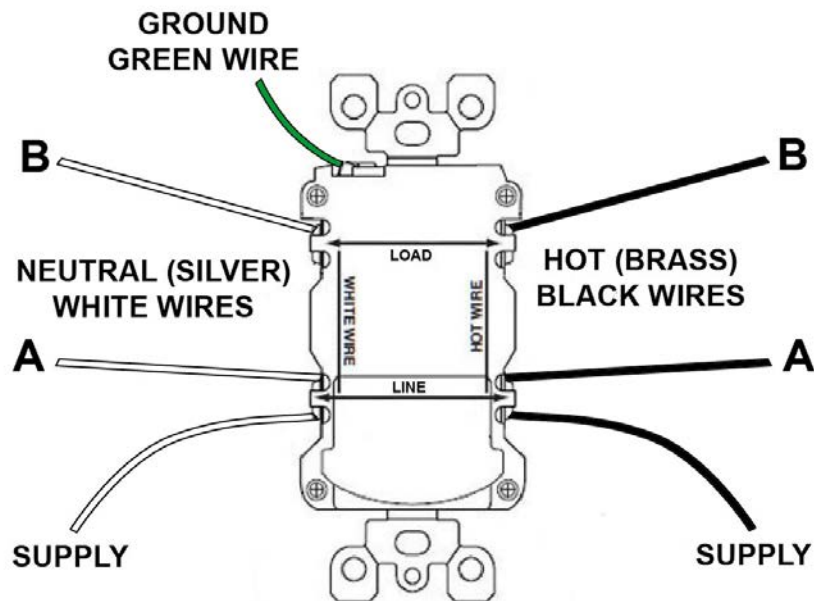



ELECTRICAL ITEMS *(continued)*

EN



MAIN ELECTRICAL BOX COMPLETE

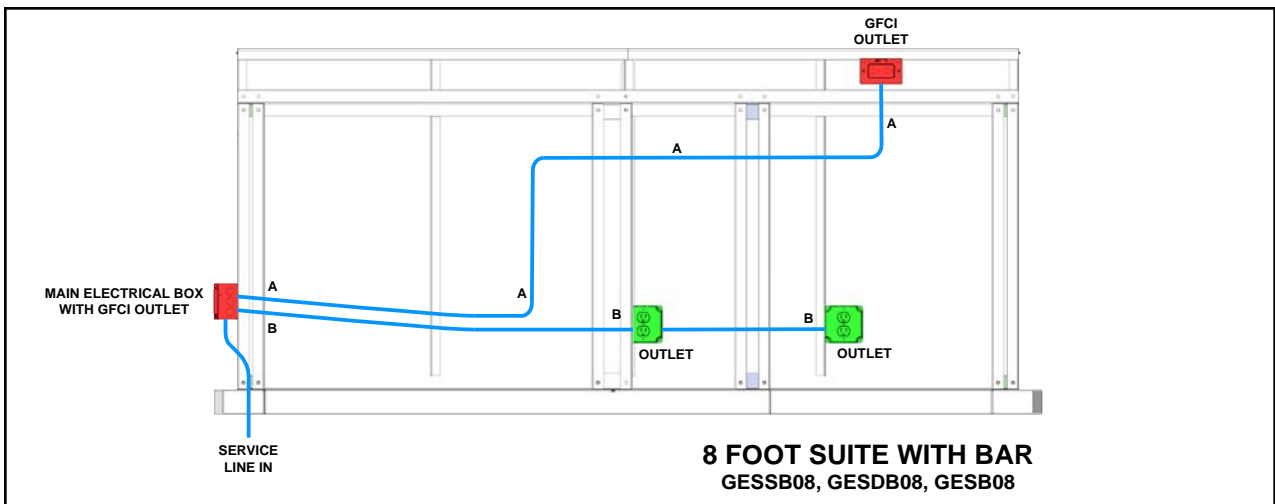
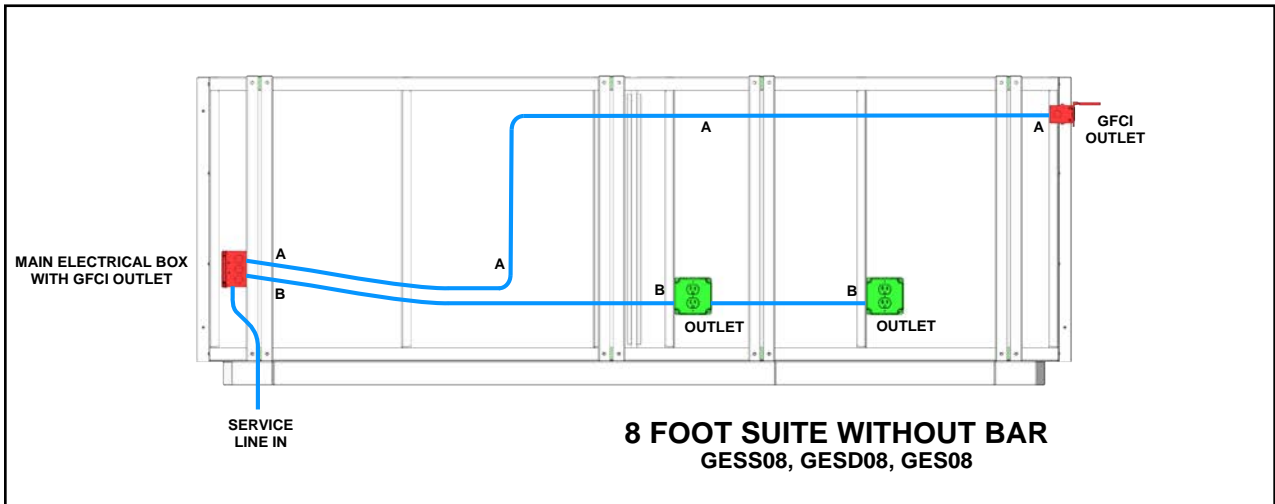

ELECTRICAL ITEMS (continued)



EN

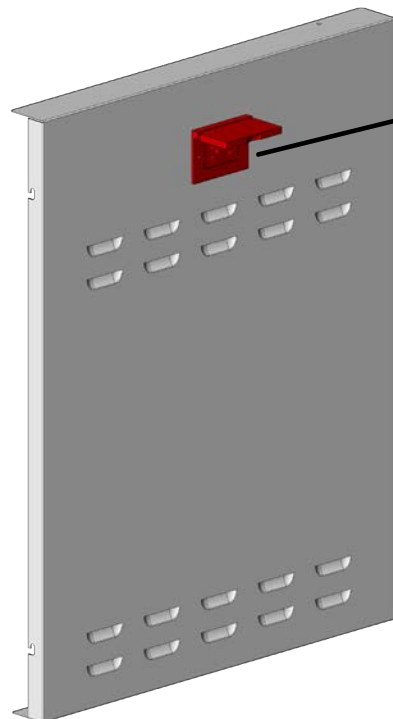
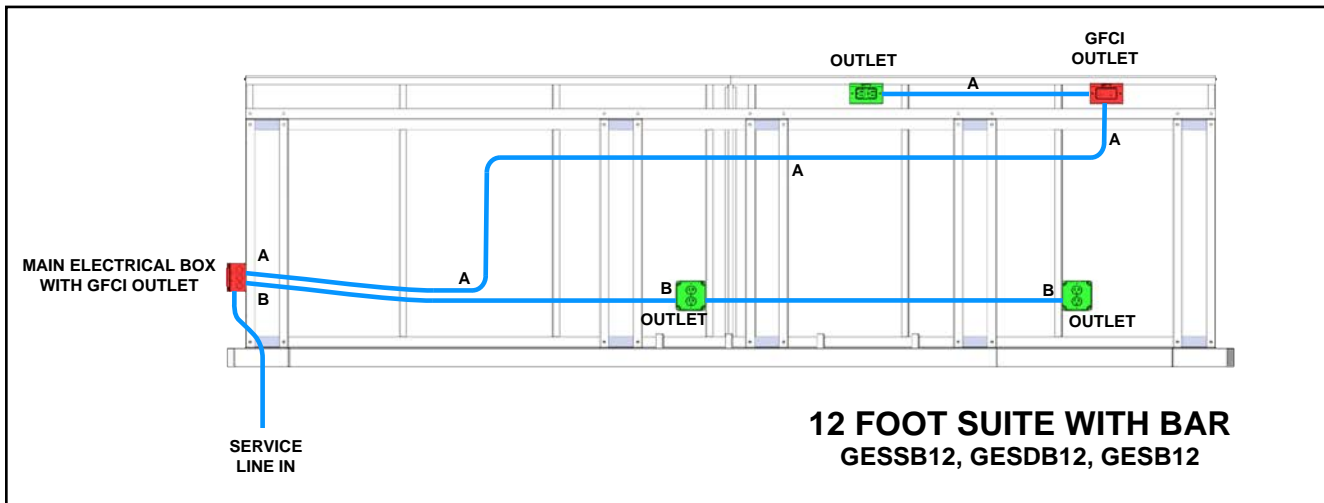
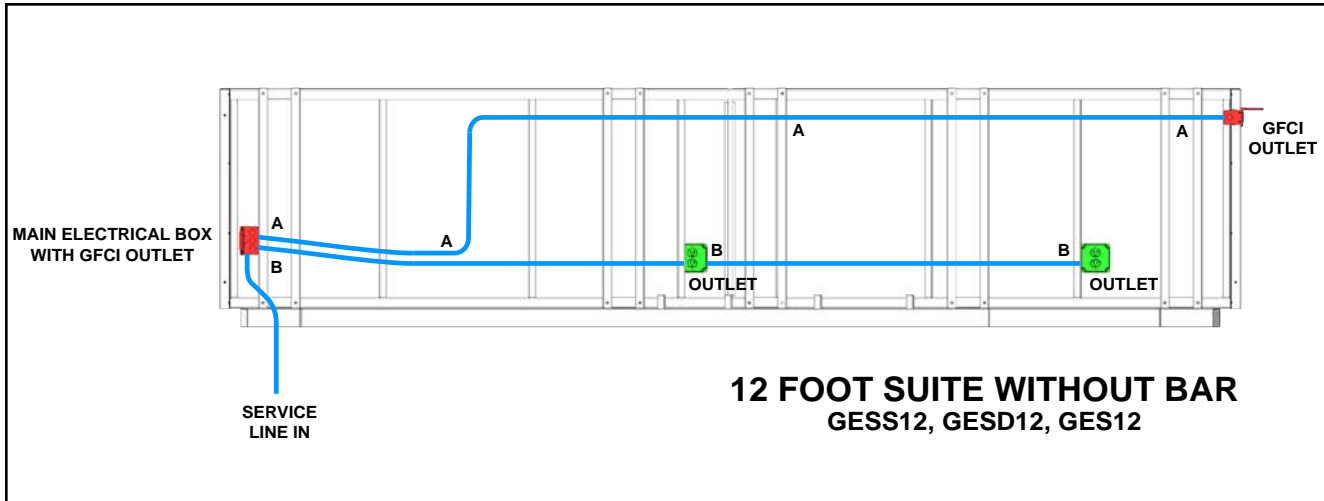

GFCI OUTLET WITH WEATHERPROOF COVER

RIGHT SIDE OF SUITE
(For Suite without Bar)



INSTALL OUTER PANELS

- The GFCI outlet on the right side of the suite is shipped loosely and must be passed through the space shown below and installed from behind the right panel (does not apply to Suite with a bar).



Line up and install 4 each #10 screws as shown here.

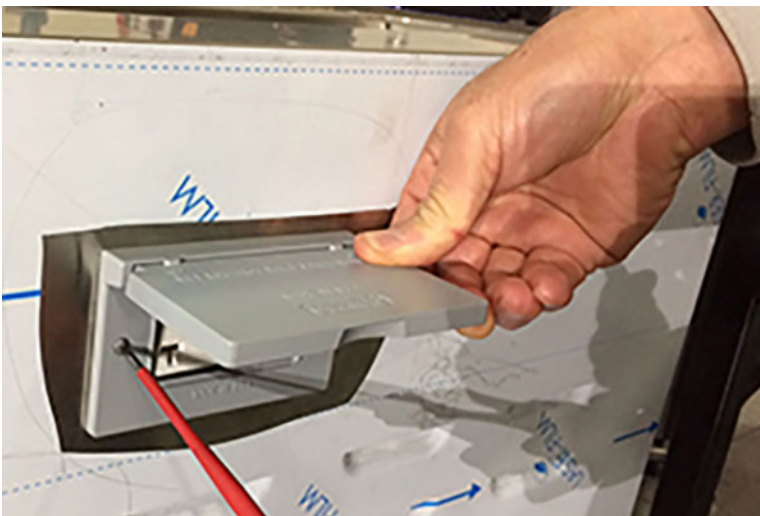
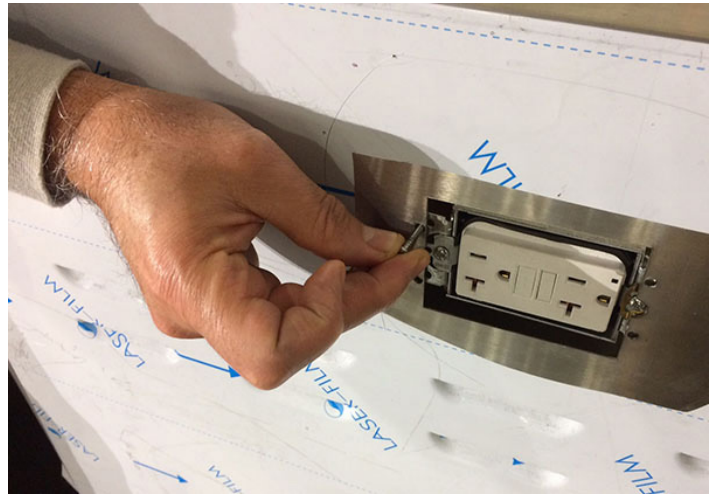

Install the foam gasket, and weather-proof cover with the screws provided.

INSTALL OUTER PANELS *(continued)*



EN

10. Install small front panel as shown using 2 each 1/4-20 x 1/2" long hex bolts and hex nuts. With wiring complete, secure right panel as shown with a #10 self-drilling screw.

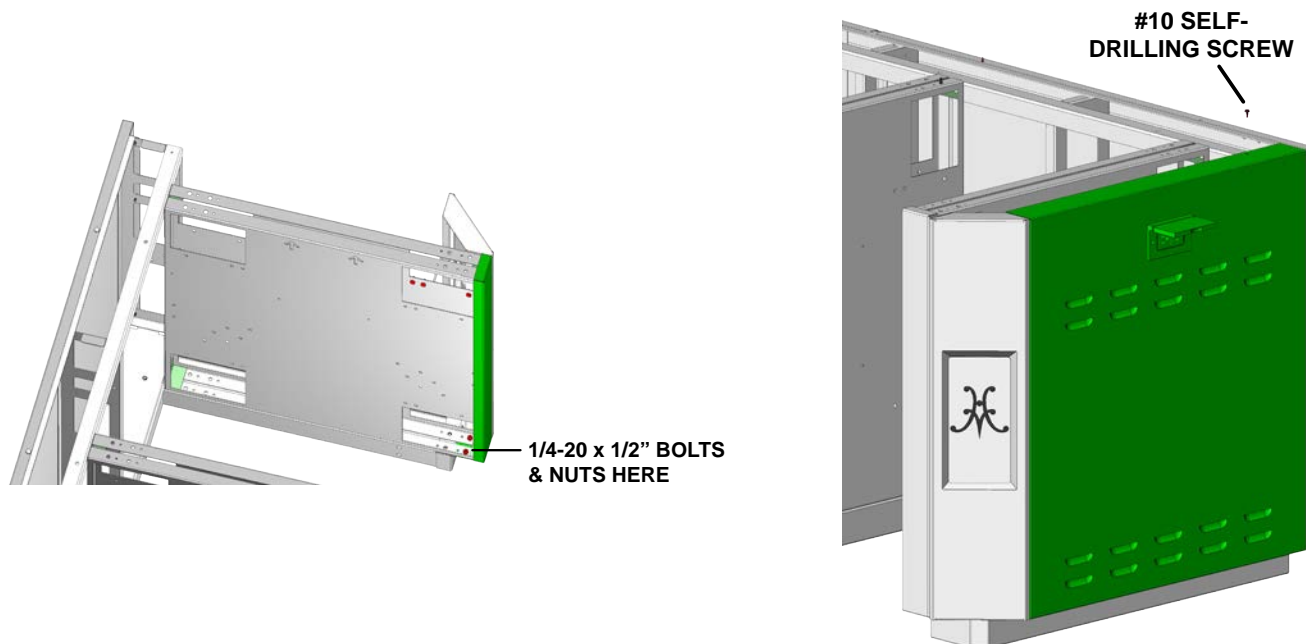

11. Install large front panel as shown using 1/4-20 x 1/2" long hex bolts and hex nuts located underneath the toe kick area shown below. Also install #8-32 flat-head screws across the top flange (8 foot Outdoor Living Suite shown).

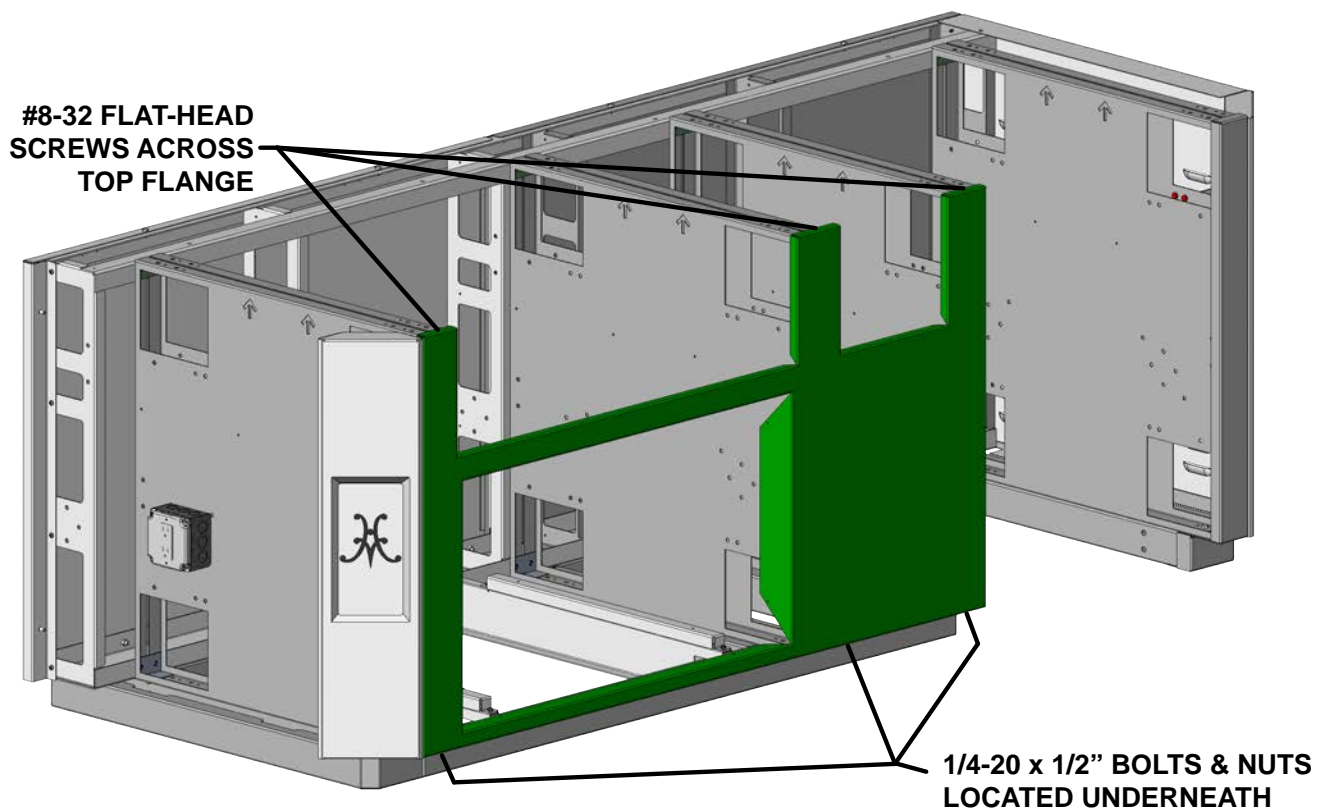



MOUNT GRILL ELECTRICAL BOX & LEFT PANEL

12. Mount the electrical box that came with your Hestan grill as shown and secure with #10 self-drilling screws provided. Use the provided Wire Harness Extension (p/n 009938) to connect the box to the grill wire harness. Arrange the wires in such a way to prevent damage during installation of the grill, and from heat. At this point, it is also recommended the plumber run the gas connections for the Grill and Side Burner (see pg. 19). As mentioned before, a gas shut-off valve must be located in a readily accessible location for shut-off when the appliances are not in use, or for servicing. See reference photos at the end of this manual.

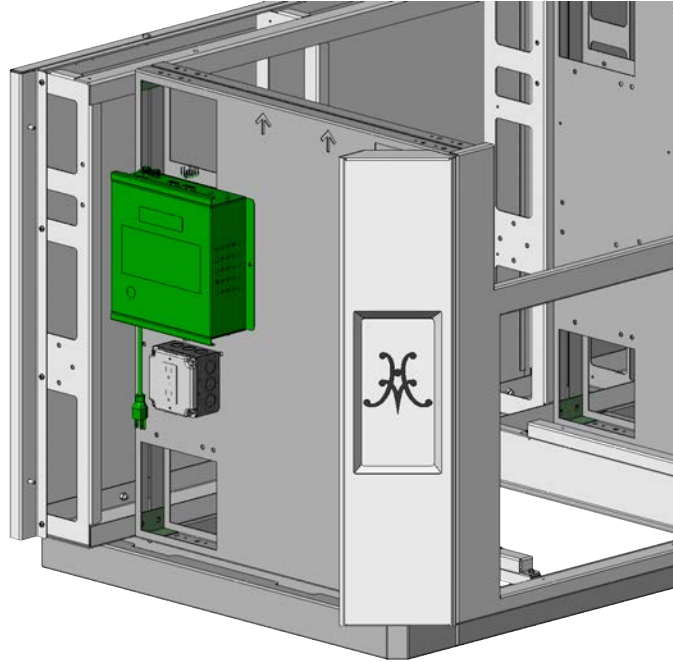

13. Mount the lift-off panel on the left side of the suite. There are pins on either side for locating. The louvers located on these side panels are needed for ventilation and must not be blocked. If this lift-off panel does not install/remove easily, you may need to adjust the corner assembly to accommodate (see Step 7).

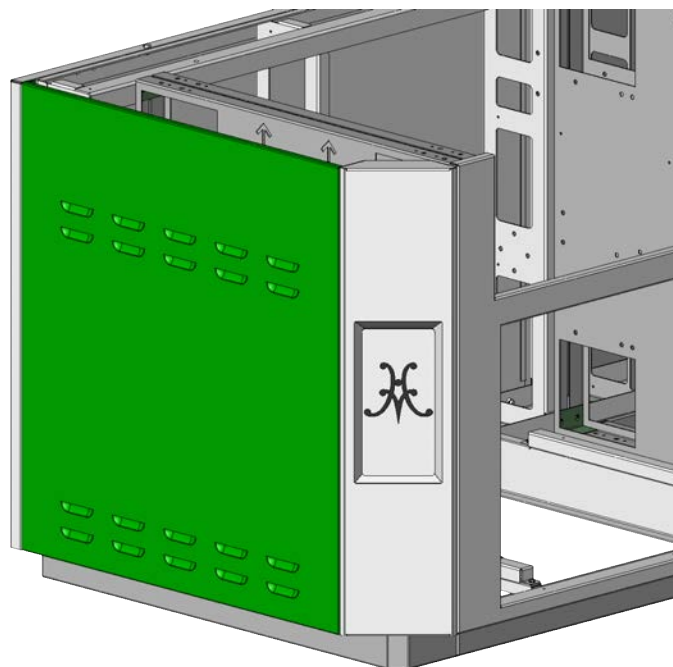

INSTALL SUPPORT STRUCTURE AND TOP



EN

The Hestan Outdoor Living Suite DOES NOT include the stone countertop and plywood sub-structure. Template drawings are provided at the end of this manual with RECOMMENDED final stone dimensions. You may choose to have slightly larger overhangs, different edge treatments, etc. The stone installer will typically come out a few days prior to installation to go over the dimensions and make a physical template of the top before cutting the slab you have chosen. The stone countertop must be supported beneath by a 3/4 inch thick plywood base (see below). Due to the outdoor application of this product, pressure-treated /marine plywood is recommended prior to laying down the stone. Be sure to arrange for this plywood to be provided with the stone countertop at the time of installation.

14. Before installing the top, you should now go back and tighten all bolts everywhere else in the suite.

Install the plywood sub-structure first. Get assistance from another person to help lift the plywood and position correctly. (8 foot Outdoor Living Suite shown)

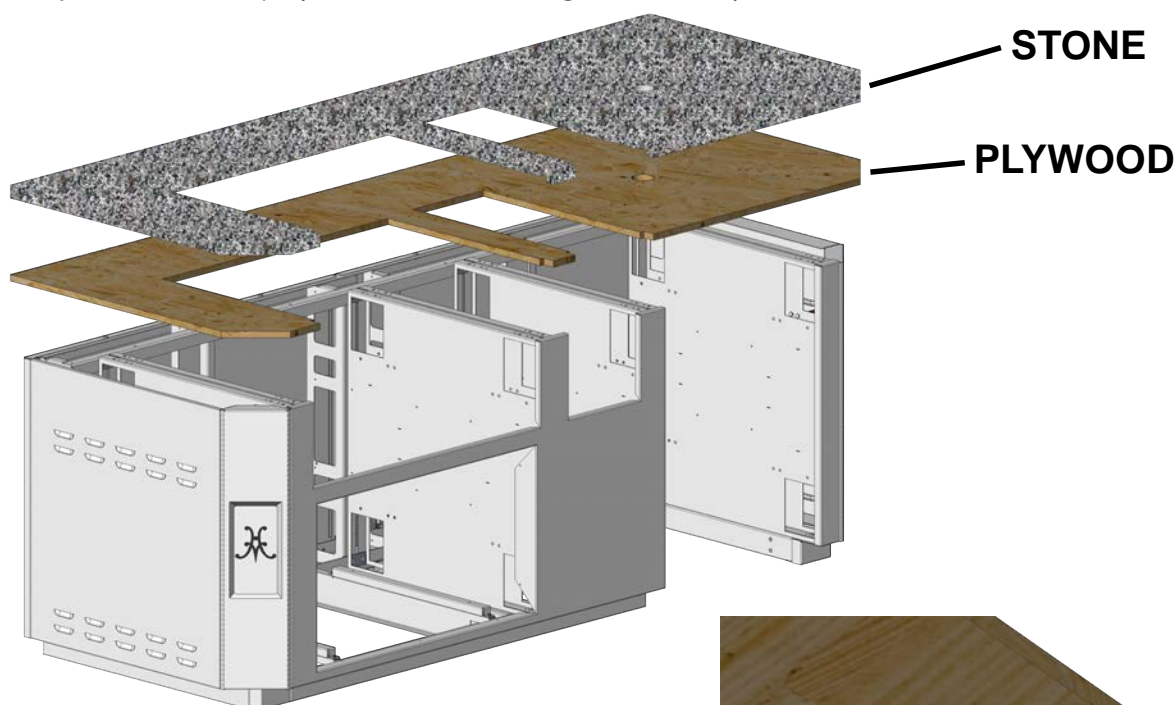

Use coated or stainless steel 1/2" long wood screws where needed to attach the plywood to the vertical walls in the small holes provided.



YOUR STONE INSTALLER WILL COMPLETE THE ASSEMBLY OF THE SUITE COUNTERTOP. YOU MAY THEN INSTALL THE APPLIANCES, CABINETS, AND OTHER PRODUCTS AS PER THE INSTRUCTION MANUALS SUPPLIED WITH THOSE PRODUCTS.

NOTE: IF YOU HAVE A SUITE FOR POWER BURNER OR KAMADO GRILL, SEE THE APPENDIX AT THE BACK OF THIS MANUAL FOR DETAILS BEFORE INSTALLING THE COUNTERTOP.



BAR TOP INSTALLATION (FOR MODELS WITH BAR)

HESTAN OUTDOOR LIVING SUITES WHICH FEATURE A BAR TOP (GESBx08 & GESBx12) FOLLOW THE SAME STEPS AS DESCRIBED EARLIER IN THIS MANUAL. STEPS UNIQUE TO THESE MODELS ARE DETAILED BELOW.

BACK AND SUPPORT WALL ASSEMBLY

1. Attach support wall #1 to curb assembly and back wall as shown using 6 each 1/4-20 x 1/2" hex bolts and hex nuts where needed.

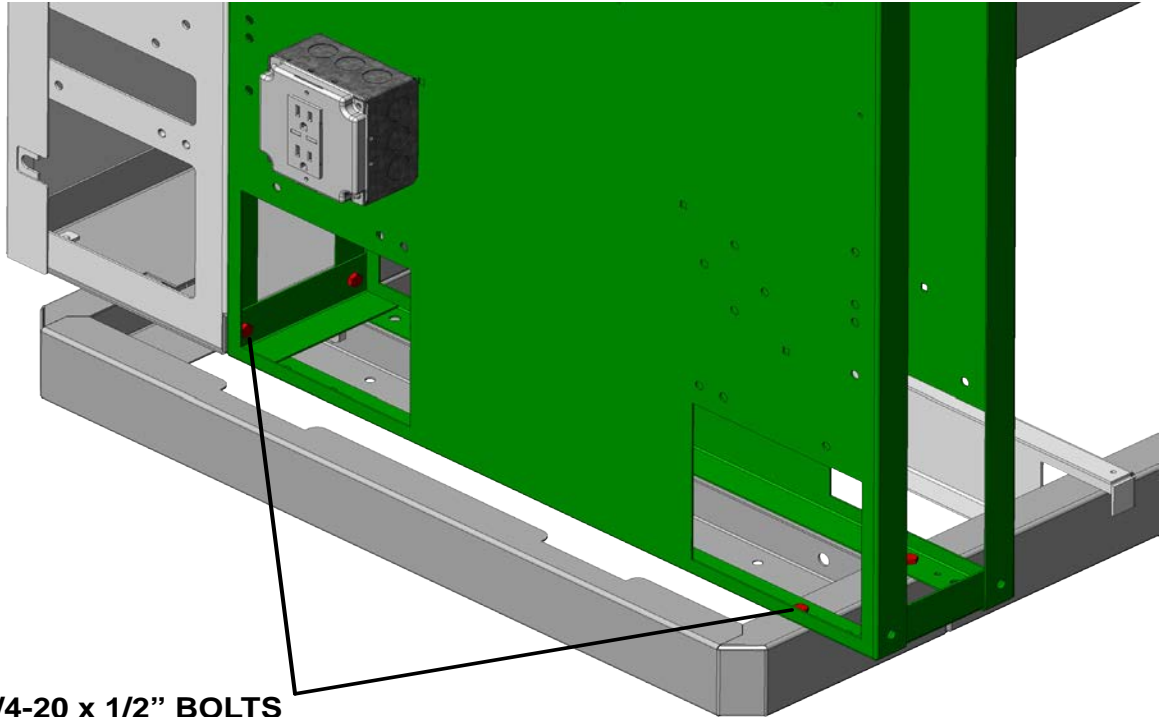

**1/4-20 x 1/2" BOLTS
& NUTS HERE**

2. Install remaining support walls as you did in step 1. Each wall is numbered and has a corresponding number on the curb and/or rear wall for ease of locating. (12 foot Outdoor Living Suite with Bar shown).

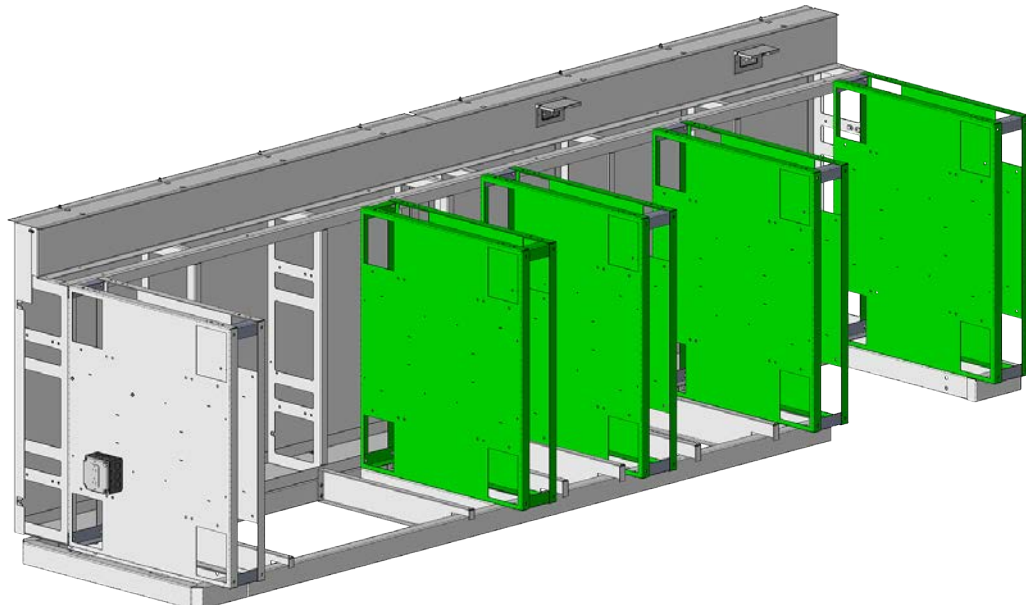

BAR TOP INSTALLATION *(continued)*



EN

3. The stone bar top will be supported by a metal support structure as shown below. Get assistance from another person to help lift the support and position correctly.

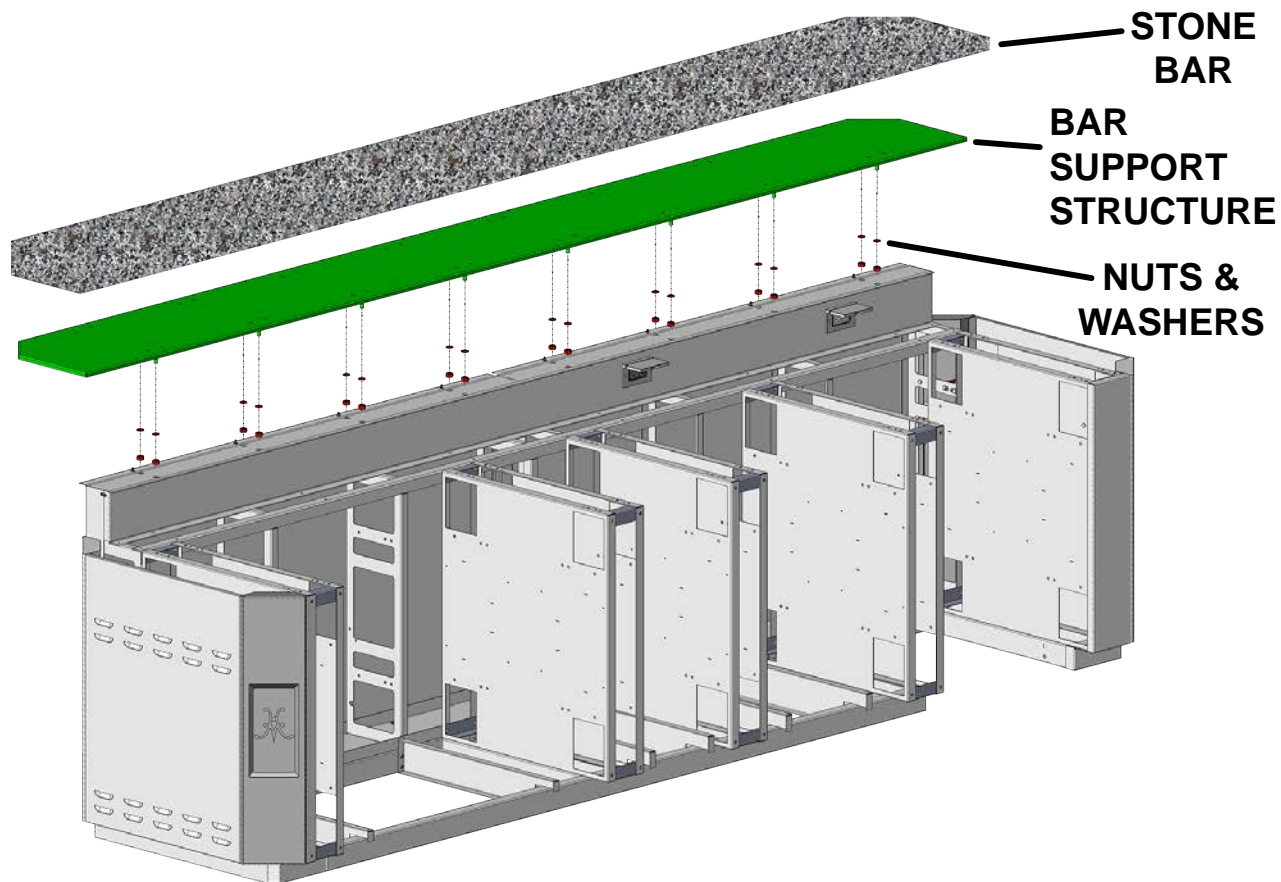

4. While an assistant is holding the bar top in place, reach underneath and secure the top with 1/2" nuts and lock-washers provided. Then secure the large back panels with 1/4-20 x 1/2" long bolts and flat washers. The stone itself is usually secured with an adhesive provided by the stone installer.

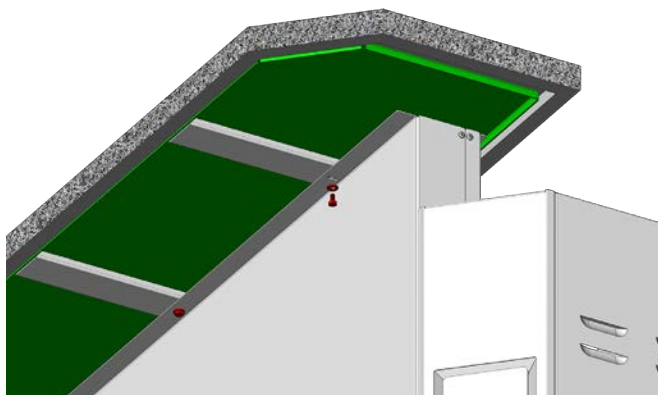
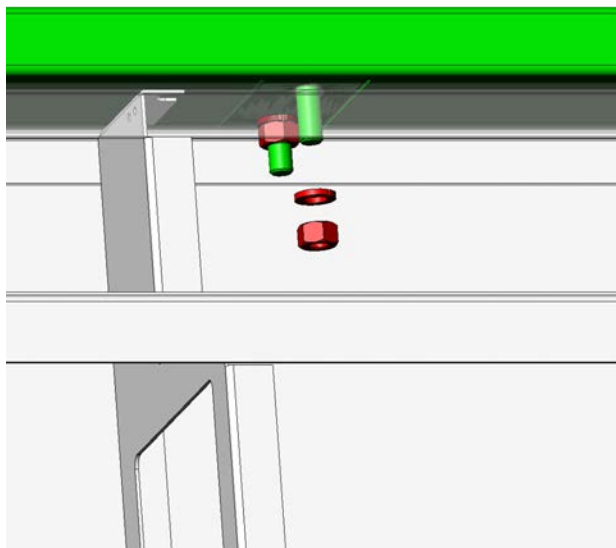



INSTALL COUNTERTOP

NOTE: IF YOU HAVE A SUITE FOR POWER BURNER OR KAMADO GRILL, SEE THE APPENDIX AT THE BACK OF THIS MANUAL FOR DETAILS BEFORE INSTALLING THE COUNTERTOP.

5. Install the countertop on top of the plywood sub-structure. Get assistance from another person to help lift the top and position correctly. The stone itself is usually secured with an adhesive provided by the stone installer. When complete, apply a bead of clear silicone sealant along the joint indicated.

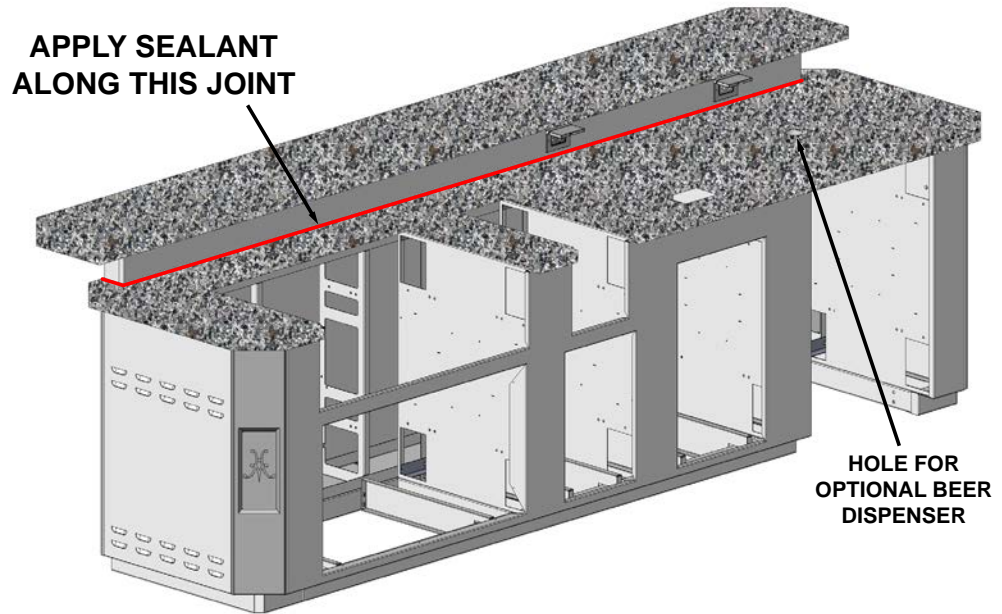

FOOTRAIL INSTALLATION (FOR MODELS WITH BAR)

NOTE: For installation of the footrail, it is assumed the curb base of the entire suite was installed on a flat and level concrete or masonry patio surface (see page 4). If the surface is not level, the bottom pads of each bracket may not rest fully on this surface. Also if you decide to tile around the suite after installation, the bottom pads of the footrail will still be on the same level as the underside of the curb base. Your tile installation will need to make allowances for this condition.

1. With a helper's assistance, install the footrail brackets on the rear wall as shown using #10-24 x 1/2" long flat-head mounting screws & locknuts on the opposite side of the wall. Do not fully tighten the screws yet. There is minimal vertical adjustment in these brackets to help with uneven floors.

Check to see if the setscrew in each bracket is backed out enough to allow the tube to pass through easily.

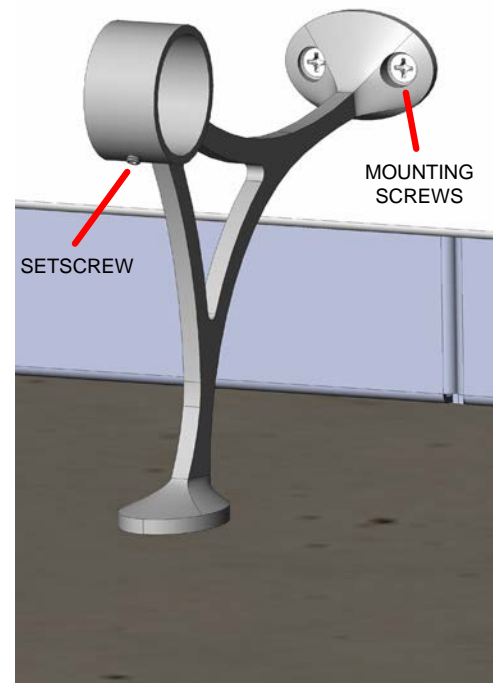

FOOTRAIL INSTALLATION *(continued)*



EN

2. Pass the textured tube through all footrail brackets. Check that an equal length of tubing is exposed beyond the left-most and right-most brackets. When you are OK with the position, lock the tube in place with all setscrews. Tighten all mounting bracket screws/nuts as well.
3. Attach endcaps to both ends of the tube and secure with setscrews on the bottom.

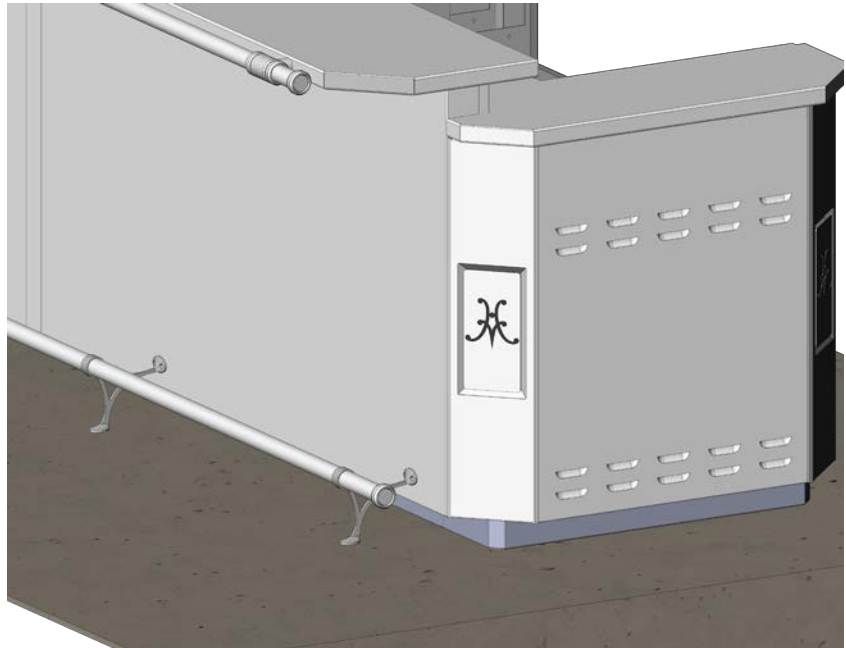
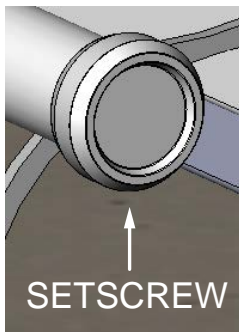

GAS CONNECTIONS AND FINAL ASSEMBLY



ASSEMBLY OF THE SUITE IS NOW COMPLETE. YOU MAY NOW INSTALL THE APPLIANCES, CABINETS, AND OTHER PRODUCTS AS PER THE INSTRUCTION MANUALS SUPPLIED WITH THOSE PRODUCTS.

GAS SUPPLY

Gas connections should be made by a qualified plumber, or your professional outdoor appliance installer.

All fixed (non-mobile) appliances must be fitted with an accessible upstream gas shutoff valve as a means of isolating the appliance for emergency shut off and for servicing. See reference photo at the end of this manual.

Make certain new piping and connections have been made in a clean manner and have been purged so that piping compound, chips, etc. will not clog regulators, valves, orifices, or burners. Use pipe joint compound / thread sealant approved for natural and LP gases.

NEVER CONNECT THE GRILL OR SIDE BURNER TO AN UNREGULATED GAS SUPPLY. Before proceeding, ensure the appliance is fitted for Natural or Liquid Propane gas. Connecting to an improper gas type will result in poor performance and increased risk of damage or injury. Gas type and gas consumption (BTU per hour) for each burner type is shown on the rating label affixed to each appliance.

Installation of this cooking appliance must be made in accordance with local codes. In the absence of local codes, this unit should be installed in accordance with the National Fuel Gas Code No. Z223.1/ *NFPA 54*, Natural Gas and Propane Installation code *CSA B149-1*, or Propane Storage and Handling Code B149.2.

NOTE: See rating label for manifold pressure for the type of gas of your appliance.

NOTE: If your Suite is to be connected to a Whole-House LP Piped System, please read the GAS CONNECTIONS section of your Hestan Grill manual for information on this unique installation, and to contact Hestan Customer Service to order an LP Piped System Kit.



GAS CONNECTIONS AND FINAL ASSEMBLY *(continued)*

1. The Outdoor Living Suite is shipped with an interplumb kit to simplify connecting side burner and grill together as shown below. HOWEVER, EACH APPLIANCE MUST BE CONNECTED TO ITS OWN REGULATOR. DO NOT USE ONE REGULATOR FOR BOTH APPLIANCES.

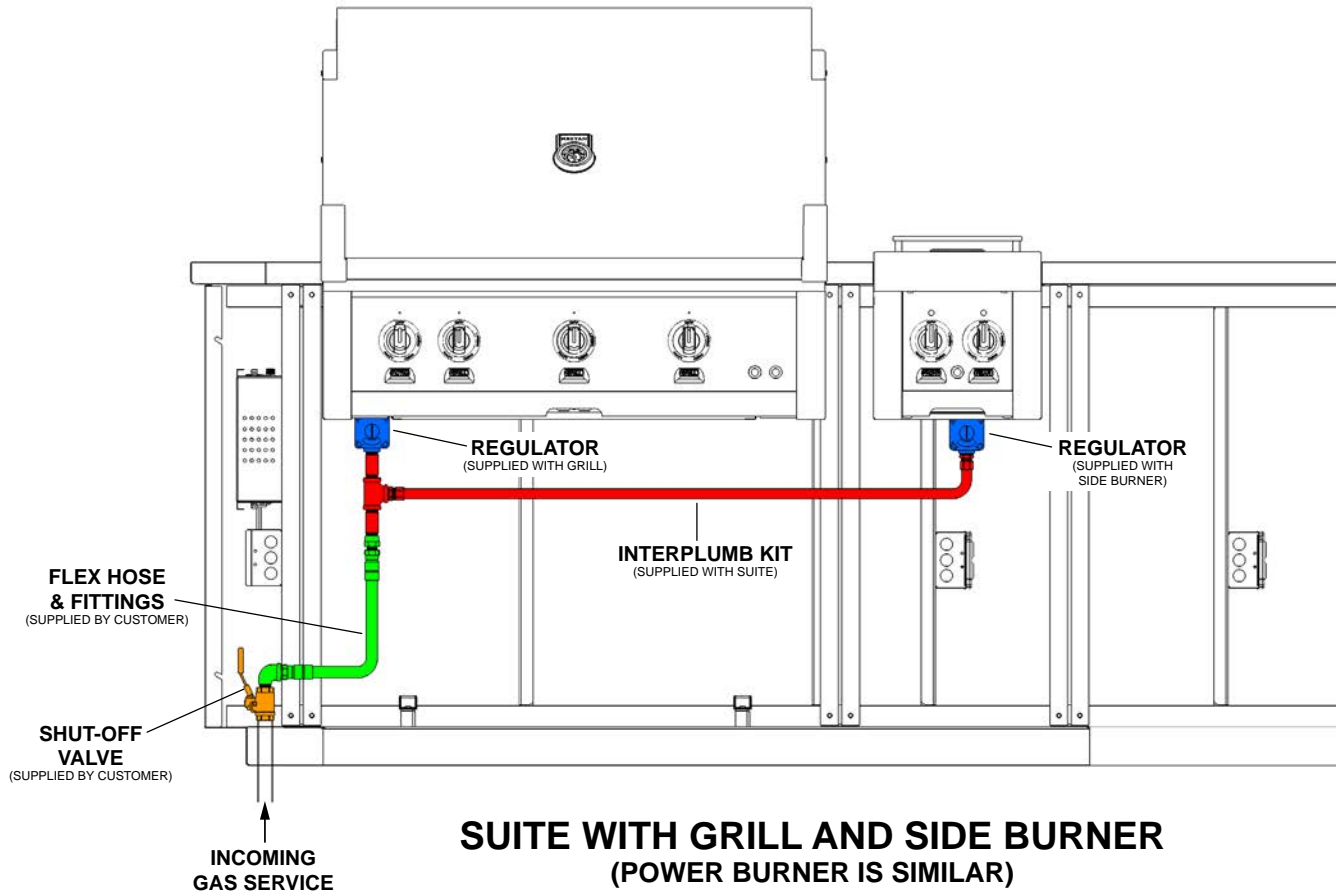

2. The remaining gas connections shown above must be completed by the qualified plumber or professional outdoor appliance installer. See reference photo on the next page for typical flex hose and shut-off valve location. Flex hose, shut-off valve, and misc. fittings must be provided by the homeowner and installed by the qualified plumber or professional outdoor appliance installer. The gas regulator is supplied with the grill & side burner (or power burner).

The above image is a suggestion only. Depending on which cabinetry was selected to go beneath the grill, it may be necessary for the plumber to route the regulator, fittings, and hoses in a different configuration to allow for the installation of the cabinet.

At all times, the shut-off valve must be located near the left side of the suite, near the floor, so it is easily accessible for service or emergency shut-off (see reference photos on next page).

A FULL LEAK TEST MUST BE PERFORMED ON ALL GAS CONNECTIONS & HOSES BEFORE USING THE APPLIANCES. Refer to the appliance manuals for instructions on this very important step.

REFERENCE PHOTOS



EN



INCOMING GAS SUPPLY
w/ SHUTOFF VALVE,
ELBOW & FLEX HOSE



GRILL HARNESS
EXTENSION
P/N 009938

INCOMING
ELECTRICAL
SUPPLY

ELECTRICAL AND GAS CONNECTIONS SUPPLIED BY CUSTOMER



RECOMMENDED STONE DIMENSIONS

EN

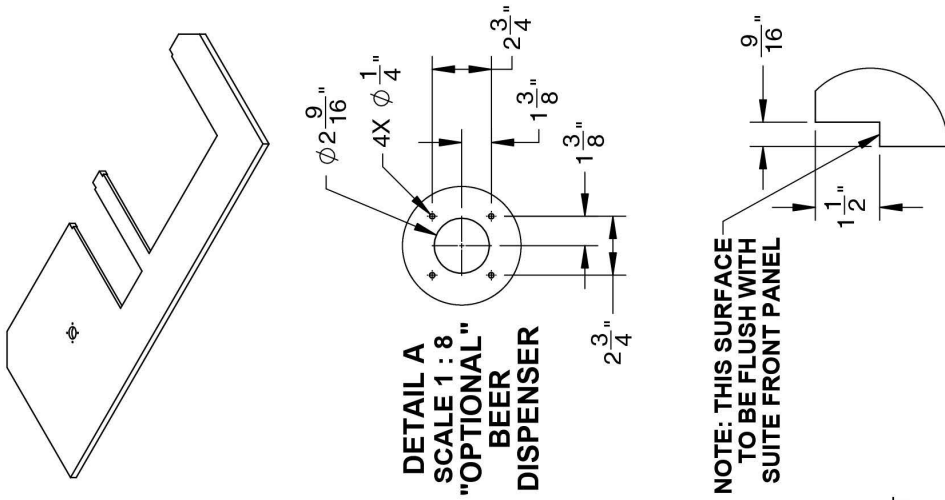

DETAIL B
SCALE 1 : 4
4-PLCS

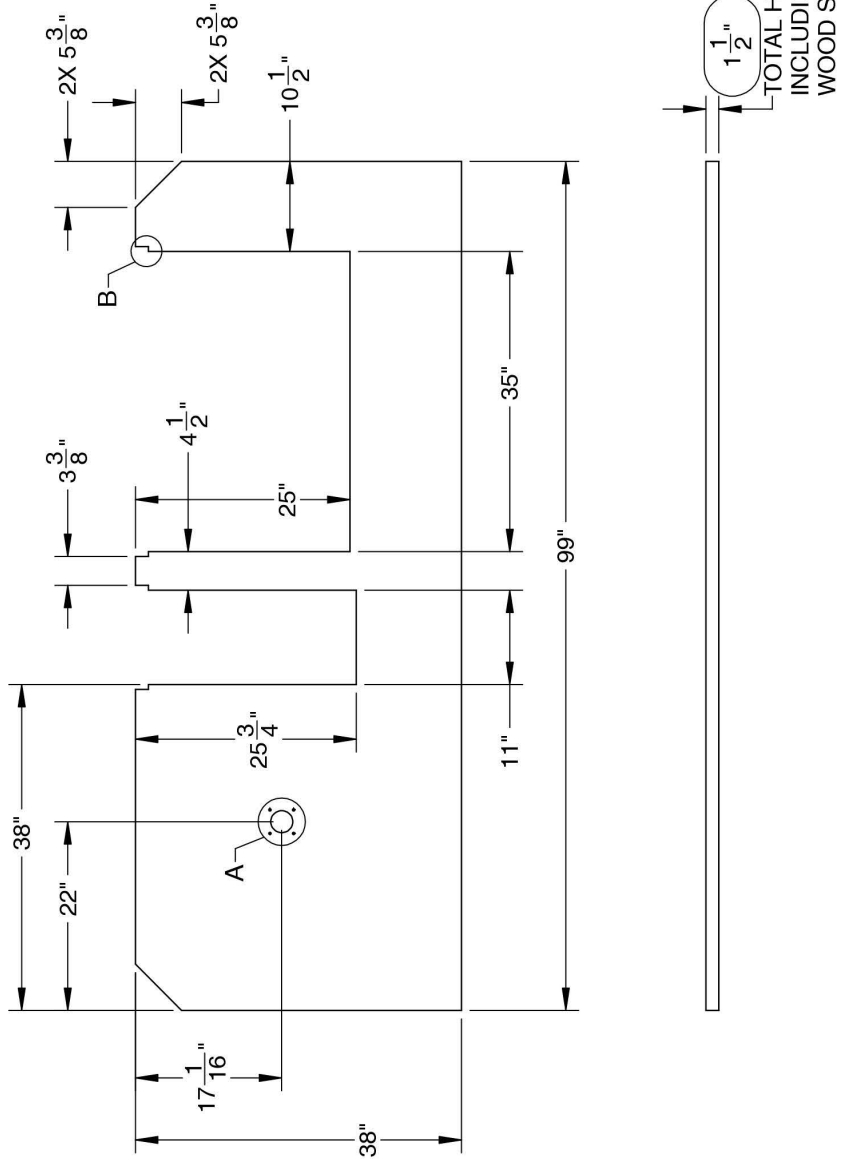

RECOMMENDED STONE DIMENSIONS *(continued)*

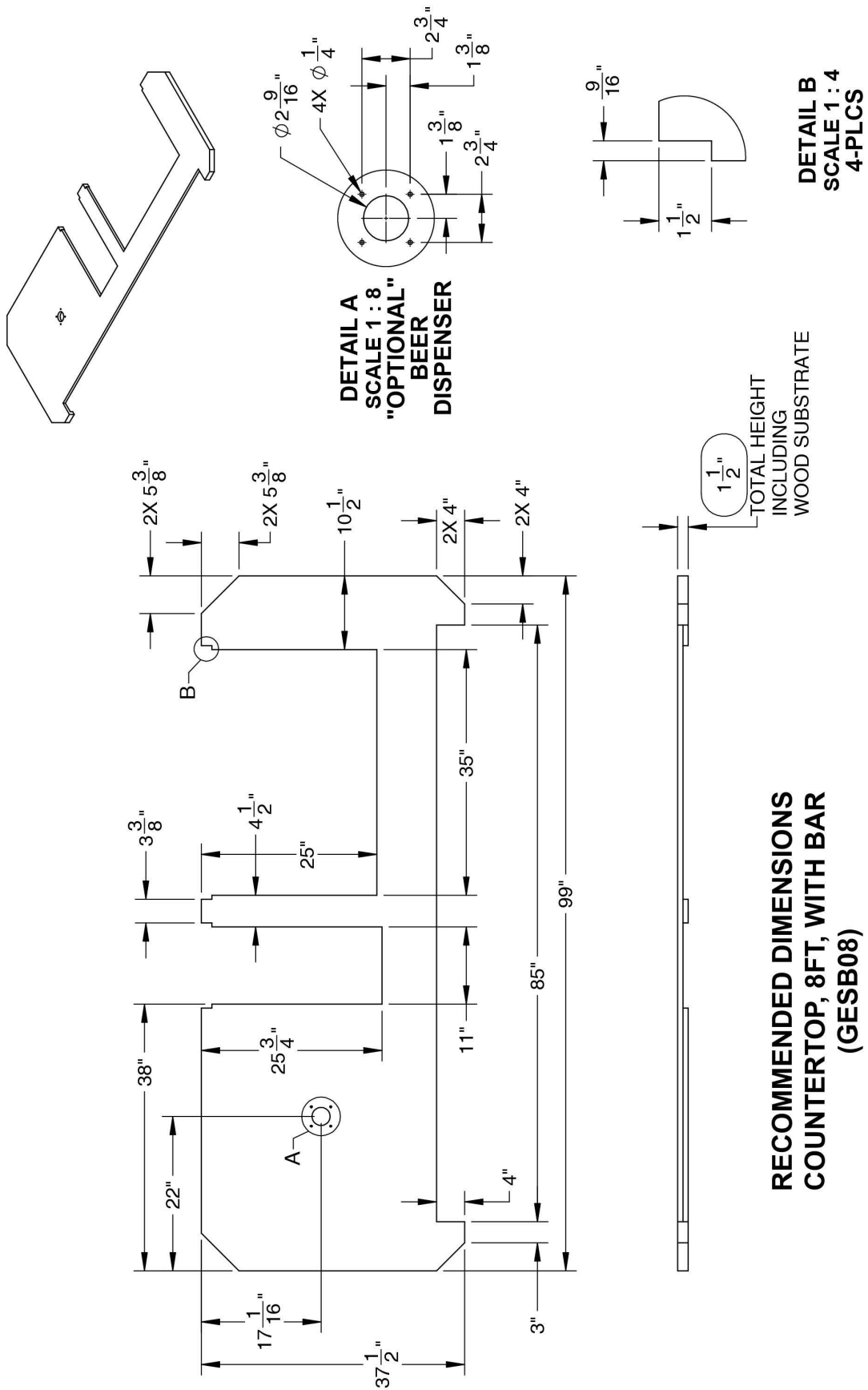

EN



RECOMMENDED STONE DIMENSIONS *(continued)*

EN

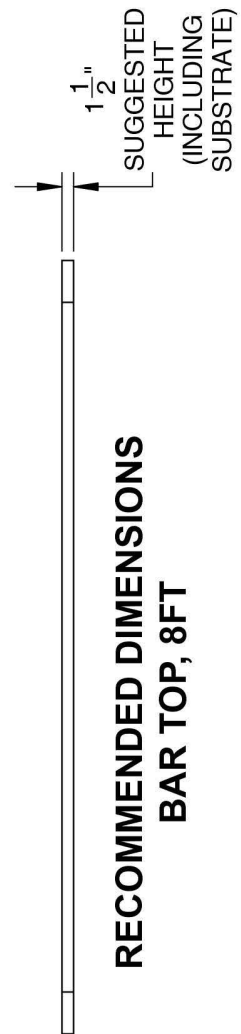
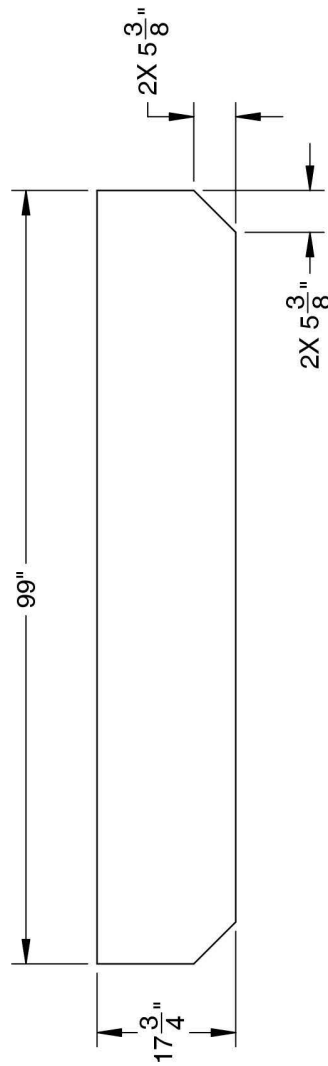
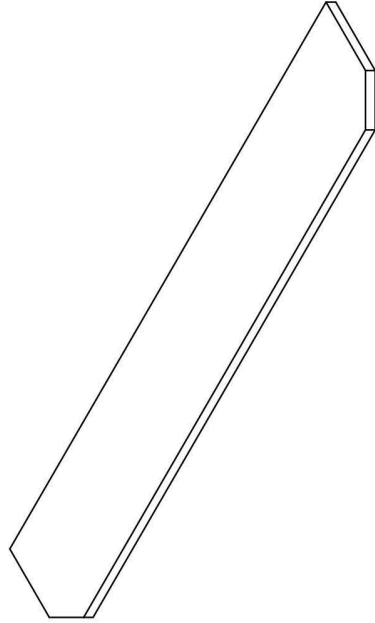

RECOMMENDED STONE DIMENSIONS *(continued)*



EN

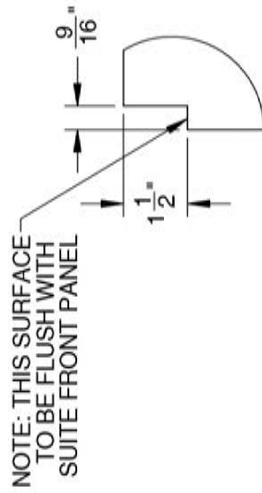
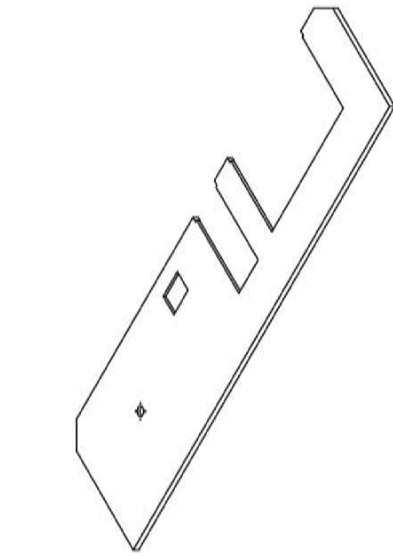

DETAIL B
SCALE 1 : 4
4-PLCS

NOTE: THIS SURFACE
TO BE FLUSH WITH
SUITE FRONT PANEL

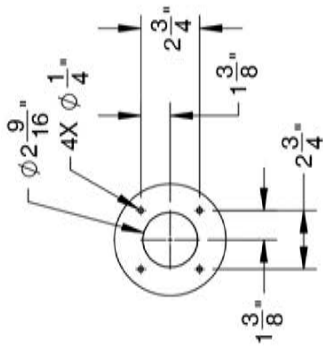

DETAIL A
SCALE 1 : 8
"OPTIONAL"
BEER
DISPENSER

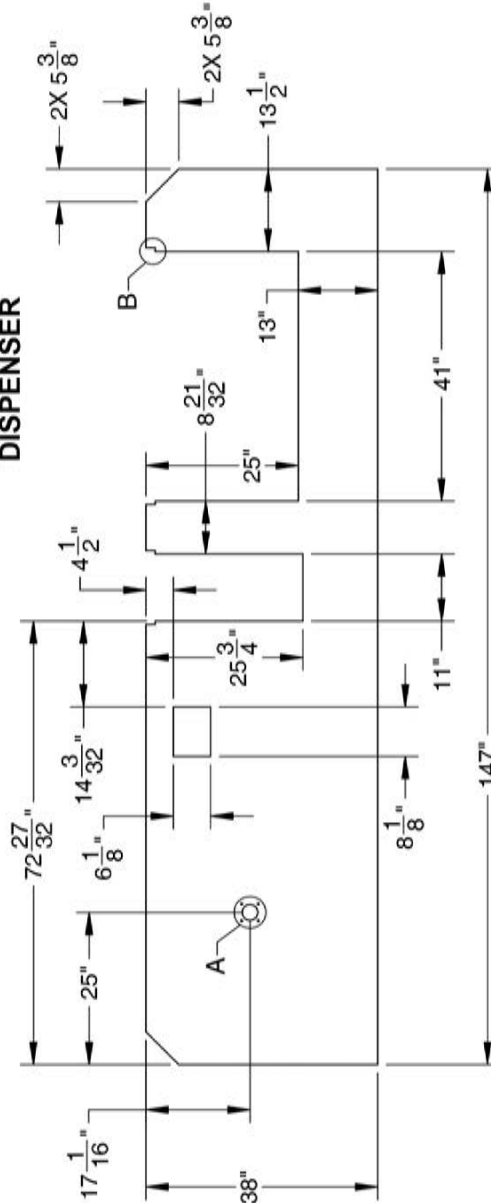

RECOMMENDED DIMENSIONS
COUNTERTOP, 12FT, NO BAR
(GES12)



RECOMMENDED STONE DIMENSIONS *(continued)*

EN

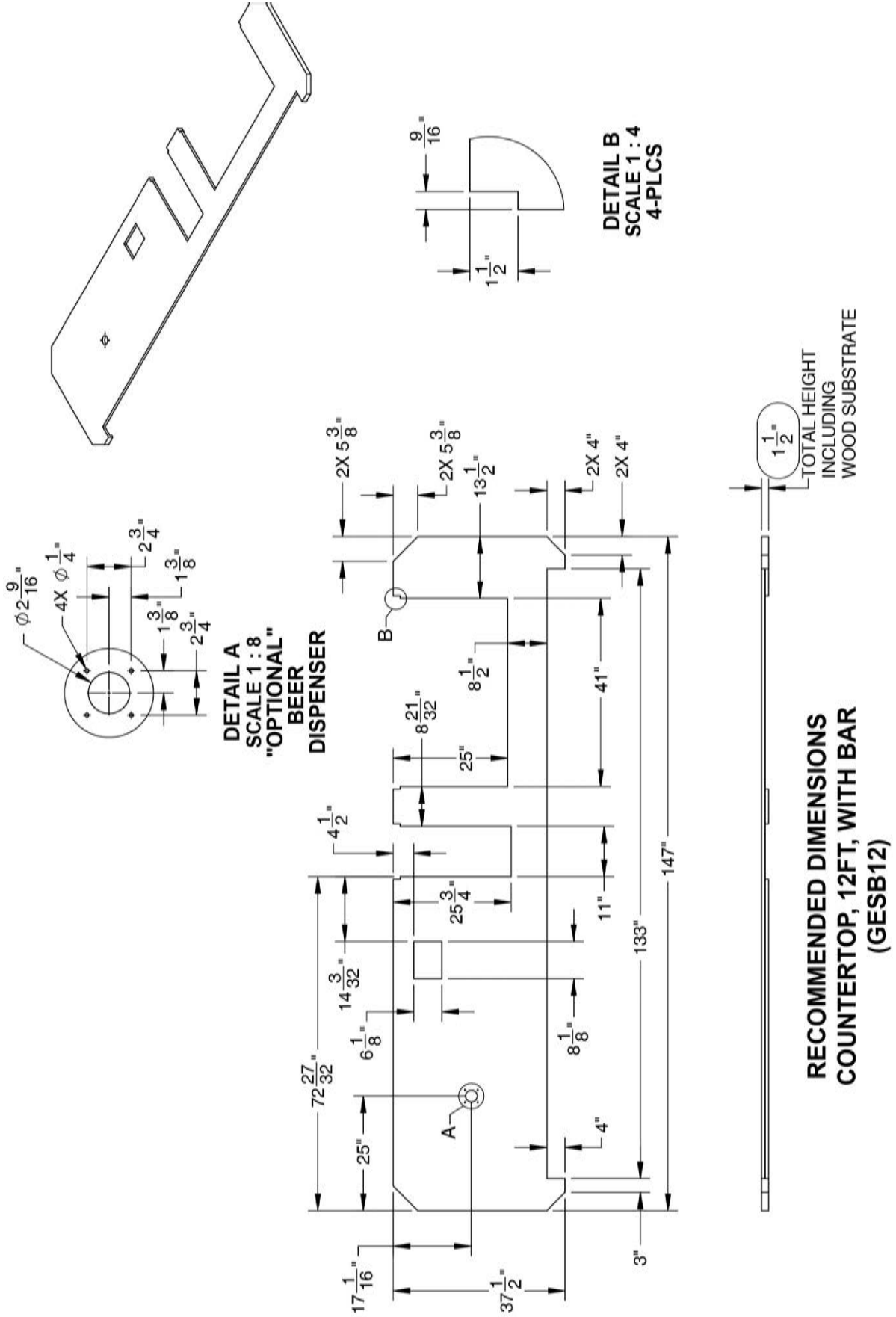

RECOMMENDED STONE DIMENSIONS *(continued)*



EN

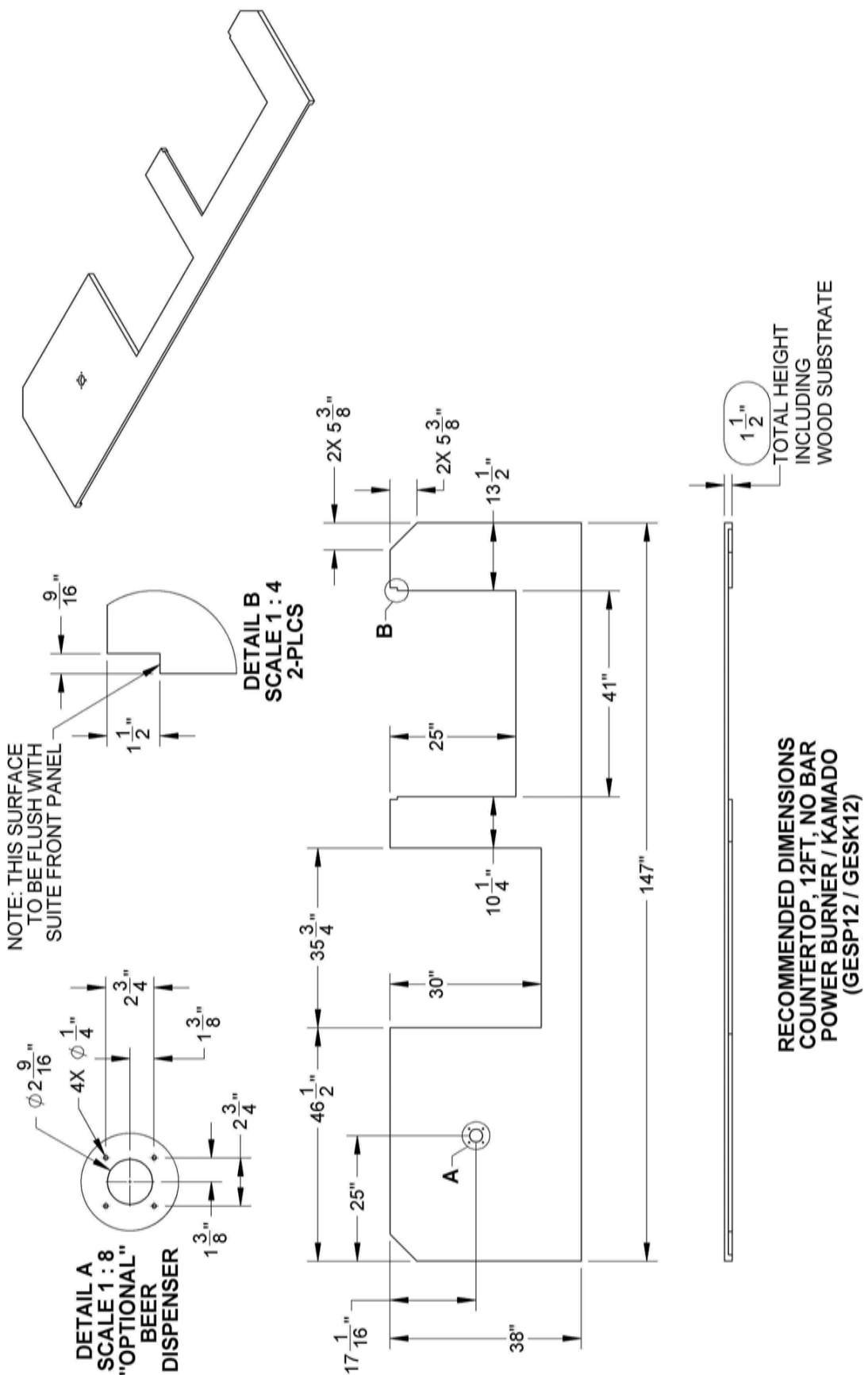



RECOMMENDED STONE DIMENSIONS *(continued)*

EN

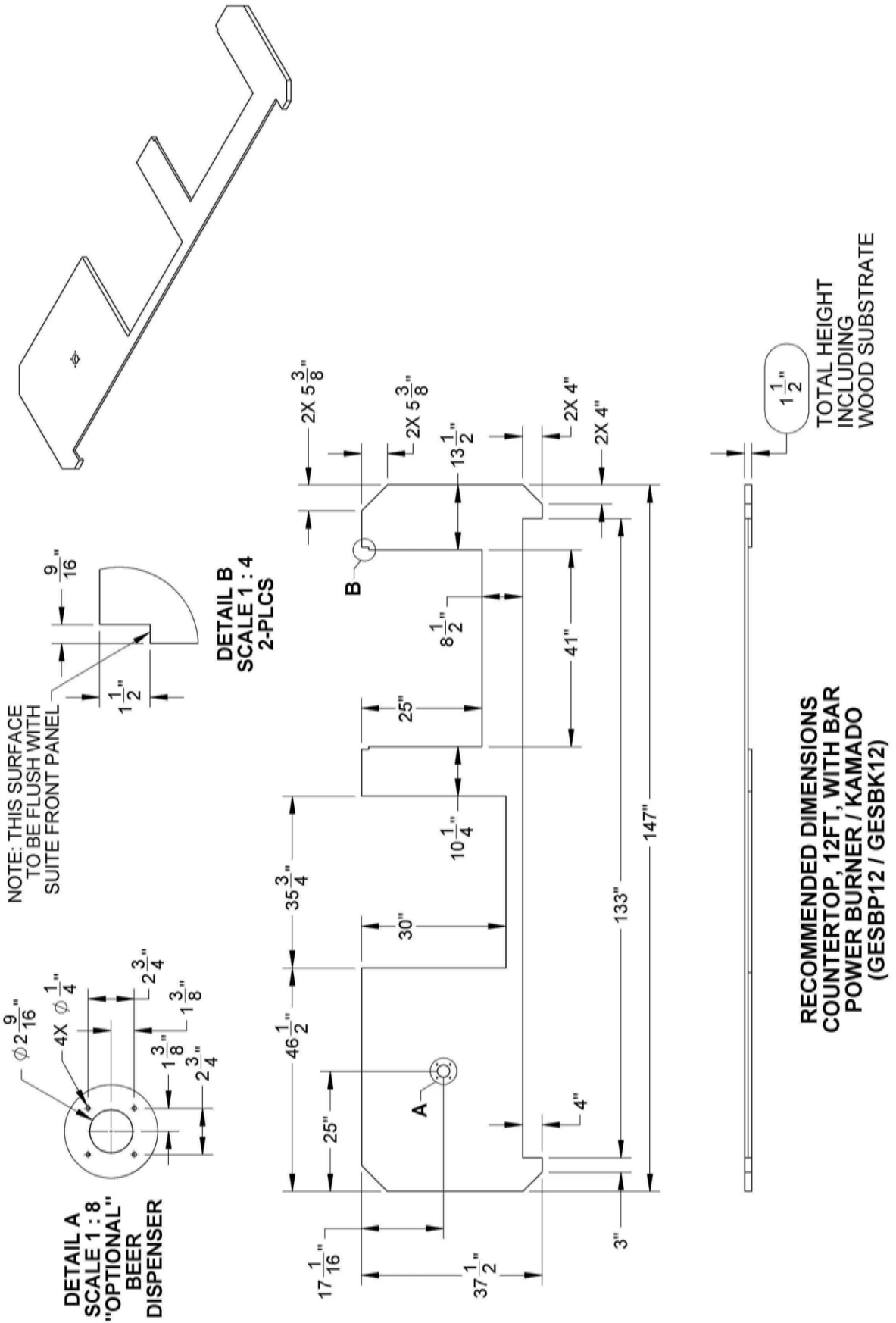

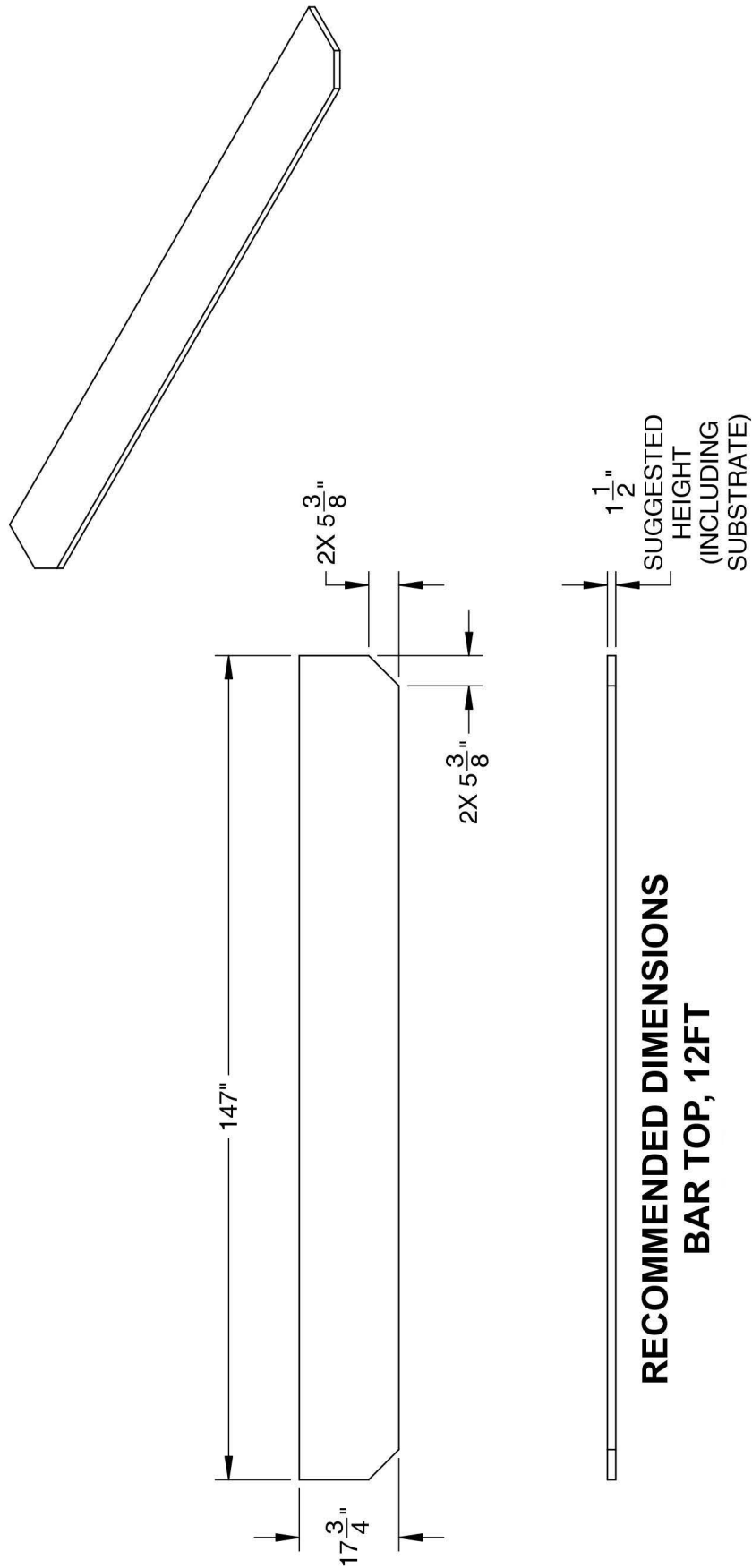



APPENDIX - POWER BURNER SUITES

1. The Outdoor Living Suite with Power Burner features an alcove for the appliance which must be set in place as shown below, then the plywood sub-structure must be secured, then the large stone countertop. Get assistance from another person to help lift the top and position correctly.

EN

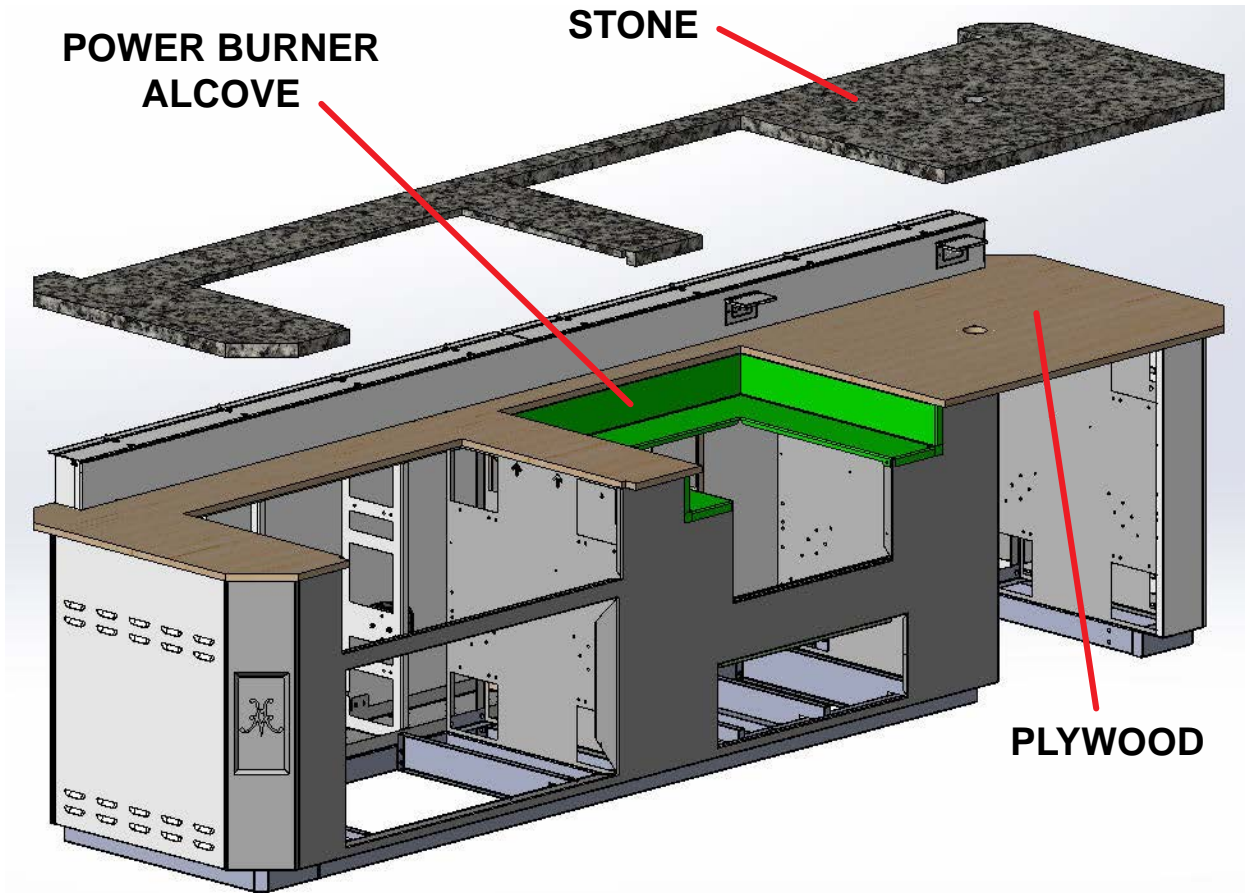

2. There are two (2) #8-32 x 3/8" flathead countersunk screws which attach the alcove to the front panel.

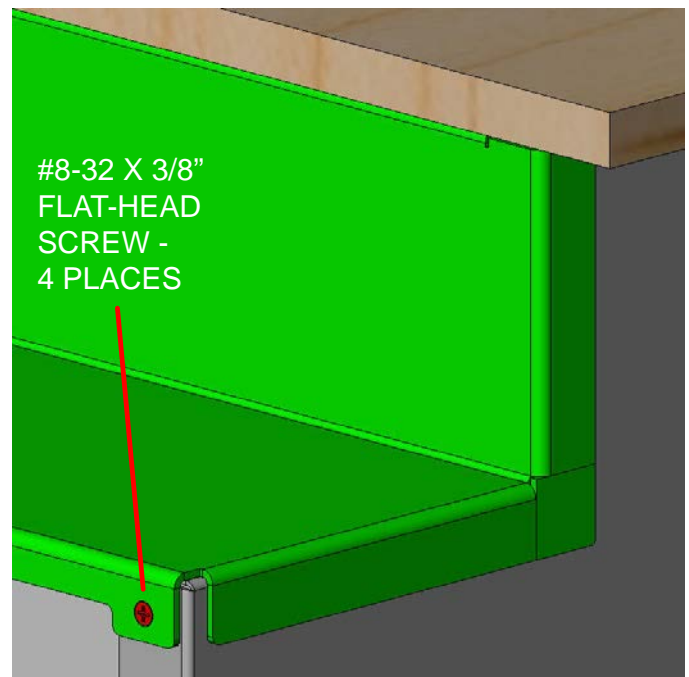

APPENDIX - POWER BURNER SUITES *(continued)*



3. Use coated or stainless steel 1/2" long wood screws where needed to secure the vertical walls and alcove to the underside of the plywood, using the small holes provided.

Tighten any remaining bolts underneath and return to step 5 on pg. 18 to complete the procedure.

EN

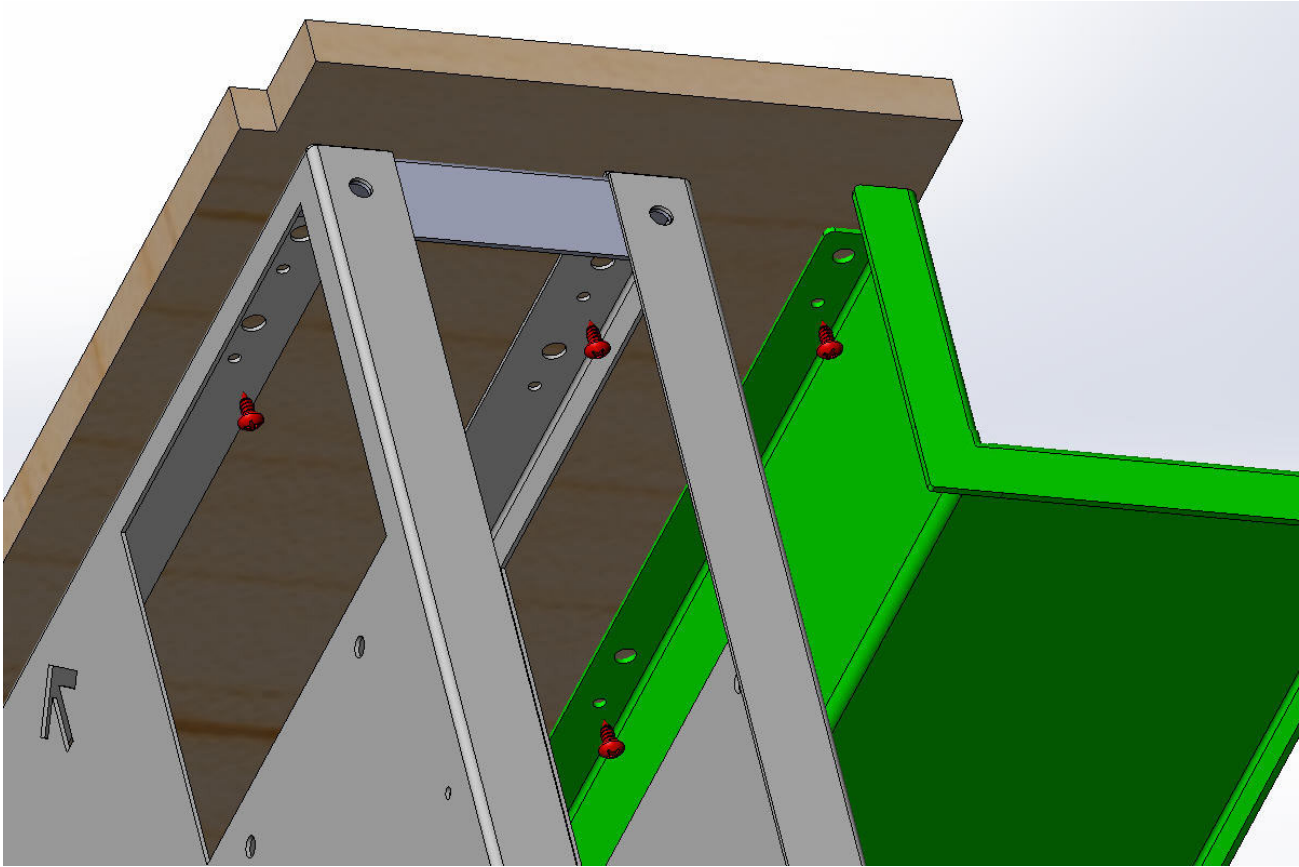



APPENDIX - KAMADO GRILL SUITES

1. The Outdoor Living Suite for Kamado Grill has a large crossmember which must be installed before the top and alcove can be installed. Note the "L" stamped into the crossmember for correct orientation.

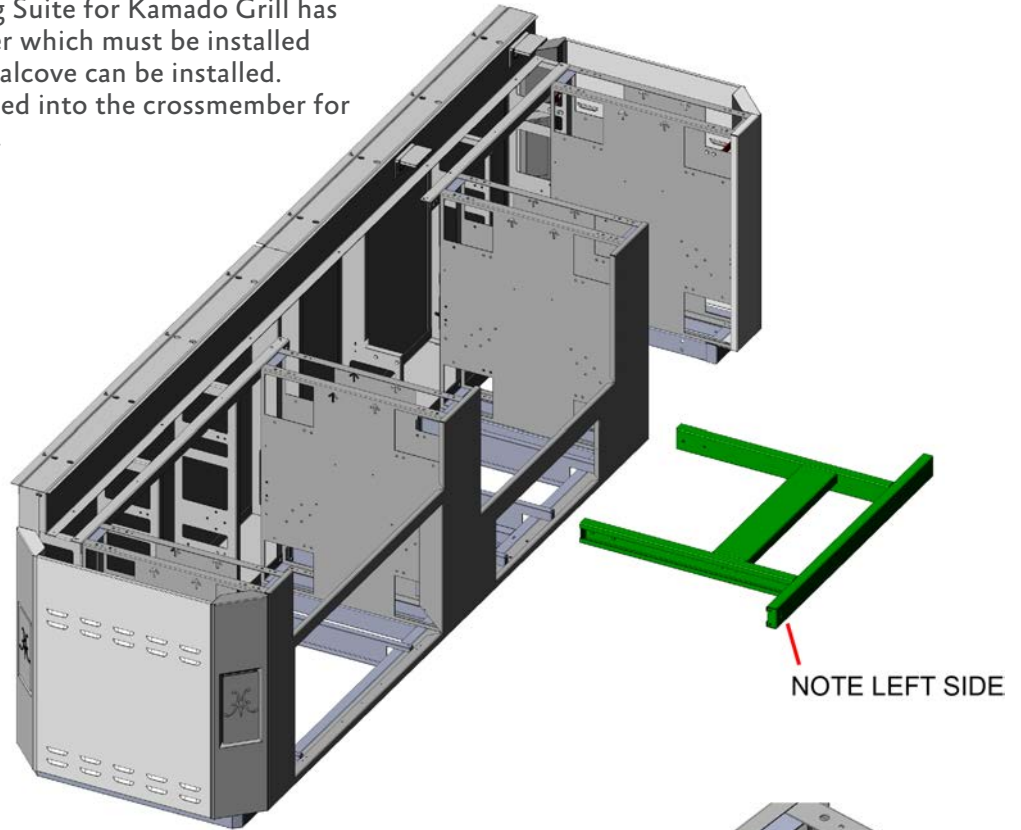

2. Attach crossmember by tucking under the flange of the front panel, and using 4 each 1/4-20 x 1/2" hex bolts where needed. Access is from the other side of the adjacent walls.

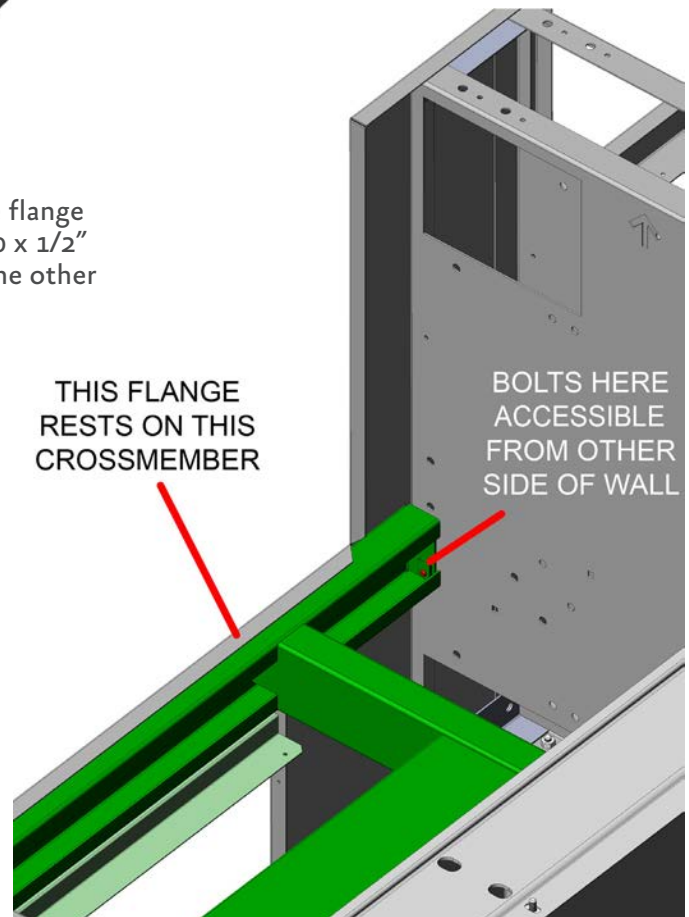



3. This cutaway view shows additional fastener locations for the crossmember. Note the "L" for left side. Tighten all these bolts.

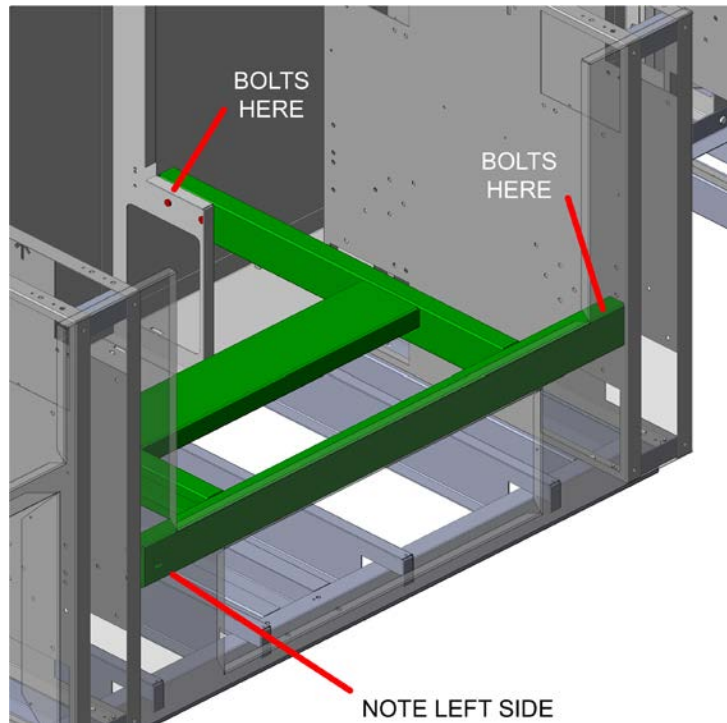

4. The Outdoor Living Suite for Kamado Grill features a deep alcove for the appliance which must be set in place as shown below, then the plywood sub-structure must be secured, then the large stone countertop. Get assistance from another person to help lift the top and position correctly.

Use coated or stainless steel 1/2" long wood screws where needed to secure the vertical walls and alcove to the underside of the plywood, using the small holes provided (similar to step 3 on pg. 30). Tighten any remaining bolts underneath and return to step 5 on pg. 18 to complete the procedure.

