



## STANDARD FEATURES



## BUILT-IN GRILLS

- Available in 30", 36", and 42" widths
- Horizon™ hood with spring-assisted hinges to hold at desired heights\*
- Motion activated Stadium™ halogen under-hood lighting\*
- Multi-purpose built-in ceramic infrared rotisserie / searing / finishing burner\* from 12,000 to 18,000 Btu/hour (depending on model) with simple touch on function
- High performance 321SS Trellis™ tubular burner at 25,000 Btu/hour each\*
- 5/16" thick DiamondCut™ lasered in-house stainless steel grate\*

- High performance variable ceramic infrared sear burner at 25,000 Btu/hour each
- Symmetrical flip to clean radiant tray with monogrammed ceramic briquettes\*
- 525 square inch total grilling surface for 30" model. 653 square inch total grilling surface for 36" model. 782 square inch total grilling surface for 42" model.
- Warming rack - 189 square inches for the 30", 236 square inches for the 36" and 282 square inches for the 42" unit.
- Concealed chain driven whisper quiet rotisserie motor system with a single speed, 6 rpm, 50 in-lbs motor
- Marquise™ accented control panel and hood handle with commercial grade end caps
- 5/16" thick DiamondCut™ lasered in-house stainless steel warming rack with 3 vertical positions. Concealed storage when not in use.
- Hot surface ignition system with lighting assist function
- Lifetime warranty on welded body, DiamondCut™ grates and warming racks, Trellis™ burners, variable sear burners, and rotisserie burner
- Infinite position monogrammed removable smoker and handle for wood chips or smoker pellets
- Heavy gauge welded body construction
- LED front control panel lighting with simple touch on function
- Monogrammed temperature gauge with cooking zone markings
- Stainless steel removable drip tray for ease of cleaning
- Zamak die-cast knobs, burner indicators and bezels
- Porcelain broiling pan with stainless steel rotisserie spit and forks

Laser Cut Stainless Steel Grate - 5/16" thick



Under-Hood Lighting



Multi-Purpose Ceramic Infrared Rotisserie



36" Model Shown

## OPTIONS & ACCESSORIES

- Natural Gas (NG) or Liquid Propane (LP)
- Twelve (12) Hestan signature color finishes
- High altitude kit
- Gas conversion kits (NG/LP)
- Carbon Fiber Vinyl Cover

\* = patent pending

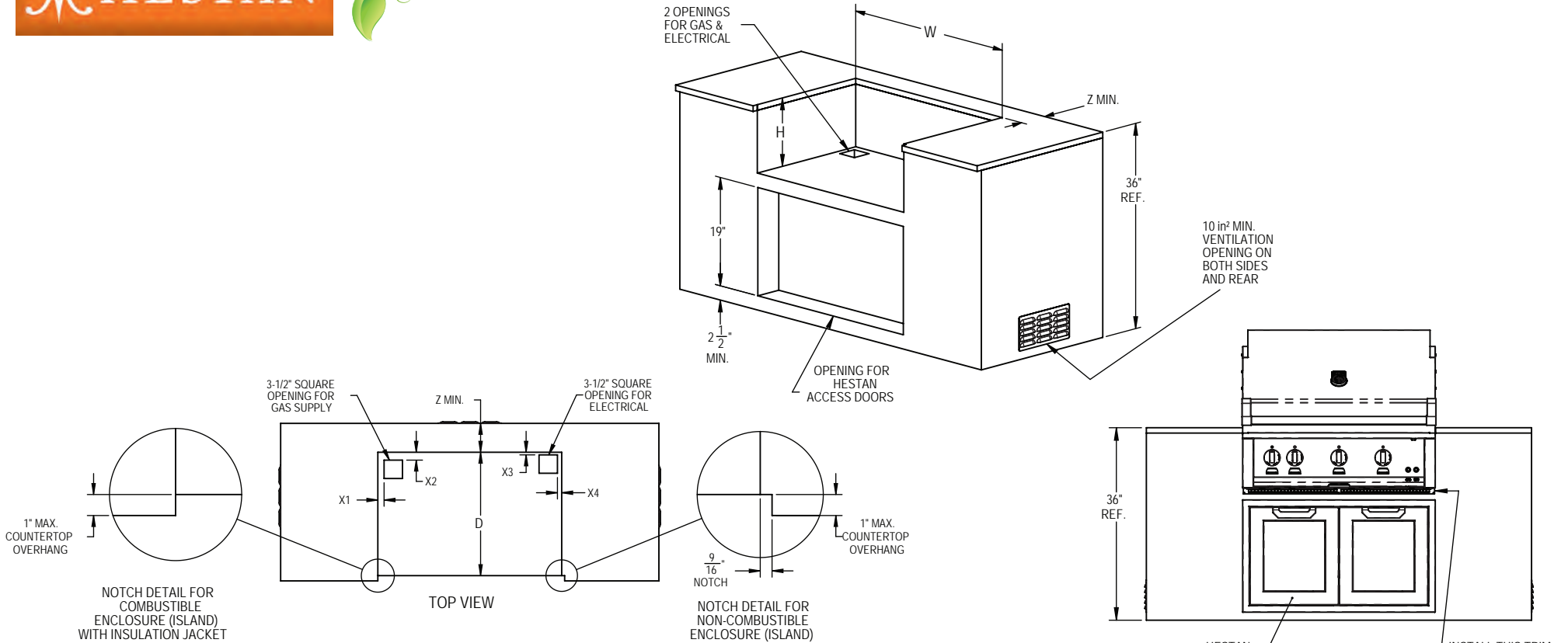
**INSULATED JACKET**

Model Number	Description	W (in.)	D (in.)	H (in.)	X1 (in.)	X2 (in.)	X3 (in.)	X4 (in.)	Z (in.)
AGIJ30	Insulated Jacket, 30"	35	25 - <sup>1</sup> / <sub>8</sub>	12 - <sup>13</sup> / <sub>16</sub>	4 - <sup>3</sup> / <sub>16</sub>	3 - <sup>1</sup> / <sub>8</sub>	1 - <sup>1</sup> / <sub>2</sub>	3 - <sup>13</sup> / <sub>16</sub>	3 - <sup>7</sup> / <sub>8</sub>
AGIJ36	Insulated Jacket, 36"	41	25 - <sup>1</sup> / <sub>8</sub>	12 - <sup>13</sup> / <sub>16</sub>	4 - <sup>3</sup> / <sub>16</sub>	3 - <sup>1</sup> / <sub>8</sub>	1 - <sup>1</sup> / <sub>2</sub>	3 - <sup>13</sup> / <sub>16</sub>	3 - <sup>7</sup> / <sub>8</sub>
AGIJ42	Insulated Jacket, 42"	47	25 - <sup>1</sup> / <sub>8</sub>	12 - <sup>13</sup> / <sub>16</sub>	4 - <sup>3</sup> / <sub>16</sub>	3 - <sup>1</sup> / <sub>8</sub>	1 - <sup>1</sup> / <sub>2</sub>	3 - <sup>13</sup> / <sub>16</sub>	3 - <sup>7</sup> / <sub>8</sub>

**GAS REQUIREMENTS :** 1/2" NPT gas connection.

Minimum gas supply is 7" water column for natural gas and 11" for propane. Operating pressure at the manifold is 4" water column for natural gas and 10" for propane. All units require a regulated gas supply.

**ELECTRICAL REQUIREMENTS :**

120V, 60Hz, 6 amps



Hestan Outdoor products are approved for outdoor use only. Hestan Commercial Corporation reserves the right to change materials and specifications without notice. Specify type of gas when ordering.

Built - In Models	Description	Cutout Dimensions								Total Btu's
		W (in.)	D (in.)	H (in.)	X1 (in.)	X2 (in.)	X3 (in.)	X4 (in.)	Z (in.)	
G_BR30-NG / -LP	30" Grill Built-in	29	23 - <sup>1</sup> / <sub>2</sub>	12	1 - <sup>3</sup> / <sub>16</sub>	1 - <sup>1</sup> / <sub>2</sub>	1/4	13/16	5 - <sup>1</sup> / <sub>2</sub>	62000
G_BR36-NG / -LP	36" Grill Built-in	35	23 - <sup>1</sup> / <sub>2</sub>	12	1 - <sup>3</sup> / <sub>16</sub>	1 - <sup>1</sup> / <sub>2</sub>	1/4	13/16	5 - <sup>1</sup> / <sub>2</sub>	89000
G_BR42-NG / -LP	42" Grill Built-in	41	23 - <sup>1</sup> / <sub>2</sub>	12	1 - <sup>3</sup> / <sub>16</sub>	1 - <sup>1</sup> / <sub>2</sub>	1/4	13/16	5 - <sup>1</sup> / <sub>2</sub>	118000

\_ = specify burner configuration    A= all Trellis Burners    M= Sear and Trellis Burners    S= all Sear Burners



### STANDARD FEATURES

- Available in 30", 36", and 42" widths
- Marquise™ paneled fold-down side shelves for extra work space
- 2-door or 1-door + 2-drawer configurations
- Recessed Marquise™ accented panels with commercial grade handles

Soft Close Hinges



- Full extension drawer slides with soft close capability
- Soft close door hinges with alignment adjustability
- Commercial grade gray casters with 360 degrees of maneuverability for the smoothest cart movement
- Standard pullout tray with slides to store LP gas tank

Pull Out Tank Shelf



Colors Available



Side Shelf attached to Side Burner



Grill Head Sold Separately  
Showing cart model GCR36

### OPTIONS & ACCESSORIES

- Optional 12" side mount double side burner with DiamondCut™ grate and stainless steel cover with 20,000 Btu/hour brass front burner and 10,000 Btu/hour brass rear burner
- Twelve (12) Hestan signature color finishes
- Carbon Fiber Vinyl Cover



### 30" Tower Cart Options



### 36" Tower Cart Options



### 42" Tower Cart Options



Shown in Optional Color

### All Models Shown With Side Burners



Shown in Optional Color

All Models	Description	Overall Dims			H1 (in.) cart only	with Side Burner (W in.)	w/ Side Burner and Side Shelf (W in.)
		W(in.)	D(in.)	H(in.)			
GCD30	30" Double Door Tower Cart	36-3/4	29-3/8	53-9/16	35-1/8	45-3/8	48-3/4
GCR30	30" Door and Drawer Tower Cart	36-3/4	29-3/8	53-9/16	35-1/8	45-3/8	48-3/4
GCD36	36" Double Door Tower Cart	42-3/4	29-3/8	53-9/16	35-1/8	51-3/8	54-3/4
GCR36	36" Door and Drawer Tower Cart	42-3/4	29-3/8	53-9/16	35-1/8	51-3/8	54-3/4
GCR42	42" Door and Drawer Tower Cart	48-3/4	29-3/8	53-9/16	35-1/8	57-3/8	60-3/4

Hestan Outdoor products are approved for outdoor use only. Hestan Commercial Corporation reserves the right to change materials and specifications without notice.

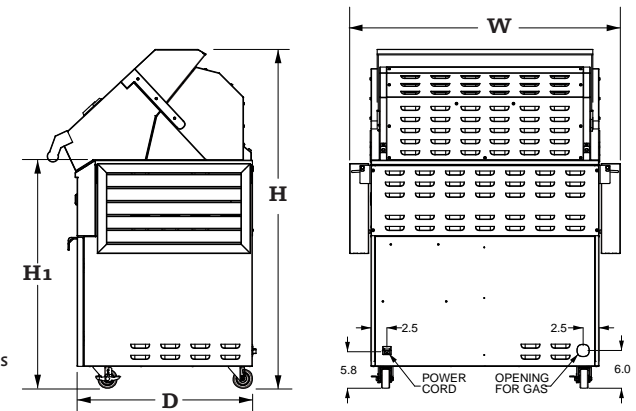



## STANDARD FEATURES

# HESTAN

## DELUXE GRILLS

- Horizon™ hood with spring-assisted hinges to hold at desired heights\*
- Motion activated Stadium™ halogen under-hood lighting\*
- Multi-purpose built-in ceramic infrared rotisserie / searing / finishing burner\* from 12,000 to 18,000 Btu/hour (depending on model) with simple touch on function
- High performance 321SS Trellis™ tubular burner at 25,000 Btu/hour each\*
- 5/16" thick DiamondCut™ lasered in-house stainless steel grate\*

- High performance variable ceramic infrared sear burner at 25,000 Btu/hour each
- Symmetrical flip to clean radiant tray with monogrammed ceramic briquettes\*
- 525 square inch total grilling surface for 30" model. 653 square inch total grilling surface for 36" model. 782 square inch total grilling surface for 42" model.
- Available in 48", 54", and 60" widths
- 12" built-in double side burners or stainless steel worktop with storage drawer
- Marquise™ accented panels, side cart handle, and commercial end caps
- Flip-down front panel with commercial grade handle for access to gas tank and pullout tool storage drawer
- Standard pullout tray for LP gas tank through rear access door
- Left side Marquise™ paneled fold-down side shelf for extra work space
- Extra-large gray front wheels and commercial grade gray casters with 360 degrees of maneuverability for the smoothest cart movement

Laser Cut Stainless Steel Grate - 5/16" thick



Under-Hood Lighting



Multi-Purpose Ceramic Infrared Rotisserie



Tool Storage Drawer



Pull Out Tank Shelf

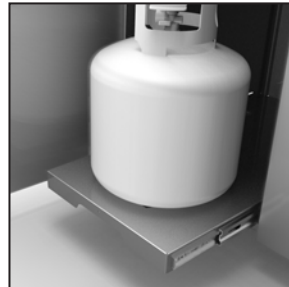

Model number as shown  
GABR36CX2-LP

- Double side burners: 20,000 Btu/hour brass front burner and 10,000 Btu/hour brass rear burner
- 5/16" thick DiamondCut™ grate
- Sealed burner bowl with drain tube for easy cleaning
- Electronic spark ignition system with re-ignition capability
- LED lighting on front control panel
- 120V, 60Hz, 7 amp
- Please refer to Built-In Grills and Side Burner spec sheets for additional features

\* = patent pending

DELUXE GRILLS



## Shown with side burner

with 30" grill head



with 36" grill head



with 42" grill head



Colors Available



Shown in optional color

## Shown with worktop and storage drawer



Shown in optional color

### OPTIONS & ACCESSORIES

- Natural Gas (NG) or Liquid Propane (LP)
- Twelve (12) Hestan signature color finishes
- High Altitude Kit
- Gas conversion kits (NG/LP)
- Carbon Fiber Vinyl Cover

All Models	Description	Overall Dims			Total Btu's
		W(in.)	D(in.)	H(in.)	
G_BR30CX-NG / -LP	48" Freestanding Deluxe Grill with Worktop / Drawer	48-3/4	32-1/2	53-9/16	62000
G_BR30CX2-NG / -LP	48" Freestanding Deluxe Grill with Double Side Burner	48-3/4	32-1/2	53-9/16	92000
G_BR36CX-NG / -LP	54" Freestanding Deluxe Grill with Worktop / Drawer	54-3/4	32-1/2	53-9/16	89000
G_BR36CX2-NG / -LP	54" Freestanding Deluxe Grill with Double Side Burner	54-3/4	32-1/2	53-9/16	119000
G_BR42CX-NG / -LP	60" Freestanding Deluxe Grill with Worktop / Drawer	60-3/4	32-1/2	53-9/16	118000
G_BR42CX2-NG / -LP	60" Freestanding Deluxe Grill with Double Side Burner	60-3/4	32-1/2	53-9/16	148000

\_ = specify burner configuration

A = all Trellis Burners M = Sear and Trellis Burners S = all Sear Burners

Hestan Outdoor products are approved for outdoor use only. Hestan Commercial Corporation reserves the right to change materials and specifications without notice. Specify type of gas when ordering.

**GAS REQUIREMENTS:** 1/2" NPT gas connection. Minimum gas supply is 7" water column for natural gas and 11" for propane. Operating pressure at the manifold is 4" water column for natural gas and 10" for propane. All units require a regulated gas supply.

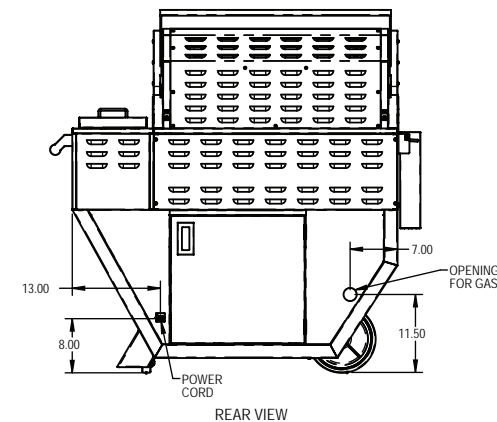



### STANDARD FEATURES

- Single or double side sealed burner(s) configurations
- Double side burners: 20,000 Btu/hour brass front burner and 10,000 Btu/hour brass rear burner
- Single side burner: 20,000 Btu/hour brass sealed burner
- 5/16" thick DiamondCut™ grate

Lasered Stainless Steel Grate – 5/16" thick



Bright LED Lighting



Sealed Burner Bowl

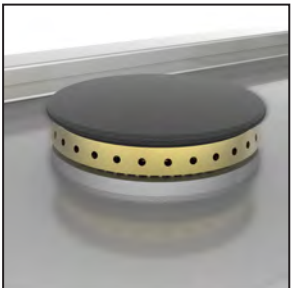

Stainless Cover

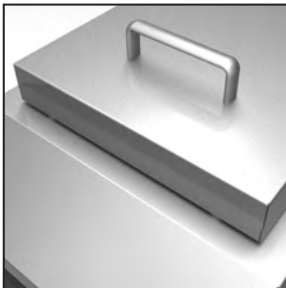

- Sealed burner bowl with drain tube for easy cleaning
- Electronic spark ignition system with re-ignition capability
- LED lighting on front control panel
- Heavy gauge welded body construction
- Stainless steel drip tray for ease of cleaning
- Stainless steel top cover
- Double side burner is mountable to Tower Carts
- 120V, 60Hz, 1 amp



Model shown AGB121-LP

Model shown AGB122-LP

### OPTIONS & ACCESSORIES

- Natural Gas (NG) or Liquid Propane (LP)
- Twelve (12) Hestan signature color finishes
- High altitude kit
- Gas conversion kits (NG/LP)
- Carbon Fiber Vinyl Cover



SHOWN ATTACHED TO TOWER CART

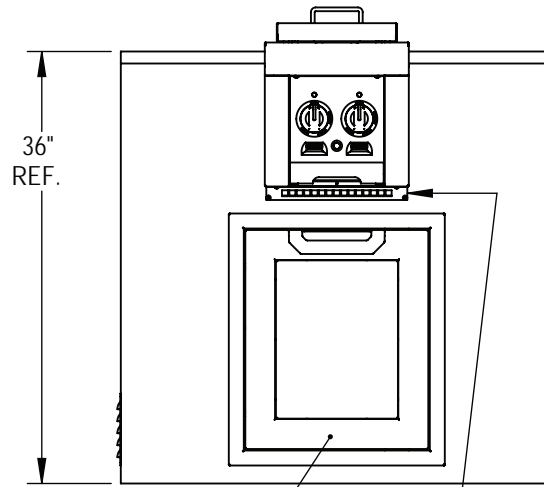

HESTAN ACCESS DOOR (SOLD SEPARATELY)

INSTALL THIS TRIM AFTER SIDE BURNER INSTALLATION

3-1/2" X 5-1/2" OPENING FOR GAS SUPPLY & ELECTRICAL

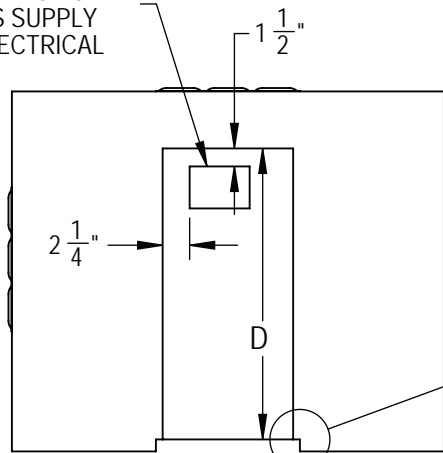

TOP VIEW

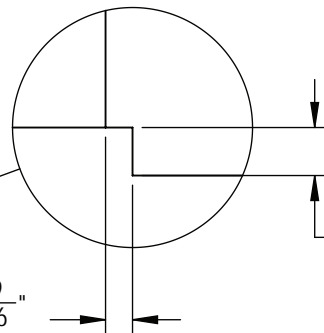

9/16" NOTCH

1" MAX. COUNTERTOP OVERHANG

LAYOUT FOR NON-COMBUSTIBLE ENCLOSURE (ISLAND)

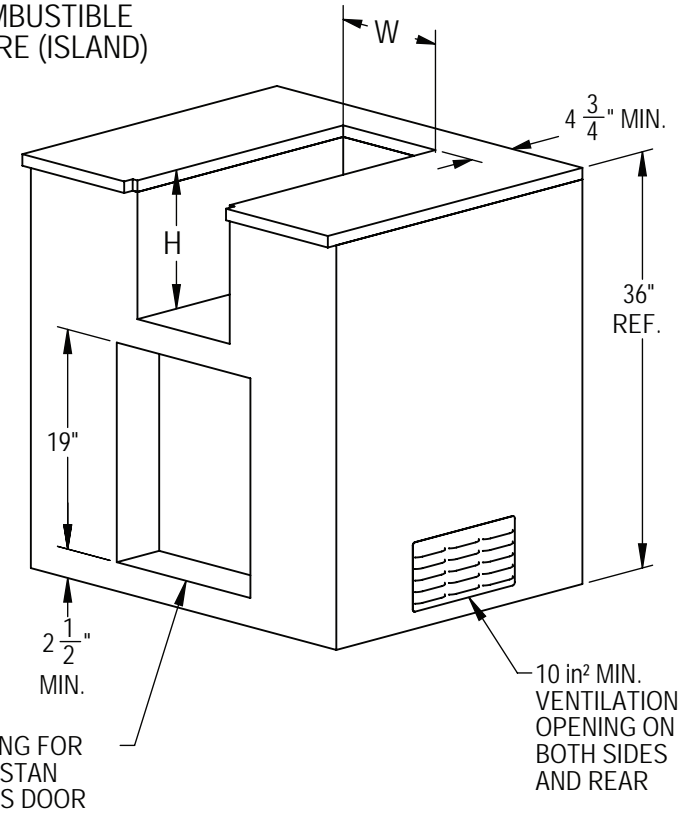

OPENING FOR HESTAN ACCESS DOOR

10 in<sup>2</sup> MIN. VENTILATION OPENING ON BOTH SIDES AND REAR

**ELECTRICAL REQUIREMENTS :** 120V, 60Hz, 6 amps

**GAS REQUIREMENTS :** 1/2" NPT gas connection. Minimum gas supply is 7" water column for natural gas and 11" for propane. Operating pressure at the manifold is 4" water column for natural gas and 10" for propane. All units require a regulated gas supply.

Hestan Outdoor products are approved for outdoor use only. Hestan Commercial Corporation reserves the right to change materials and specifications without notice. Specify type of gas when ordering.



All Models	Description	Cutout Dimensions			Total Btu's
		W(in.)	D(in.)	H(in.)	
AGB121-NG / -LP	Single Side Burner, Built-in, 12"	11	13-7/8	12	20,000
AGB122-NG / -LP	Double Side Burner, Built-In or Cart-Attached 12"	11	24-1/4	12	30,000





## REFRIGERATION PRODUCTS



### 15" Ice Machine

- Stainless steel front and sides
- 33-1/2" H x 14-7/8" W x 22-5/8" D
- Up to 22 lbs of total ice storage capacity
- Up to 55 lbs of ice produced per 24 hours
- Air-cooled, self contained, built-in storage bin
- Produces top hat ice cubes
- Front in, front out airflow
- Heavy duty insulation
- Adjustable leveling legs
- Left or right hinged models
- NEMA 5-15 plug
- Easily disassembled water circuit for easy cleaning
- R-134a refrigerant
- UL and NSF certified for outdoor use
- Optional drain pump



### 24" Beer Dispenser

- Stainless steel front, sides, and interior
- 34-1/4" H x 23-7/8" W x 24" D
- 5.2 cubic ft of total storage capacity
- Fits one 1/4 barrel, one slim 1/4 slim barrel, or two 1/6 barrels (pony kegs or 5 gal.)
- Single or double faucet
- CO2 tank, hoses, and fittings
- Door lock
- LED interior lighting
- Heavy duty insulation
- Temperature control from 33F to 42F
- Digital temperature display
- Variable speed compressor
- Front-vented, forced-air refrigeration system
- Convertible door design allows all doors the ability to be converted to wood overlay from stainless steel
- Zero-clearance hinging
- Adjustable leveling legs
- Left or right hinged models
- GFI electric plug
- UL certified for outdoor use
- Optional Caster Kit



### 24" Dual Zone Refrigerator with Wine

- Stainless steel front, sides, & interior
- Solid stainless steel or glass front door (Low E, UV-coated glass provides industry leading insulation & protection)
- 34-1/4" H x 23-7/8" W x 24" D
- 5.0 cubic ft of total storage capacity
- Two (2) full-extension pull-out wine storage shelves in upper zone, one (1) full extension pull-out shelf in lower zone
- Door lock
- LED interior lighting
- Heavy duty insulation
- Temperature control from 33°F – 42°F (Lower Refrigerator Zone), 45°F – 65°F (Upper Wine Zone)
- Digital temperature display
- Variable speed compressor
- Front-vented, forced-air refrigeration system
- Convertible door design allows all doors the ability to be converted to wood overlay from stainless steel
- Zero-clearance hinging
- Adjustable leveling legs
- Left or right hinged models
- GFI electric plug
- UL certified for outdoor use
- Optional Caster Kit



### 24" Refrigerator

- Stainless steel front, sides, & interior
- 34-1/4" H x 23-7/8" W x 24" D
- 5.2 cubic ft of total storage capacity
- Door lock
- LED interior lighting
- Adjustable, full-extension pull-out shelves
- Heavy duty insulation
- Temperature control from 33F to 42F
- Digital temperature display
- Variable speed compressor
- Front-vented, forced-air refrigeration system
- Convertible door design allows all doors the ability to be converted to wood overlay from stainless steel
- Zero-clearance hinging
- Adjustable leveling legs
- Left or right hinged models
- GFI electric plug
- UL certified for outdoor use
- Optional Caster Kit



### 24" Refrigerated Drawers

- Stainless steel front, sides, & interior
- 34-1/4" H x 23-7/8" W x 24" D
- 5.2 cubic ft of total storage capacity
- Drawers with lock
- LED interior lighting
- Heavy duty full extension drawer slides
- Heavy duty insulation
- Temperature control from 33F to 42F
- Digital temperature display
- Variable speed compressor
- Front-vented, forced-air refrigeration system
- Convertible door design allows all doors the ability to be converted to wood overlay from stainless steel
- Adjustable leveling legs
- GFI electric plug
- UL certified for outdoor use
- Optional Caster Kit

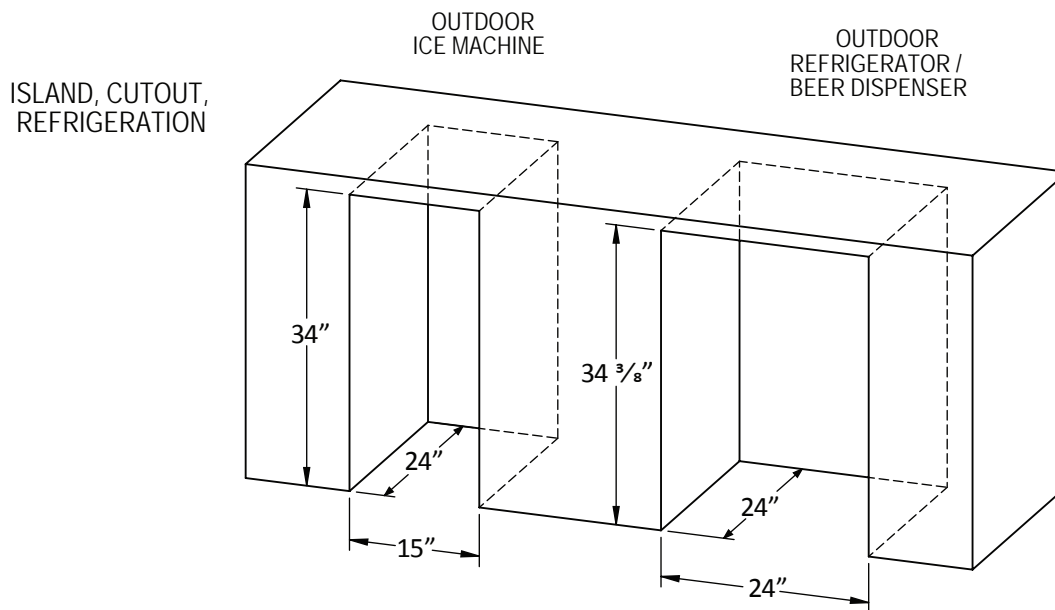

NOTE: See outdoor beer dispenser manual for detailed installation information and faucet tower cutout dimensions.

Models	Description	Electrical Requirements
GRS_24	24" Outdoor Refrigerator, Solid Door with Lock	115V, 60Hz., 1 Phase, 2.3 amps
GRR24	24" Outdoor Refrigerator Drawers with Lock	115V, 60Hz., 1 Phase, 2.3 amps
GRWS_24	24" Outdoor Dual Zone Refrigerator w Wine, Solid Door with Lock	115V, 60Hz., 1 Phase, 2.3 amps
GRWC_24	24" Outdoor Dual Zone Refrigerator w Wine, Glass Door with Lock	115V, 60Hz., 1 Phase, 2.3 amps
GFDS_241	24" Outdoor Single Faucet Beer Dispenser, Solid Door with Lock	115V, 60Hz., 1 Phase, 2.3 amps
GFDS_242	24" Outdoor Double Faucet Beer Dispenser, Solid Door with Lock	115V, 60Hz., 1 Phase, 2.3 amps
GIM_15	15" Outdoor Ice Machine	120V, 60Hz, 3.4 amps

\_ = Specify (L) or (R) for Left or Right Hinge model

Hestan Outdoor products are approved for outdoor use only. Hestan Commercial Corporation reserves the right to change materials and specifications without notice.



All Products



Ice Machine Only



### ACCESS DOORS

*Single and Double Access Doors*

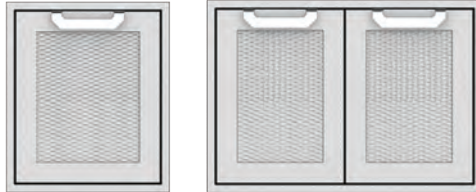

- Available in 18", 24", 30", 36", and 42" widths
- Heavy gauge welded body construction
- Recessed Marquise™ accented panels with commercial grade handles
- Soft close door hinges with alignment adjustability

### STORAGE

*Drawers 30", 36" and 16" Double*

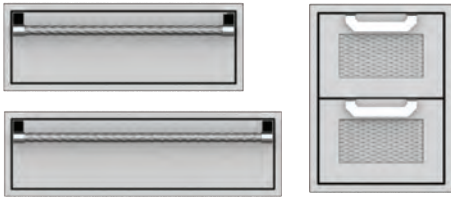

*Storage Cabinets 30", 36", or 42" Double Door or Door Drawer Combo*



*Magnetic Sealed Pantry Storage 36" only*

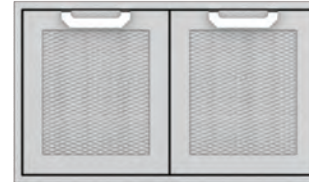

- Heavy gauge welded body construction
- Motion activated illumination
- Recessed Marquise™ accented panels with commercial grade handles
- Soft close door hinges with alignment adjustability

### RECYCLE, CLEAN-UP & TRASH

*Trash and Recycle Center Storage Drawer*



- Available in 20" width
- Heavy gauge welded body construction
- Slide out trash and recycle bins that are easily removable for emptying and cleaning
- Full extension slides
- Recessed Marquise™ accented panel with commercial grade handle

*Paper Towel Dispenser*



- Can be mounted horizontally or vertically (left or right hinged)
- Removable paper towel holder - fits standard paper towel roll
- Heavy gauge welded body construction
- Recessed Marquise™ accented panel with commercial grade handle

*Countertop Trash Chute*

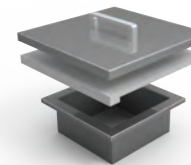

- Heavy gauge welded body construction
- Complimentary to Trash Center
- Easy disposal without pulling out the Trash Center door
- Stainless steel top cover with handle
- Commercial grade cutting board that slides for easy access to chute

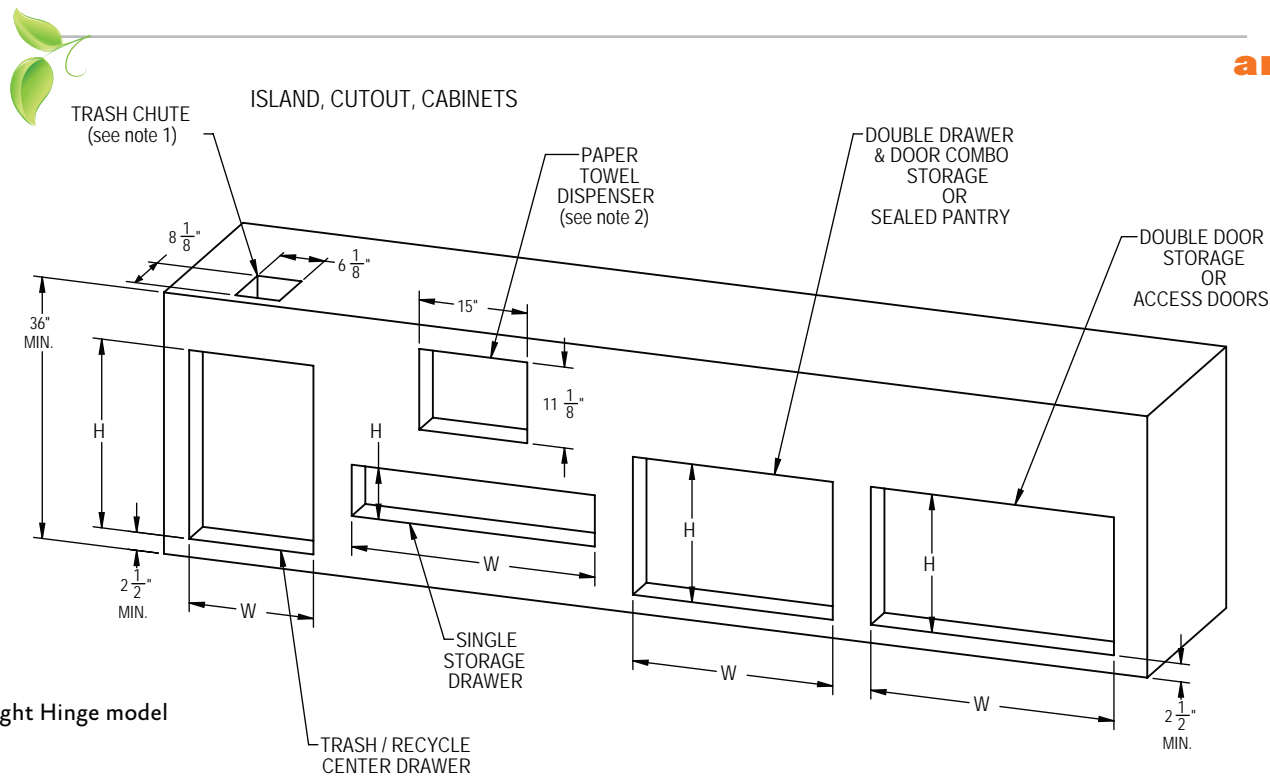

**NOTES:**

- 1) Trash Chute AGTC cutout depends on type of countertop used. Please refer to installation instructions for details.
- 2) Paper Towel Dispenser AGPTD16 can be installed in 3 different orientations using these cutout dimensions. Please refer to installation instructions for details.

\_\_ = specify (L) or (R) for Left or Right Hinge model  
 XX = width needed

Built - In Models	Description	Product Width Options		Cutout Dimensions		
		W (in.)	W (in.)	D (in.)	H (in.)	
AGAD__xx	Single Access Door , with Marquise accent panel	18" or 24"	15 <sup>-7/8"</sup> or 21 <sup>-7/8"</sup>	n/a	19	
AGADxx	Double Access Doors , with Marquise accent panel	30", 36" or 42"	27 <sup>-7/8"</sup> , 33 <sup>-7/8"</sup> or 39 <sup>-7/8"</sup>	n/a	19	
AGSDxx	Double Storage Doors , with Marquise accent panel	30", 36" or 42"	27 <sup>-7/8"</sup> , 33 <sup>-7/8"</sup> or 39 <sup>-7/8"</sup>	23 <sup>-3/8"</sup>	19	
AGSRxx	Single Storage Drawer , all stainless front with Marquise accent handle	30" or 36"	27 <sup>-7/8"</sup> or 33 <sup>-7/8"</sup>	23 <sup>-3/8"</sup>	8 <sup>-7/8"</sup>	
AGDR16	Double Drawers , with Marquise accent panel	16"	13 <sup>-11/16"</sup>	23 <sup>-3/8"</sup>	19	
AGSDRxx	Double Drawer and Storage Door Combination w/ Marquise accent panel	30", 36" or 42"	27 <sup>-7/8"</sup> , 33 <sup>-7/8"</sup> or 39 <sup>-7/8"</sup>	23 <sup>-3/8"</sup>	19	
AGLP36	Double Sealed Pantry Storage Doors, with Marquise accent panel	36"	33 <sup>-7/8"</sup>	24 <sup>-13/16"</sup>	18 <sup>-3/4"</sup>	
AGTRC20	Trash and Recycle Center Storage Drawer, with Marquise accent panel	20"	17 <sup>-1/4"</sup>	24 <sup>-1/2"</sup>	25 <sup>-3/4"</sup>	
AGTC	Countertop Trash Chute with Cutting Board and Cover	-	6 <sup>-1/8"</sup>	8 <sup>-1/8"</sup>	n/a	
AGPTD16	Paper Towel Dispenser, with Marquise accent panel	16"	11 <sup>-1/8"</sup>	10 <sup>-1/8"</sup>	15	

Hestan Outdoor products are approved for outdoor use only. Hestan Commercial Corporation reserves the right to change materials and specifications without notice.