



INDOOR COOKING

All-Gas Range
KRG

Use & Care Manual

 HESTAN

▲WARNING

IF THE INFORMATION IN THIS MANUAL IS NOT FOLLOWED EXACTLY, A FIRE OR EXPLOSION MAY RESULT CAUSING PROPERTY DAMAGE, PERSONAL INJURY, OR DEATH.

Do not store or use gasoline or other flammable vapors and liquids in the vicinity of this or any other appliance.

WHAT TO DO IF YOU SMELL GAS:

1. Do not try and light any appliance.
2. Do not touch any electrical switch.
3. Do not use any phone in your building.
4. Immediately call your gas supplier from a neighbor's phone. Follow the gas supplier's instructions.
5. If you cannot reach your gas supplier, call the fire department.

Installation and service must be performed by a qualified installer, service agency, or the gas supplier.

READ THESE INSTRUCTIONS CAREFULLY AND COMPLETELY BEFORE INSTALLING OR USING YOUR APPLIANCE TO REDUCE THE RISK OF FIRE, BURN HAZARD, OR OTHER INJURY. KEEP THIS MANUAL FOR FUTURE REFERENCE.

SAFETY DEFINITIONS

▲WARNING

THIS INDICATES THAT DEATH OR SERIOUS INJURY MAY OCCUR AS A RESULT OF NOT OBSERVING THIS WARNING.

▲CAUTION

THIS INDICATES THAT MINOR OR MODERATE INJURY MAY OCCUR AS A RESULT OF NOT OBSERVING THIS WARNING.

NOTICE

THIS INDICATES THAT DAMAGE TO THE APPLIANCE OR PROPERTY MAY OCCUR AS A RESULT OF NOT OBSERVING THIS WARNING.

INSTALLER: LEAVE THIS MANUAL WITH THE OWNER OF THE APPLIANCE.
HOMEOWNER: RETAIN THIS MANUAL FOR FUTURE REFERENCE.

▲WARNING

TIP OVER HAZARD

A child or adult can tip over a range and be killed.

Check installation of the anti-tip device per the Installation Manual.
Do not operate the range without this device in place.

Check engagement of anti-tip device if range is moved, such as when cleaning behind the unit.

To check engagement, carefully tip the range forward while pulling from the rear of the unit. The range should not move more than 1 inch [2.5cm].

Failure to follow these instructions can result in death or serious burns to children and adults.

To reduce the risk of burns, do not move this appliance while hot.



Message from Hestan

Hestan's award-winning culinary innovations and purpose-built features reinvented the restaurant kitchen and redefined culinary experience in some of America's most acclaimed restaurants. Hestan now takes this performance from the back of the house and puts it front and center in yours. Thoughtfully designed and meticulously built, Hestan will serve you beautifully for years to come.

Hestan is the only residential brand born from the dreams and demands of professional chefs. From ranges to refrigeration, every detail is designed to deliver the performance and reliability expected in a restaurant – now available for you.

We appreciate you choosing Hestan, and we promise to deliver the very best to you.

Welcome to Hestan



TABLE OF CONTENTS

3	SAFETY PRECAUTIONS - BEFORE YOU BEGIN
8	MODEL NUMBERS
9	RATING LABEL
9	REGULATORY / CODE REQUIREMENTS
10	GETTING STARTED WITH YOUR APPLIANCE
16	USING THE RANGETOP
18	USING THE GRIDDLE (<i>SOME MODELS</i>)
19	USING THE OVEN
22	OVEN CONTROLS
28	ADDITIONAL ITEMS
29	CARE & MAINTENANCE
33	TROUBLESHOOTING GUIDE
34	PARTS LIST
34	SERVICE
34	LIMITED WARRANTY

SAFETY PRECAUTIONS - BEFORE YOU BEGIN

When properly cared for, your Hestan appliance will provide safe, reliable service for many years. When using this appliance, basic safety practices must be followed as outlined below.

INSTALLER: Please leave these Installation Instructions with the owner.

OWNER: Please retain these Installation Instructions for future reference.

This range is designed for residential use only. It is NOT designed for installation in manufactured (mobile) homes or recreational park trailers. Do NOT install this range outdoors.

⚠ WARNING

ELECTRICAL SHOCK HAZARD

Disconnect power before installing or servicing appliance. Before turning power ON, be sure all controls are in the OFF position. Failure to do so can result in electrical shock or death.

ELECTRICAL GROUNDING

This appliance must be grounded. Grounding reduces the risk of electric shock in the event of a short circuit. Read the ELECTRICAL CONNECTIONS section of the Installation Manual for complete instructions.

This appliance is equipped with a 3-prong grounding plug for your protection against shock hazard and should be directly plugged into a properly grounded receptacle. Do not cut or remove the grounding prong from this plug.



SAFETY PRECAUTIONS - BEFORE YOU BEGIN (CONTINUED)

ELECTRICAL SUPPLY

This appliance must be connected to a dedicated circuit, 120 VAC, Single Phase, 60 Hz, with a current rating as shown in the model number listing on page 8. Have the installer show you where the electric circuit breaker is located so you know how to shut off the power to this appliance. It is the responsibility of the user to have the appliance connected by a licensed electrician in accordance with all local codes, or in the absence of local codes, in accordance with the National Electrical Code. Read the ELECTRICAL CONNECTIONS section of the Installation Manual for complete details.

GAS SUPPLY

A gas shut-off valve must be located in an easily accessible location for servicing of the range. Make sure all users of the range know where this shut-off is located, and how to shut off the gas.

The type of gas should be verified prior to installation and operation of this appliance. It is the responsibility of the user to have the appliance connected by a licensed plumber in accordance with all local codes, or in the absence of local codes, in accordance with the National Fuel Gas Code.

When connecting to LP gas, verify the tank is equipped with its own high pressure regulator. The pressure of the gas supplied to the appliance must be 11-14 inch WC [2.74-3.48 kPa]. Consult the Installation Manual for details on gas type, gas pressure, connection and leak testing instructions, etc.

Read the GAS CONNECTIONS section of the Installation Manual for complete details.

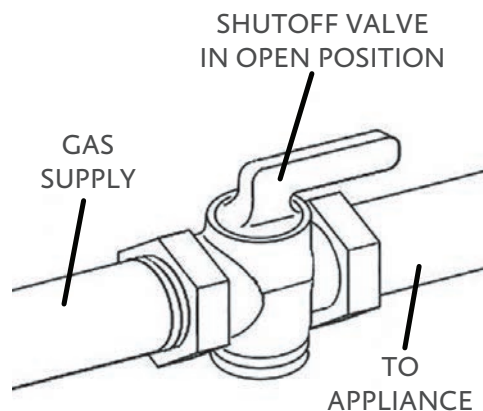

CONVERSION KITS

In the event your Hestan appliance needs to be converted from NG to LP, or vice-versa, you will need to contact Hestan Customer Service to arrange a service call. This conversion should only be performed by a qualified technician.

HIGH ALTITUDE KITS

If you live in a high altitude area, 2,000 ft. [610 m] or more above sea level, your appliance may require different orifices for proper combustion and performance. You will need to contact Hestan Customer Service to arrange a service call. High Altitude kits must be installed by a qualified technician. Please have your model and serial number information ready when you call.

BACKGUARD

Your Hestan range is supplied at the factory with an Island Trim backguard. See Table 1 in the APPENDIX section of the Installation Manual for other backguard options available from your Hestan dealer, or visit www.hestanhome.com. Selection of the appropriate backguard depends on the installation location and adjacent materials, and the type of vent hood to be used. Installation instructions are included with the backguard kit. A LOW OR TALL BACKGUARD IS REQUIRED WHEN INSTALLING THE RANGE AGAINST A COMBUSTIBLE SURFACE - THE ISLAND TRIM IS NOT SUITABLE.

▲ CAUTION

The top of the backguard serves as an exhaust for the oven when in operation, and as an exhaust vent to remove heat from under the rangetop section of the range as well. DO NOT BLOCK or obstruct the top of the backguard. DO NOT touch the top of the backguard during appliance operation as it may get hot. Allow sufficient time to cool before touching or cleaning this area. DO NOT position plastic or other heat-sensitive items nearby which could melt or burn.

SAFETY PRECAUTIONS - BEFORE YOU BEGIN *(CONTINUED)*

VENTILATION REQUIREMENTS

A vent hood is REQUIRED above this appliance. It is strongly recommended that this appliance be installed with a Hestan vent hood. Hestan vent hoods have been matched up to the BTU output of the range. Due to the high heat output of this range, it is very important that the hood and ductwork installation meets local building codes and is installed by a qualified technician.

Do not use a down-draft style ventilation system.

Do not mount a microwave oven/ventilator combination above the range. These types of units do not have sufficient airflow to remove the high heat output of this range and were not tested with this type of appliance.

Consult the Installation Manual for further details.

CONSULT WITH YOUR HESTAN DEALER ON SELECTING THE APPROPRIATE VENT HOOD FOR YOUR HESTAN APPLIANCE.

▲WARNING

IN CASE OF POWER OUTAGE

All the control knobs must be in the OFF position to prevent unintended operation at power up. To ensure customer safety in the event of a power failure, the range will signal an error by blinking the backlights of one or more knobs when the power is restored unless all the knobs are in the OFF position. Set all the knobs to OFF, then resume operation.

DO NOT ATTEMPT TO USE THE RANGE DURING A PROLONGED POWER FAILURE. Although the top burners can be manually lit, they should be used ONLY WHILE BEING ATTENDED BY THE USER. On low burner settings, if the flame were to go out, a dangerous accumulation of gas could result in an explosion.

▲CAUTION

CHILD SAFETY

IT IS THE RESPONSIBILITY OF THE PARENTS OR GUARDIANS TO ENSURE CHILDREN ARE INSTRUCTED IN THE SAFE USE OF THIS APPLIANCE. Do not allow children to use this appliance without adult supervision. Do not allow children to play in or around the appliance, even when not in use. Items of interest to children should not be stored in or on the appliance, in cabinets above, or on the backguard of the appliance. Children climbing on the appliance could be seriously injured.

▲WARNING

BURN HAZARD - All parts of the range can get very hot during operation. The oven door glass and areas surrounding the door get especially hot. Do not let children touch the appliance while in operation. Failure to observe these instructions may result in severe burns or injury.

TECHNICAL SAFETY

Installation and service on this appliance must be performed by a qualified appliance installer, or a Hestan authorized service technician. Do not repair or replace any part of the appliance unless specifically instructed to do so. Defective parts must only be replaced with genuine Hestan parts. Contact Hestan Customer Service for inquiries or to arrange a service call.

The appliance must be disconnected from the power and gas supply during any service or maintenance work.

Do not carry or lift the range by the oven handle. The range can only be lifted from the sides.

SAFETY PRECAUTIONS - BEFORE YOU BEGIN *(CONTINUED)*

USER SAFETY

▲WARNING

BURN HAZARD - All parts of the range can get very hot during operation, especially the oven door glass and areas surrounding the door. Do not touch the appliance while in operation. Failure to observe these instructions may result in severe burns or injury. Use pot holders / gloves to protect yourself when placing food in the oven, adjusting the racks, etc.

The broil burner is in the top of the oven cavity, and the bake burner is hidden beneath the floor of the oven cavity. These burners may be hot, even though they are not glowing. During or after cooking, allow sufficient time for all surfaces to cool.

Use only dry or heat-resistant pot holders / gloves. Using moist or damp potholders can result in steam burns. Do not substitute dish towels or similar items for potholders. These items could come in contact with hot surfaces and ignite.

Avoid wearing loose-fitting garments or long sleeves while cooking. They could ignite. For personal safety, wear proper apparel while using the appliance. Some synthetic fabrics are highly flammable and should not be worn while cooking.

Open the oven door slowly to allow heat and steam to escape before placing or removing food from the oven. Keep your face away from the opening to avoid injury.

▲WARNING

For safety considerations, NEVER use this appliance as a space heater to heat or warm the room. Doing so may result in carbon monoxide poisoning and overheating of the oven.

Do not use the oven as a storage space. The high temperatures could also ignite flammable objects nearby.

▲WARNING

NEVER cover any slots, holes, or passages in the oven bottom or cover an entire oven rack with materials such as aluminum foil. Doing so blocks air flow through the oven and may cause carbon monoxide poisoning. Aluminum foil linings may also trap heat, causing a fire hazard. Do not use aluminum foil to line the surface burners. Doing so may result in a risk of electric shock, or fire.

Do not allow anyone to climb, stand, step on, lean against, or sit on any part of the appliance, especially the oven door. This may result in damage to the appliance, or personal injury.

FIRE SAFETY

To reduce the risk of a fire, do not leave surface burners unattended at high settings. Boil-overs could smother the flames and igniter, which would allow un-burned gas to escape into the room, which could result in an explosion.

Always turn on the ventilation hood when cooking. Clean vent hood grease filters frequently - grease should not be allowed to accumulate on the fan or filters.

Use the appropriate pan size for the burner being used. For safety considerations, adjust the flame size so they do not travel up the sides of the pan.

Keep the appliance area clear and free from combustible materials, gasoline, and other flammable vapors and liquids. NEVER store flammable liquids and materials in, above, or on the range, or near cooking surfaces. Do not obstruct the flow of combustion and ventilation air of the appliance.

ALWAYS have a working smoke detector near the kitchen.

SAFETY PRECAUTIONS - BEFORE YOU BEGIN *(CONTINUED)*

EN

ALWAYS have an appropriate dry-chemical fire extinguisher nearby. Smother fire or flames using the lid of the utensil (pot or pan), a cookie sheet or metal tray. Then shut off the burner. Use an extinguisher, or baking soda if the fire is small and relatively contained. **DO NOT USE WATER ON A GREASE FIRE.** Doing so may result in spreading the fire elsewhere.

NEVER pick up a flaming pan. You may spill the grease on yourself and be severely burned.

If accessible, turn off the ventilation hood during a fire, but do not reach through the flames to do this.

In the event of personal clothing or hair catching fire, drop and roll immediately to smother the flames. Seek medical attention if necessary.

Do not hang articles from any part of the appliance or place anything against the oven door. Some fabrics are highly flammable and could ignite.

IF THE FLAMES DO NOT GO OUT - EVACUATE AND CALL THE FIRE DEPARTMENT.

SAFETY DURING CLEANING

Only clean the appliance as directed in the CLEANING & MAINTENANCE section of this manual.

Do not use a steam cleaner to clean the oven or any part of the range. Steam could penetrate into electrical components and cause a short circuit and/or shock hazard.

Do not use abrasive cleaners, hard objects such as brushes or scrapers, or sharp metal tools to clean the door glass. Scratches could cause the glass to shatter.

Do not rub, disturb or damage the cloth-braided door gasket. If the gasket is damaged, it will need to be replaced.

Do not pour cold water onto hot surfaces inside the oven. The steam could cause serious burns. The sudden temperature change could also distort the metal surfaces inside the oven resulting in cracks in the enamel.

Use only a small toothbrush to clean the burner ports and igniter of the surface burners. Do not insert sharp objects or scratch the burner ports.

Wait until the appliance is completely cool before using any aerosol-type cleaners. Many of these cleaners use flammable propellants which could ignite in the presence of heat.

PROPER USAGE

Do not let food sit in the oven for more than one hour before or after cooking. Doing so may result in food poisoning or illness.

Do not heat unopened containers (cans or jars) in the oven. Pressure may build up causing the container to explode, resulting in damage to the oven or personal injury.

Always place the oven racks at the desired height before cooking. If the racks must be moved when hot, use potholders to move them and use caution to avoid touching any heating elements.

Only certain types of glass, heatproof glass-ceramic, earthenware, or other glazed utensils are suitable for use on the surface burners. However, these types of materials may break with sudden temperature changes. Use only on low or medium heat settings, and according to their manufacturers' directions.

Bakeware, such as large casserole pans, cookie sheets, etc. should not be used on the surface burners. Large griddle plates that span across 2 burners should be used with care and on medium to low flame settings to avoid a build-up of heat which could distort the grates or the burner bowl.

Always position the handles of pot and pans so they do not extend over adjacent work areas or over the edge of the rangetop. This is to avoid knocking over hot contents which could burn you, or result in a fire.

Do not use pots or pans on the griddle (if equipped).

MODEL NUMBERS

RANGE MODELS

EN

MODEL NO.	DESCRIPTION	CIRCUIT BREAKER REQUIRED
KRG304-NG / -LP	30" GAS RANGE WITH 4 BURNERS	15 Amp
KRG365-NG / -LP	36" GAS RANGE WITH 5 BURNERS	15 Amp
KRG364GD-NG / -LP	36" GAS RANGE WITH 4 BURNERS & GRIDDLE	15 Amp
KRG485-NG / -LP	48" GAS RANGE WITH 5 BURNERS & 12" GRIDDLE	15 Amp
KRG484GD-NG / -LP	48" GAS RANGE WITH 4 BURNERS & 24" GRIDDLE	15 Amp



KRG304

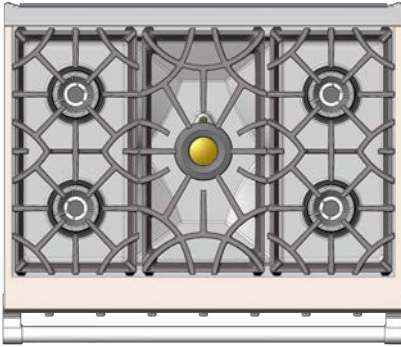

KRG365

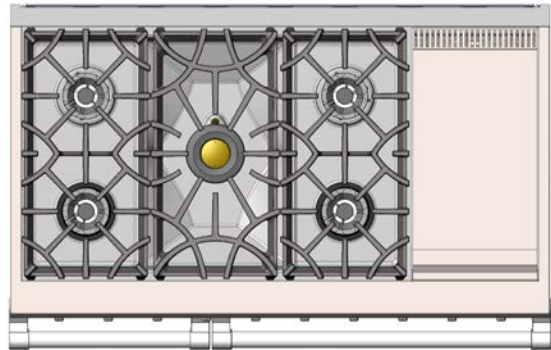

KRG485GD

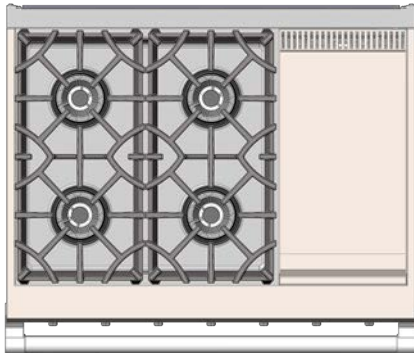

KRG364GD

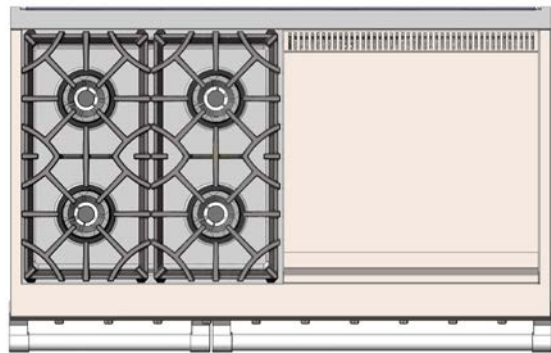

KRG484GD

RATING LABEL

The rating label contains important information about your Hestan appliance such as the model and serial number, gas type and manifold pressure, electrical rating, the BTU rating for each burner type, and the minimum installation clearances.

The rating label is located on the right side of the oven cavity opening near the door hinge.

If service is necessary, contact Hestan Customer Care with the model and serial number information shown on the label.

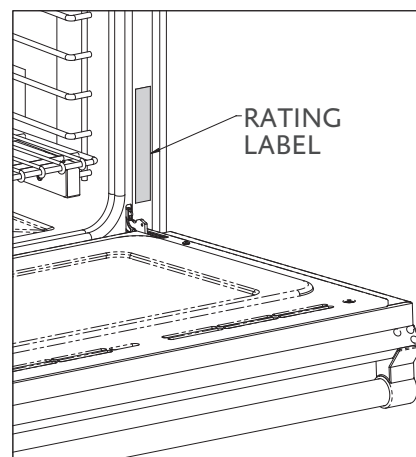

HESTAN COMMERCIAL CORP. ANAHEIM, CA - USA		MODEL / MODELE				SER. NO. / NO. SER.		PATENTED: http://www.hestanhome.com/patents.pdf	
GAS TYPE (TYPE DE GAZ)		BURNER RATINGS (BTU/HOURS)						MIN. CLEARANCES / DÉGAGEMENTS	
VOLTS 60		FRONT BURNER BRÛLEUR AVANT	REAR BURNER BRÛLEUR ARRIÈRE	GRIDDLE PLAQUE CHAUFFANTS	UPPER BURNER BRÛLEUR FOUR SUPÉRIEUR	LOWER BURNER BRÛLEUR FOUR INFÉRIEUR	BACK CLEARANCE	TO TOP OF CABINET	CONFORMS TO ANSI Z21.1-2016 / CSA 1.1-2016 HOUSEHOLD COOKING GAS APPLIANCE CONFORME À LA NORME ANSI Z21.1-2016 / CSA 1.1-2016 APPAREIL ÉLECTROMÉNAGER DE CUISISON AU GAZ VENTED UNIT - SEE INSTALLATION MANUAL UNITÉ VENTILÉE - VOIR LE MANUEL D'INSTALLATION
OUTLET PRESSURE (PRESSION SORTIE)						6"		0"	
PHASE 1						12"		0"	
INCH W.C. MPa									
AMPS									

REGULATORY / CODE REQUIREMENTS

Installation of this cooking appliance must be made in accordance with local codes. In the absence of local codes, this unit should be installed in accordance with the National Fuel Gas Code *ANSI Z223.1/NFPA 54*, Natural Gas and Propane Installation code *CSA B149.1*, or Propane Storage and Handling Code *B149.2*.

All Electrical Components must be electrically grounded in accordance with local codes or in the absence of local codes with the National Electrical Code *ANSI/NFPA 70*, or Canadian Electrical code *CSA C22.1*.

STATE OF MASSACHUSETTS

Massachusetts requires all gas be installed using a plumber or gas fitter carrying the appropriate Massachusetts license. All permanently installed natural gas or propane installations require a T-handle type manual gas valve be installed in the gas supply line to this appliance. Flexible gas connector must not be longer than 48" [1.2 m].

CALIFORNIA PROPOSITION 65 - WARNING



WARNING: This product can expose you to chemicals including carbon monoxide, which is known to the State of California to cause birth defects or other reproductive harm.
For more information, go to www.P65Warnings.ca.gov.

GETTING STARTED WITH YOUR APPLIANCE

COMPONENT IDENTIFICATION

Use the images below to familiarize yourself with the various parts of the rangetop and oven.

KRG30, KRG36

1. Island Trim Backguard (included)*
2. Sealed Burner
3. Burner Grate
4. Griddle (GD models)
5. Control Knobs
6. Oven
7. Oven Light Switch
8. Kick Plate

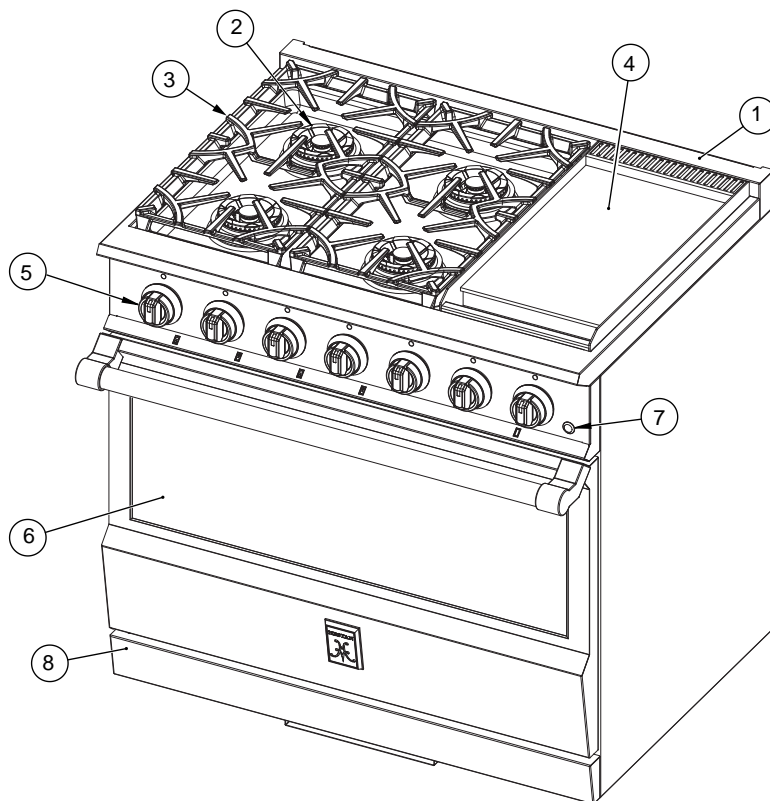

* Low or Tall Backguard ordered separately.

MODEL KRG364GD SHOWN

Oven cavity of 30" range, 36" range, main oven cavity of 48" range

1. Interior Light (2)
2. 6 Position Ladder Rack
3. Oven Rack (3 included)
4. Fan Cover
5. Broil Burner
6. Bake Burner (hidden)
7. Temperature Sensor

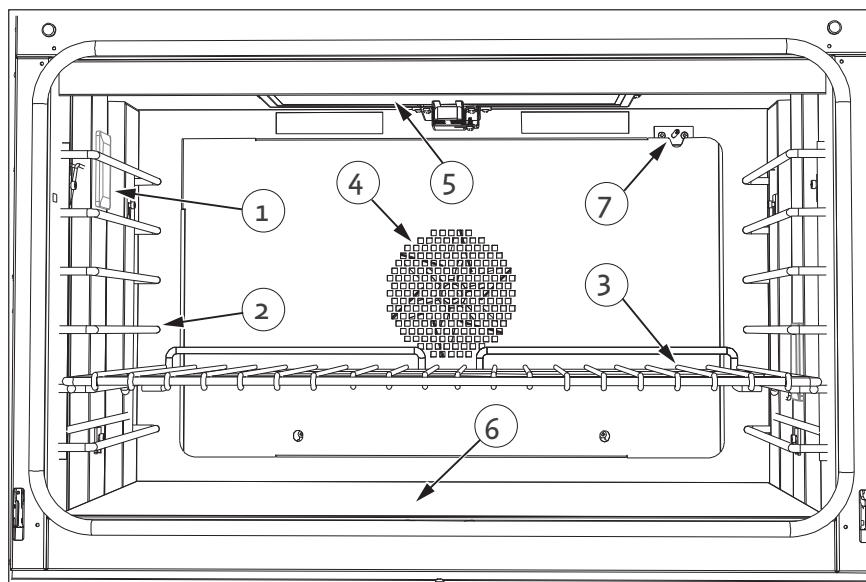

COMPONENT IDENTIFICATION (CONTINUED)

Use the images below to familiarize yourself with the various parts of the rangetop and oven.

KRG48

1. Island Trim Backguard (included)*
2. Griddle
3. Sealed Burner - Dual Flow
4. Sealed Burner - Single Flow
5. Burner Grate
6. Control Knobs
7. Oven Light Switch - Companion Oven
8. Oven Light Switch - Main Oven
9. Companion Oven
10. Main Oven
11. Kick Plate

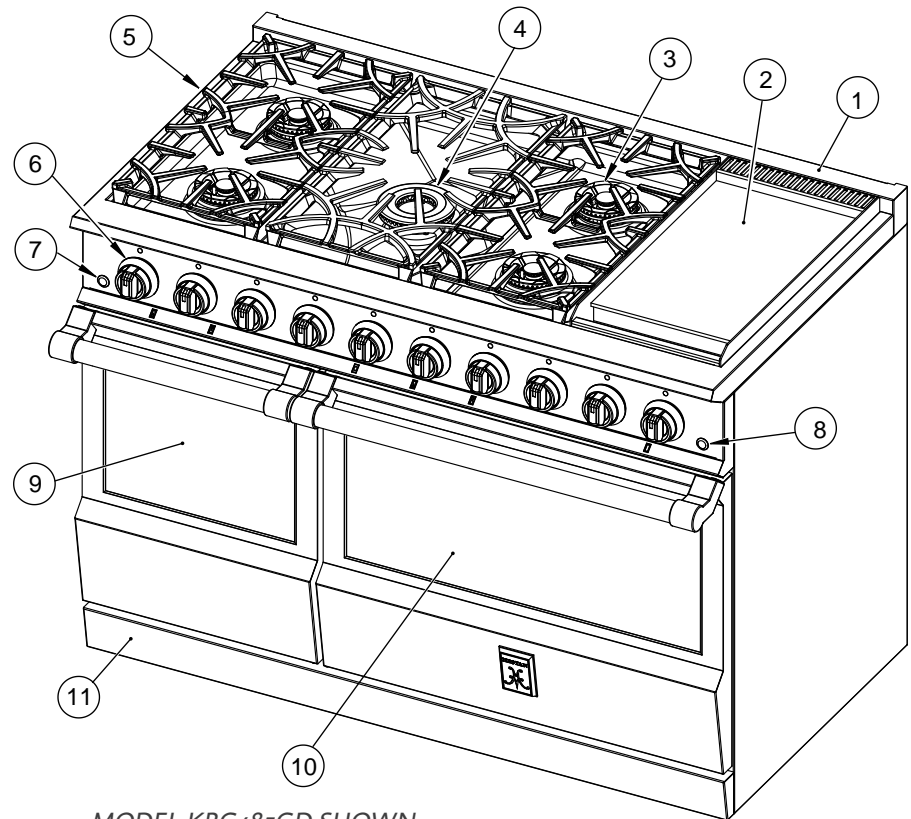

MODEL KRG485GD SHOWN

Companion Oven cavity of 48" range

1. 6 Position Ladder Rack
2. Oven Rack (3 included)
3. Fan Cover
4. Bake Burner (hidden)
5. Temperature Sensor
6. Interior Light

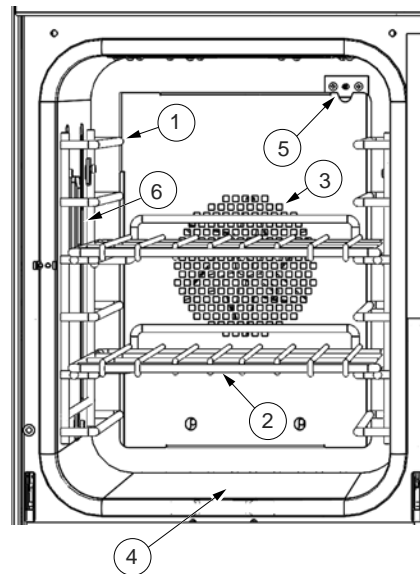

GETTING STARTED WITH YOUR APPLIANCE (CONTINUED)

EN

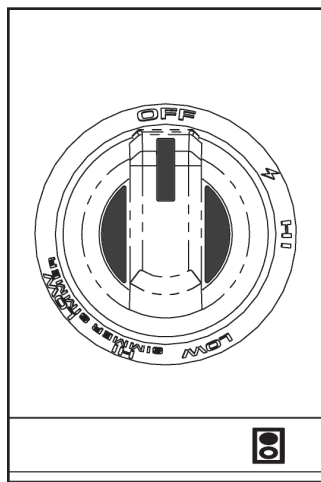

**DUAL-FLOW
BURNER**

ROTATE **LEFT** TO HI TO IGNITE BURNER. ADJUST FLAME AS NEEDED. THERE ARE 3 DETENT POSITIONS AT HI, LOW, AND HI SIMMER FOR EASE OF USE.

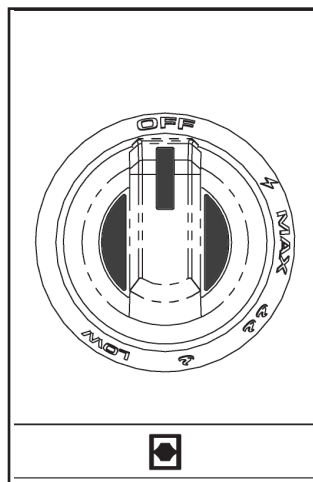

**SINGLE-FLOW
BURNER**

ROTATE **LEFT** TO MAX TO IGNITE BURNER. ADJUST FLAME AS NEEDED. THERE IS A DETENT AT THE MAX POSITION ONLY.

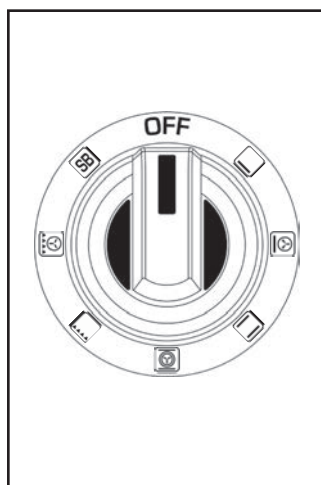

**OVEN MODE
SELECTOR**

ROTATE **LEFT** OR **RIGHT** TO SELECT OVEN MODE

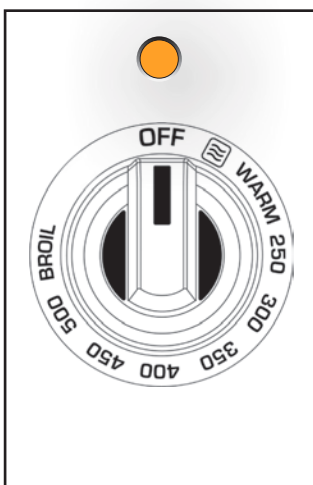

**OVEN
TEMPERATURE**

LED indicates one or both oven burners are active.

ROTATE **LEFT** OR **RIGHT** TO SELECT OVEN TEMPERATURE

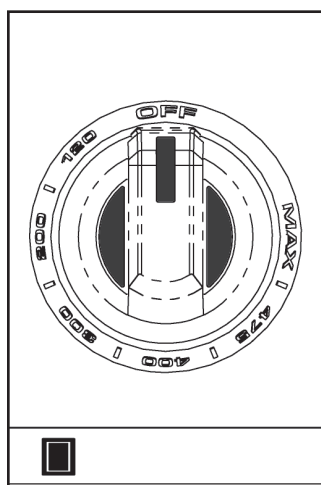

**GRIDDLE
TEMPERATURE**

ROTATE **RIGHT** TO SELECT GRIDDLE TEMPERATURE

GETTING STARTED WITH YOUR APPLIANCE *(CONTINUED)*

OVEN RACKS

▲WARNING

BURN HAZARD - To help prevent burns, never remove or reposition the oven racks when the oven is in operation, or is cooling.

▲WARNING

For safety considerations, NEVER cover any slots, holes, or passages in the oven bottom or cover an entire oven rack with materials such as aluminum foil. Doing so blocks air flow through the oven and may cause carbon monoxide poisoning. Aluminum foil linings may also trap heat, causing a fire hazard.

PLACING THE OVEN RACKS

The oven features ladder racks on the left and right side of the oven with 6 positions. Choose the rack position(s) that result in the best baking, roasting, etc. for your recipe. Rack position #3 (counting from the bottom-up) is the most popular position (vertical center location).

1. While raising the front of the rack slightly, place the rear lower hooks under the desired side ladder, then slide the rack back approximately 5" [13 cm].

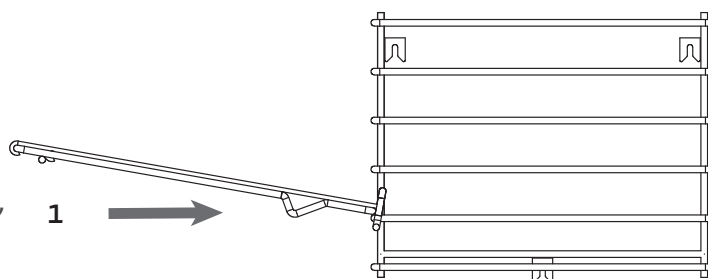

2. Lower the rack until it is level.

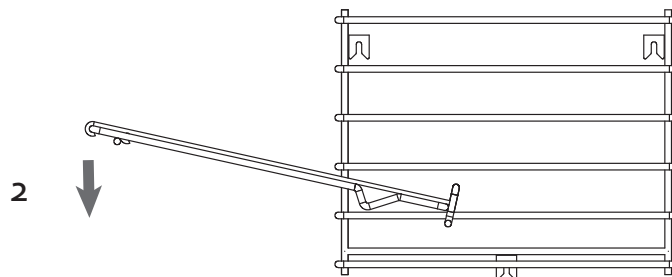

3. Continue sliding the rack back into the oven until it is fully inside.

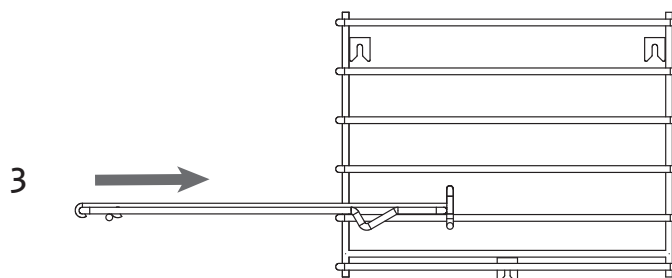

GETTING STARTED WITH YOUR APPLIANCE *(CONTINUED)*

SEALED BURNERS

Ensure the sealed burner heads are properly installed and seated on the burner base as shown below. There are notches on the burner base and cross ring to help with alignment. The outer burner head features a long slot on the top of the head which aligns with the spark igniter. Assembly of the single-flow burner head is similar.

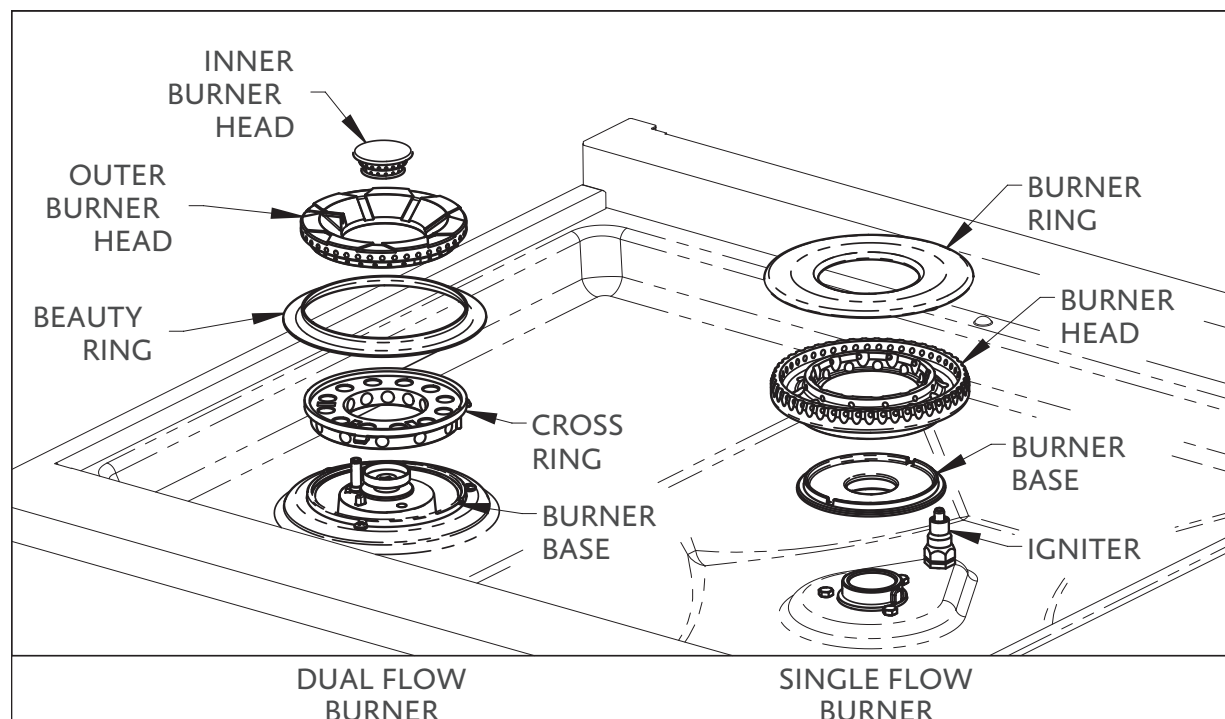

FIRST TIME OPERATION

Ensure there are no packaging materials inside the oven. Remove any labels or plastic film from the outside of the appliance. Before using your oven for the first time, it will be necessary to run a bake cycle to burn off any manufacturing oils and residues from the oven cavity. This may produce a little smoke and some odor. This is normal and is typical of any new oven when first used. If the smell is strong, remove persons and animals from the kitchen during this period. Open any windows to further vent the odor from the room.

Install all the oven racks. Turn on your vent hood, and run the oven on BAKE at 500°F [260°C] for 1-1/2 hours. Allow to cool completely before attempting to cook.

GETTING STARTED WITH YOUR APPLIANCE *(CONTINUED)*

EN

BURNER HEADS

If the burner head is not properly positioned, one or more of the following issues may occur:

- Flames too high
- Flames shoot out of the burners
- Burners do not ignite
- Flames are uneven
- Burner emits a gas odor

▲WARNING

BURN HAZARD - To prevent burns, do not touch the burner heads or cooking grates when hot. Allow to cool completely. To prevent flare-ups, do not use the burner without all the burner heads in place and properly positioned. Do not use aluminum foil to line the surface burners. Doing so may result in a risk of electric shock, or fire.

BURNER GRATES

See image for proper placement of the burner grates. There are small round embosses at the front and rear of the burner bowl to help align the grates and keep them in position relative to one-another.

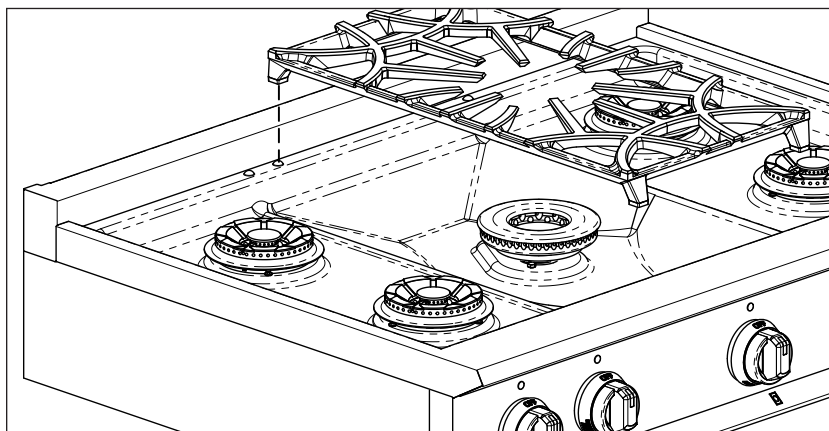

GRIDDLE PLATE (GD models)

See image for proper placement of the Griddle Plate and Grease Tray.

▲CAUTION

Be sure to remove the cover before turning the griddle on.

The plate is made of stainless-steel and requires no seasoning. The grease tray has a non-stick coating for easy cleaning.

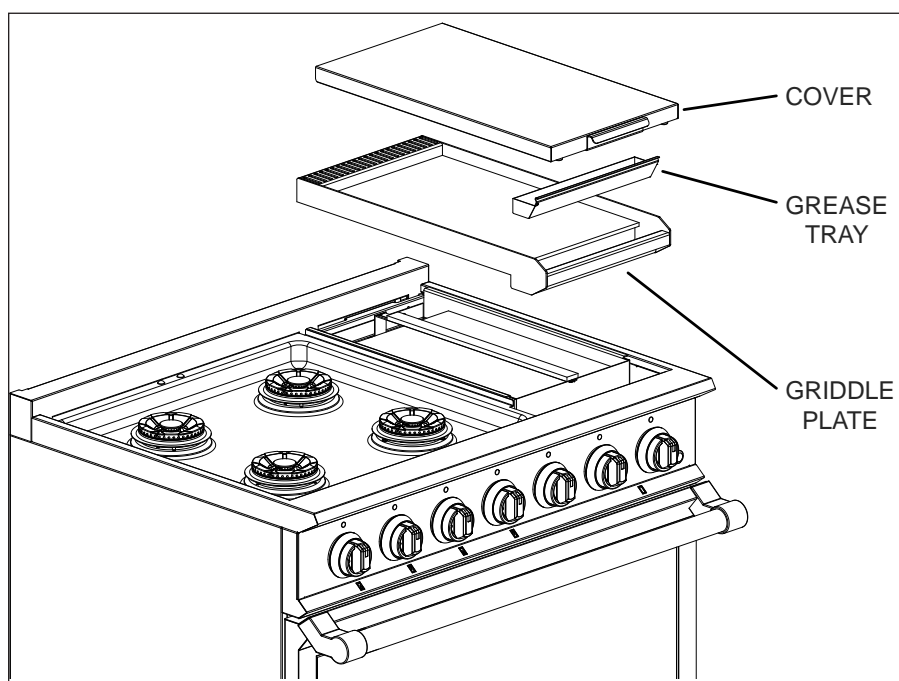

USING THE RANGETOP

BURNER CONTROL KNOBS

Each sealed burner has its own control knob. The symbol below each knob indicates which burner is controlled by each knob. Push and turn LEFT (counter-clockwise) to HI to ignite the flame, then turn to the desired flame setting.

BURNER TYPES & OUTPUT

This table below indicates the type and output of each sealed burner. Dual-flow burners have an inner and outer row of ports, with a simmer function. The single-flow burner (some models) is similar to a commercial burner and features very high output, and a low, but no simmer function.

BURNER OUTPUT - NATURAL GAS

DUAL-FLOW (FRONT)	OUTPUT (BTU/hr)	DUAL-FLOW (REAR)	OUTPUT (BTU/hr)	SINGLE FLOW	OUTPUT (BTU/hr)
HI	23000	HI	15500	MAX	30000
LOW	4200	LOW	4200	LOW	4200
SIMMER HI	1500	SIMMER HI	1500		
SIMMER LOW	500	SIMMER LOW	500		

BURNER OUTPUT - PROPANE

DUAL-FLOW (FRONT)	OUTPUT (BTU/hr)	DUAL-FLOW (REAR)	OUTPUT (BTU/hr)	SINGLE FLOW	OUTPUT (BTU/hr)
HI	23000	HI	15500	MAX	22000
LOW	4200	LOW	4200	LOW	4200
SIMMER HI	1500	SIMMER HI	1500		
SIMMER LOW	600	SIMMER LOW	600		

RE-IGNITION

Each sealed burner has its own electronic spark-ignition module with flame-sensing technology and automatic re-ignition capability. If any burner should blow out, the igniter automatically re-lights the burner.

Each burner should light in less than 4 seconds. Once lit, the sparking will stop. On very low simmer, an occasional sparking may occur. This is usually due to a breeze in the room. If an igniter continues to spark even with a flame present, there could be an electrical wiring issue, or some other problem. See the TROUBLESHOOTING section of this manual for more information.

WARNING

DO NOT touch the burner or the igniters while sparking is occurring. A shock hazard or burns could occur.

MANUAL LIGHTING / POWER FAILURE

THE OVEN AND GRIDDLE CANNOT BE USED DURING A POWER FAILURE.

Each sealed burner can be manually lit in the event of a power failure. It is necessary to light each burner individually.

If a power failure occurs WHILE you are using the sealed burners, turn all the knobs to the OFF position - then light manually with a match or fireplace lighter.

Position the match or fireplace lighter at the port nearest the igniter, then turn the knob to HI until the flame is lit. Wait until the flame has lit all the way around the burner before adjusting the knob to LOW or SIMMER.

IF YOU SMELL GAS, turn all control knobs to OFF - check the precautions listed in the SAFETY section of this manual.

USING THE RANGETOP (CONTINUED)

FLAME HEIGHT

Proper flame height depends on the size of the pan being used, and the amount of food or liquid in the pan. In other words, don't use a small pan over a large flame. For safety reasons, control the flame height so that it doesn't go beyond, or curl up the sides of your pot or pan. This behavior results in poor heating of the contents of the pan, burnt food on the sides of the pan, wasted fuel, etc.

Use a low or medium flame on items that heat slowly, such as glass-ceramic pots.

FLAME CHARACTERISTICS

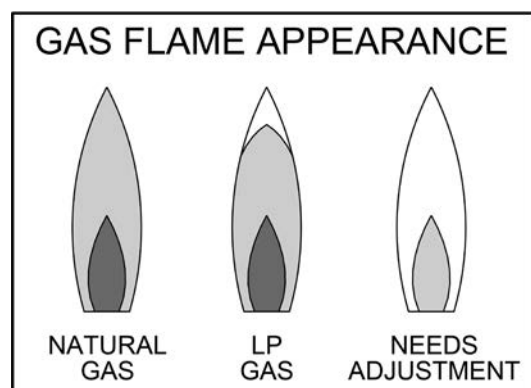

Light blue flame - Natural gas normal flame

Light blue flame with yellow tips - LP gas normal flame

Yellow flame - Needs adjustment

If the flame is mostly or completely yellow, check the position of the burner heads again for proper installation, and/or review the FINAL SETUP section of the installation manual for more details.

HOW TO USE YOUR RANGETOP

DUAL FLOW BURNERS

The benefit of the dual-flow burner is the amount of control and precision the burners give you, allowing for the best results possible.

Simmer-Low is ideal for heating delicate foods without having the fear of burning, scalding, or boiling over. Some suggestions include:

- Melting chocolate
- Heating milk or cream
- Melting sugar
- Slow cooking or braising

SINGLE FLOW BURNER (some models)

Ideal Uses:

- Searing
- Boiling water
- Large stock pots – will allow for even heat distribution under larger surface areas
- Wok Cooking: We suggest a 14-16 inch [36-41 cm] wok for the best results.

COOKWARE RECOMMENDATIONS

As previously stated in "PROPER USAGE" on page 7, bakeware such as large casserole pans, cookie sheets, etc. should not be used on the surface burners. Large griddle plates that span across 2 burners should be used with care and on medium to low flame settings to avoid a build-up of heat which could distort the grates or the burner bowl.

Large stock pots should be staggered when used on the rangetop (see below).

Do not cook on aluminum foil or thin, disposable aluminum pans. These can melt.

Never let a pot boil dry. If left too long, the pan could melt, or damage the appliance.

Use only high-quality pans with metal handles. Some plastic handles could melt from the intense heat of the burners.

USING THE RANGETOP *(CONTINUED)*

EN

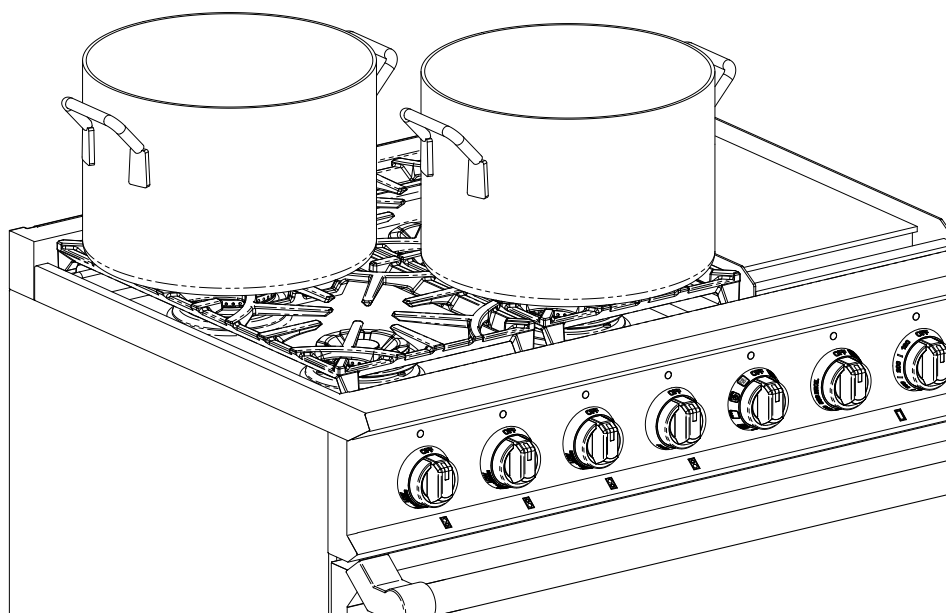

USING THE GRIDDLE *(SOME MODELS)*

GRIDDLE CONTROL KNOB

The griddle is electronically controlled with a temperature range of 120°F - MAX (approx. 500°F) [49 - 260°C]. Push and turn RIGHT (clockwise) to select the desired temperature for the food you are cooking.

▲WARNING

To avoid injury DO NOT operate the griddle without the griddle plate and grease tray in place. Remove the cover before use.

▲CAUTION

The griddle is very hot after use. Allow sufficient time to cool down before cleaning.

DO NOT use metal utensils (pots, pans, etc.) on the griddle plate surface. Be careful not to gouge or cause deep scratches in the griddle plate surface. DO NOT cut directly on the griddle plate.

FIRST TIME OPERATION

Before using your griddle for the first time, the griddle plate and the grease tray should be cleaned with warm, soapy water and thoroughly rinsed and dried. When you first heat the plate, a little smoke and some odor may be present as any remaining manufacturing oils are burned off. The stainless-steel plate will discolor from a straw color, to a very dark brown or black, depending on what foods you cook on the surface.

USING THE GRIDDLE *(CONTINUED)*

COOKING ON THE GRIDDLE

When it comes to using the griddle, there are a few things to keep in mind:

- As time goes on and griddle use increases, discoloration of the griddle plate may happen and is normal.
- When emptying the grease tray, be sure to pour the grease into a proper container for grease disposal, not down the drain. Do not scrape with metal utensils.

It will take some practice to get to know how your griddle performs with certain foods. The table below gives a few recommendations on temperatures.

FOOD ITEM	GRIDDLE TEMPERATURE
EGGS	300 - 325°F [149 - 163°C]
PANCAKES, FRENCH TOAST	400 - 425°F [204 - 218°C]
HASH BROWN POTATOES (frozen)	475 - 500°F [246 - 260°C]
CHICKEN BREAST, (BONELESS)	425 - 450°F [218 - 232°C]
BACON, SAUSAGE	450 - 475°F [232 - 246°C]
STEAK, 1" (25mm) THICK	450 - 475°F [232 - 246°C]
HAMBURGER, 6 oz (170 g)	450 - 475°F [232 - 246°C]

CLEANING THE GRIDDLE

Read the CLEANING AND MAINTENANCE section of this manual for complete instructions.

NEVER flood the hot griddle plate with cold water. This can permanently warp the plate.

Do not put your griddle plate into the dishwasher, as it will damage your appliance.

Wait until the appliance has cooled completely before cleaning.

USING THE OVEN

TIPS AND TRICKS ON HOW TO USE YOUR OVEN

As you begin to use your Hestan Range, it is important to take the time to become familiar with the new settings and the performance of this appliance. Previous ranges may have performed differently than your Hestan – allow some time to adjust.

HOW TO GET THE BEST RESULTS WHEN COOKING IN THE OVEN

- Many recipes give their own rack suggestions, it is best to follow what is suggested by the recipe.
- After a few times of using your new range, you will become more comfortable with rack placements and temperature settings.
- Avoid opening the oven door while cooking. This will prevent heat from escaping and provide the best results.
- Make sure to preheat the oven to the cooking temperature given in the recipe.
- When baking with more than one rack, stagger the pans and give them at least 2" of space between each pan.
- Remember that different bakeware and pans cook and heat differently.
- Light-colored non-stick pans result in golden crust that is tender.
- Dark-colored non-stick pans result in a more brown, crisp crust.
- Generally, when using any Convection mode, it is suggested to reduce the temperature by 25°F [14°C], though this does not apply to all recipes or meats and poultry.

USING THE OVEN (CONTINUED)

RACK POSITION / BEFORE BAKING

Rack positions depend on the food items you are baking or roasting. Follow the instructions, or your best experience, on which rack position is best to use for a given recipe.

Not all oven racks need to be kept in the oven. If you find you only need one or two racks most of the time, remove the extra rack and store in a convenient location should it be needed later.

ALWAYS place the oven racks at the desired height before cooking. If the racks must be moved when hot, use potholders to move them and use caution to avoid touching any hot oven parts.

Minimize opening the oven door by using the oven light.

QUICK GUIDE FOR RACK POSITIONS / USES

Choose the rack position(s) that result in the best baking, roasting, etc. for your recipe. Rack position #3 (counting from the bottom-up) is the most popular position (vertical center location).

OVEN MODE	SUGGESTED RACK POSITIONS	USES
PROOF	N/A	Best for allowing bread dough to rise.
BAKE	Center rack #3	Best for baked items. Single-rack cooking or baking. This is the standard mode for most recipes.
CONVECTION BAKE	Single Rack: #3 Two Racks: #3 & #5	During this mode, a fan in the back of the oven helps air move evenly throughout, allowing for even baking and cooking.
ROAST	Center rack #3	Roast less tender cuts of meat such as beef roast. Also good for stews that have to be covered.
CONVECTION ROAST	Center rack #3	This mode allows for a crisp outside and a tender and juicy interior on poultry and meats. Ideal for roasting tender cuts of beef lamb poultry.
BROIL	Rack #5 for steaks, hamburgers, etc. 1" [2.5cm] and under. Rack #4 for steaks, hamburgers, etc. thicker than 1" [2.5cm].	Broiling meats, fish, and poultry pieces. Direct heat from above only. Pre-heat broil for 3-4 minutes before starting cooking.
CONVECTION BROIL	Rack #5 for steaks, hamburgers, etc. 1" [2.5cm] and under. Rack #4 for steaks, hamburgers, etc. thicker than 1" [2.5cm].	Shortens broiling times for thicker cut of meat, fish, poultry. Pre-heat broil for 3-4 minutes before starting cooking.

PRE-HEATING

Many recipes call for a pre-heated oven. Refer to your recipe for instructions. Pre-heating time depends on the Mode and Temperature selected, as well as the number of racks inside the oven.

- The indicator LED is ON when either the broiler or main burner is active.
- The LED will be ON while the oven is heating
- The LED will go OFF when the oven is up to temperature.

During cooking, the burner(s) will cycle on and off to maintain the set temperature, and the LED will indicate burner activity.

USING THE OVEN (CONTINUED)

APPROPRIATE BAKeware / PLACEMENT

Bakeware suitable for use in your Hestan oven are metal, heat-proof glass (Pyrex®), glass-ceramic, earthenware pottery, etc. Cookie sheets / jelly roll pans with a small lip are also suitable. Thicker sheets or double-sided sheets may increase baking times.

Stagger multiple cake pans as shown here. Leave approximately 2" [5 cm] space between all pans and oven walls to allow for hot air circulation inside the oven.

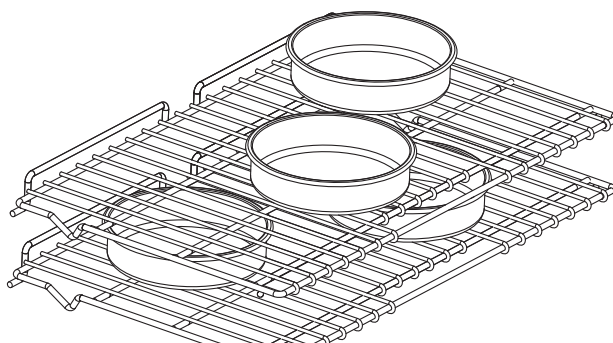

EN

COOKING WITH THE OVEN

The following pages will help you with the various oven controls. Your recipe will guide you on which cooking modes are best. However, food safety (handling, cooking, storage) is very important in preventing food-borne illness. The table below are recommendations to keep you and your family safe.

FOOD ITEM	SAFE MINIMUM INTERNAL TEMPERATURES
GROUND MEATS (BEEF, VEAL, LAMB, PORK)	160°F [72°C]
BEEF, VEAL, LAMB ROAST, STEAKS, CHOPS	Medium Rare - 145°F [63°C]
	Medium - 160°F [72°C]
	Well Done - 170°F [77°C]
PORK ROAST, STEAKS, CHOPS	Medium - 160°F [72°C]
	Well Done - 170°F [77°C]
HAM	Un-cooked - 145°F [63°C]
	Reheat cooked hams packaged in USDA-inspected plants to 140 °F [60°C] and all others to 165 °F [74°C]
GROUND CHICKEN/TURKEY	165°F [74°C]
WHOLE CHICKEN/TURKEY	180°F [82°C]
POULTRY BREAST, ROASTS	165°F [74°C]
POULTRY THIGHS & WINGS	165°F [74°C]
STUFFING (cooked alone)	165°F [74°C]
EGG DISHES	160°F [72°C]
FISH & SHELLFISH	145°F [63°C]
LEFTOVERS	165°F [74°C]
CASSEROLES	165°F [74°C]

- Safe minimum internal temperatures per US Dept. of Agriculture Food Safety & Inspection Services guidelines.

OVEN CONTROLS

OVEN KNOBS AND ICONS

KRG36, KRG30, Main Oven of KRG48

EN

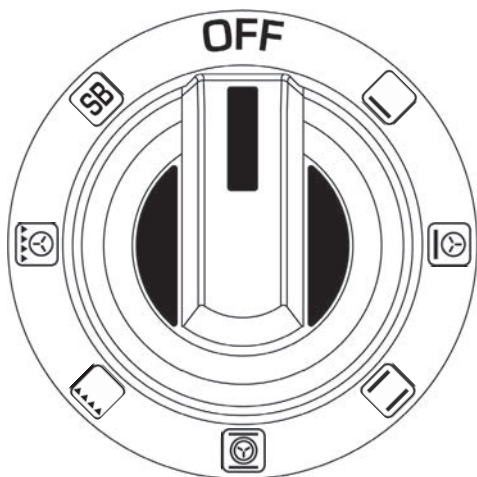

OVEN MODE SELECT

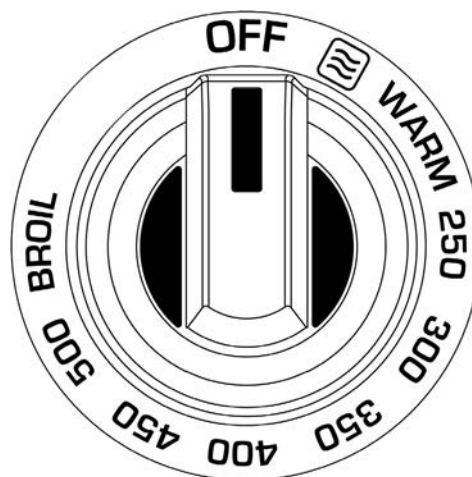

OVEN TEMPERATURE

Oven Function Icons



Bake



Convection
Bake



Broil



Roast



Convection
Broil



Convection
Roast



Sabbath
Mode

OVEN CONTROLS (CONTINUED)

OVEN KNOBS AND ICONS - COMPANION OVEN

KRG48 only

EN

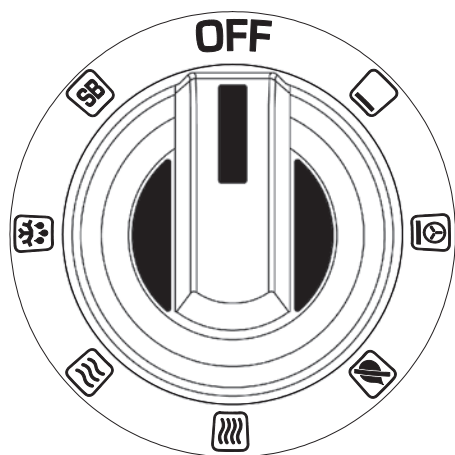

COMPANION OVEN MODE SELECT

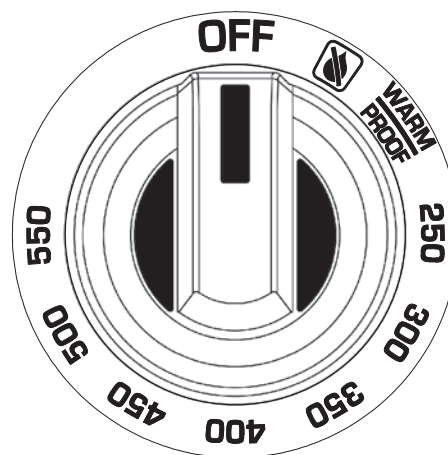

COMPANION OVEN TEMPERATURE

Function Icons - Companion Oven



Bake



Convection
Bake



Proofing



Dehydrate



Defrost



Warming



Sabbath
Mode

OVEN CONTROLS (CONTINUED)

BASIC OVEN USE

For most use, simply set the Mode Select knob and then set the temperature.

The indicator LED will come on, then go off when the oven reaches set temperature. See "PRE-HEATING" on page 20.

In the example at the right, the Mode Select knob has been turned to the Convection Broil function. The Oven Temperature knob has been set to 350°F

When finished cooking, turn both knobs to OFF.

NOTES:

- In the event of a power failure, the oven turns off. Once power is restored, the oven will remain off. To resume cooking, turn both knobs off, then set desired mode and temperature.
- See "IN CASE OF POWER OUTAGE" on page 5 for instructions.

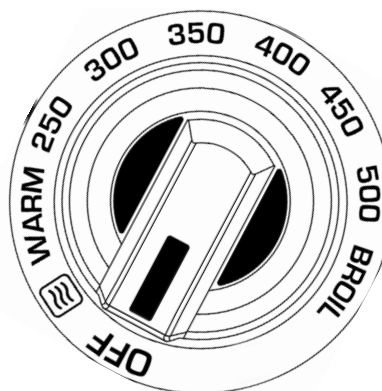
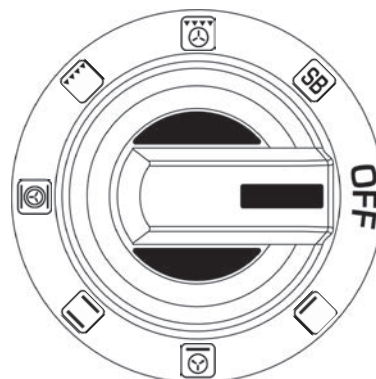

SETTING SABBATH MODE

- Turn the Function knob to SB (Sabbath). For 48" models, turn Function knobs for both ovens to SB. (if both ovens will be used)
- Turn the Temperature knob to the desired setting. For 48" models, set each oven's temperature knob as preferred.



The Sabbath Mode operates the oven in bake mode. The oven internal lights and the oven knob backlights do not operate in Sabbath mode.

CANCELING SABBATH MODE

To cancel Sabbath mode, turn the Mode Select knob Off. For 48" models, turn both Mode Select knobs OFF.

NOTES:

- During Sabbath Mode, changes made to the oven temperature knob result in a computed random delay of up to 3 minutes before engaging the oven burner.
- The Rangetop burner(s) will auto-ignite if the flame is somehow snuffed out.
- Rangetop burner(s) do not have a programmed time-out and are able to remain lit indefinitely or during the entire Sabbath. A low flame setting is recommended.
- In the event of a power failure during Sabbath Mode, the oven turns off. Once power is restored, the oven will remain off.
- See "IN CASE OF POWER OUTAGE" on page 5 for instructions.

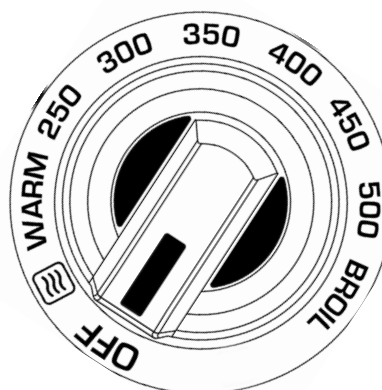
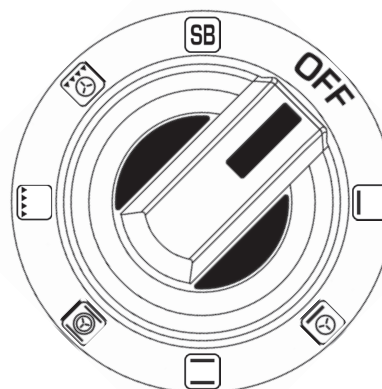

OVEN CONTROLS (CONTINUED)

BAKE COOKING MODE

1. Turn the Mode Select knob to the BAKE setting.
2. Set the Temperature knob to the desired cooking temperature. In this example, it has been set to 250°F.

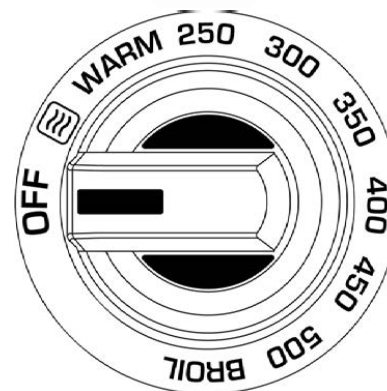
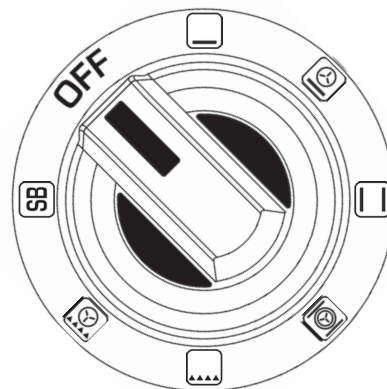

CONVECTION BAKE COOKING MODE

1. Turn the Mode Select knob to the CONVECTION BAKE setting.
2. Set the Temperature knob to the desired cooking temperature. In this example, it has been set to 250°F.

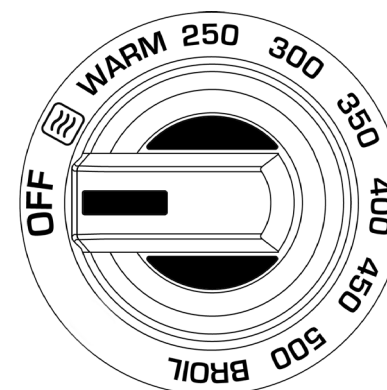
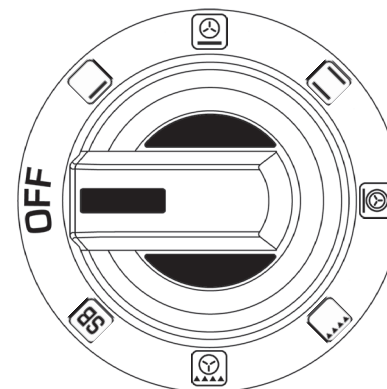

TIPS:

- This mode is best used for baked goods.
- Using pans with low sides helps to get the most even flow of heated air to the food.
- No need to rotate the pan when using this mode.

NOTES:

- a. In general, convection cooking should be done using low, shallow bakeware or pans to allow the heated air to circulate around the food.
- b. Removal of any lids is also recommended for the same reason.

OVEN CONTROLS (CONTINUED)

ROAST COOKING MODE

1. Turn the Mode Select knob to the ROAST setting.
2. Set the Temperature knob to the desired cooking temperature. In this example, it has been set to 375°F.

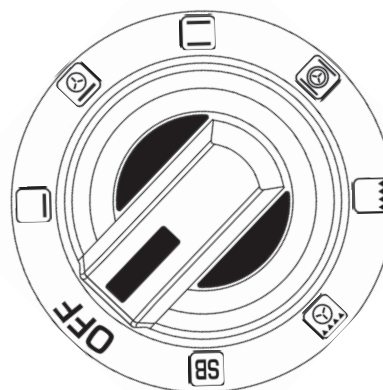

TIPS:

- Designed for less tender cuts of meat.
- It helps to add moisture such as broths and liquids when cooking meats on this mode.

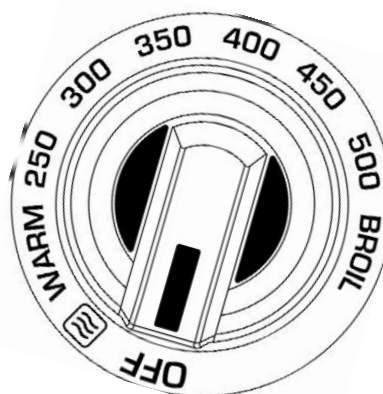

CONVECTION ROAST COOKING MODE

1. Turn the Mode Select knob to the CONVECTION ROAST setting.
2. Set the Temperature knob to the desired cooking temperature. In this example, it has been set to 375°F.

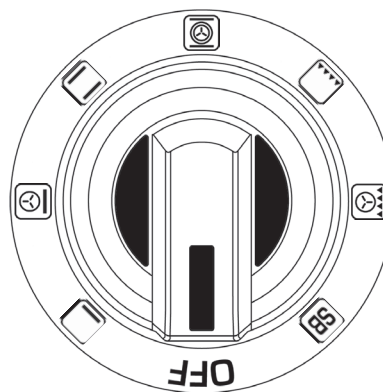

TIPS:

- Best for roasting.
- Provides a crispier skin while maintaining a juicy interior in poultry and meats.
- No need to drop temperature by 25°F [14°C].
- Check internal temperature when cooking poultry and meats.

NOTES:

- a. In general, convection cooking should be done using low, shallow bakeware or pans to allow the heated air to circulate around the food.
- b. Removal of any lids is also recommended for the same reason.

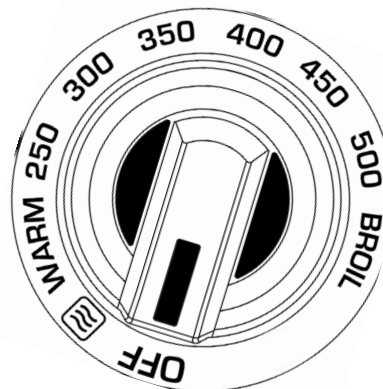

OVEN CONTROLS (CONTINUED)

BROIL COOKING MODE *

1. Turn the Mode Select knob to the BROIL setting.
2. Set the Temperature knob to the BROIL setting.

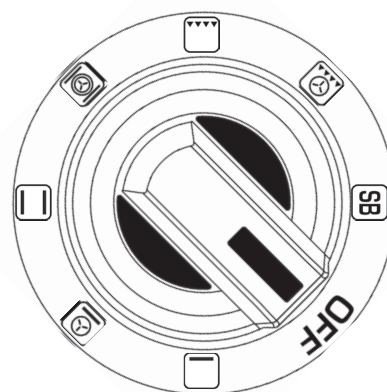

TIPS:

- This mode is excellent for broiling steaks, ground beef patties, and browning the top of foods.
- The door should remain closed during the entire broiling period.
- Make sure the pan is placed in the center of the rack, directly under the broil element.
- Food only needs to be turned once. Thin foods such as fish do not need to be flipped.
- Use the provided broiler pan and slotted cover when broiling, making sure to leave the slots of the cover open. Do not line with foil.
- Be careful when opening the oven door during broil as intense heat has been accumulating for a period of time.

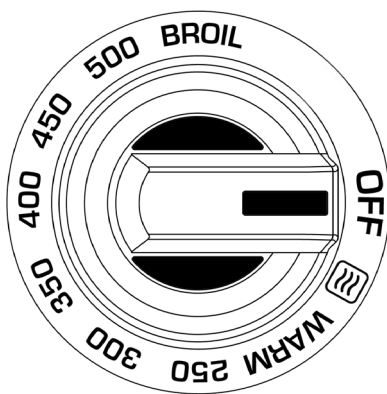

CONVECTION BROIL COOKING MODE *

1. Turn the Mode Select knob to the CONVECTION BROIL setting.
2. Set the Temperature knob to the BROIL setting.

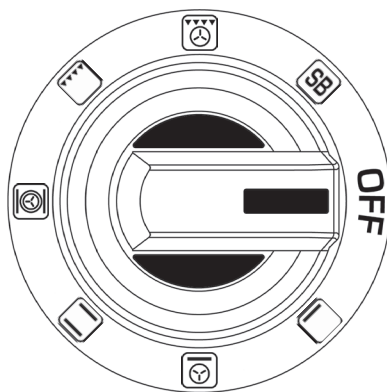

TIPS:

- Similar tips as BROIL.
- Please refer to recipe instructions for best results.

NOTES:

- a. In general, convection cooking should be done using low, shallow bakeware or pans to allow the heated air to circulate around the food.
- b. Removal of any lids is also recommended for the same reason.

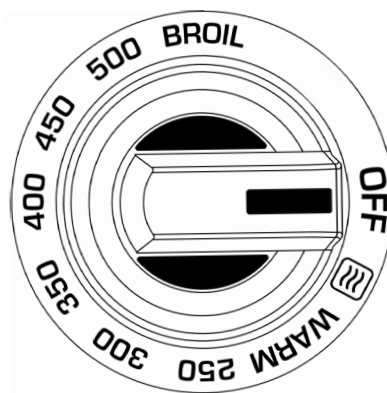

* Broil, Convection Broil modes not available in companion oven of 48" range.

OVEN CONTROLS (CONTINUED)

PROOF COOKING MODE

1. Turn the Mode Select knob to the BAKE setting.
2. Set the Temperature knob to the PROOF setting.

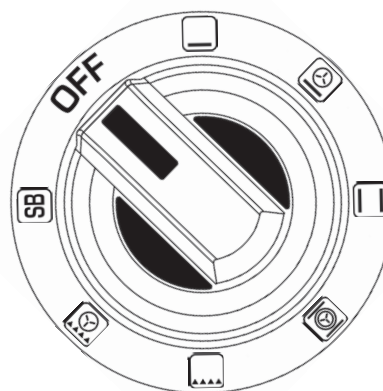

NOTES:

- a. The PROOF setting is a very low oven temperature around 100°F [38°C] for assisting yeast-leavened breads and other baked goods to rise.
- b. It is best to start with a cool oven when using this setting.

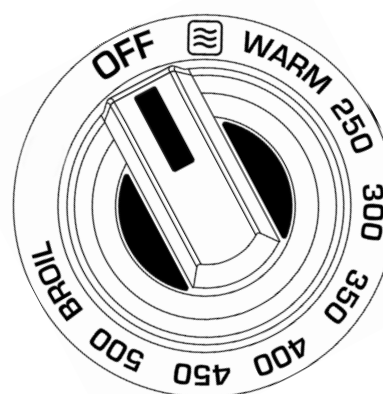

ADDITIONAL ITEMS

COOLING BLOWER

The range features a cooling blower to protect the electronic components. The blower activates when the oven reaches a temperature around 300°F [149°C], and will stay on throughout any oven cooking cycle. After cooking, even though you may have shut off the oven, the blower will remain on until the oven cools down to a temperature near 250°F [121°C].

If you notice the blower fails to activate during any oven cycle (especially Broil), do not use the oven. Call for service. Failure to do so may permanently damage the oven.

BROILER PAN

The range is supplied with a porcelain enamel 2-piece broiler pan with slotted cover. The slotted cover allows drippings to flow into the base of the pan, away from the intense heat of the broiler. This will reduce smoke and the chance of a grease fire.

DO NOT use aluminum foil or thin, disposable aluminum pans when broiling. These can melt.

CARE & MAINTENANCE

CLEANING OVEN



EN

BURN HAZARD - All parts of the range can get very hot during operation. The oven door glass and areas surrounding the door get very hot. Do not touch the appliance while in operation. Failure to observe these instructions may result in severe burns or injury. Do not allow children to use this appliance without adult supervision. Do not allow children to play in or around the appliance, even when not in use.

OVEN INTERIOR

Try wiping up the spill with warm soapy water, or a mild cleanser such as Fantastik® or SoftScrub®. Rinse and dry thoroughly. If you choose to use a commercial oven cleaner, follow the instructions on the product label.

OVEN EXTERIOR / GLASS

Do not allow food stains or salt to remain in contact with stainless steel surfaces too long. The stainless steel exterior of the oven may be cleaned with warm soapy water, or any number of commercial stainless steel cleaners. Check to make sure the cleaners do not contain chlorine or chlorine compounds as these are corrosive to stainless steel. Rinse thoroughly.

SUGGESTED CLEANERS:

Hot water & mild detergent

Fantastik®

These cleaners may also be effective in areas with heat discoloration. ALWAYS clean stainless steel in the direction of the grain with light pressure.

If your Hestan appliance has colored panels, use warm soapy water ONLY. Rinse and dry thoroughly.

Be careful when cleaning near the oven door vents at the top of the oven glass. Water or cleaners could get inside and leave spots or streaks on the inside of the glass.

Do not rub, disturb or damage the cloth-braided door gasket. If the gasket is damaged, it will need to be replaced. Use only Hestan genuine replacement parts.

Wait until the appliance is completely cool before using any aerosol-type cleaners. Many of these cleaners use flammable propellants which could ignite in the presence of heat.

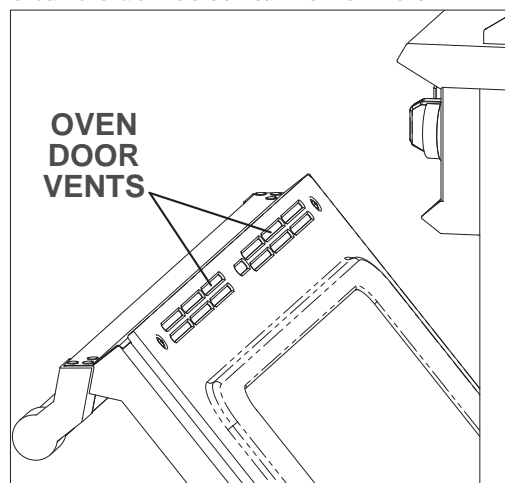

CARE & MAINTENANCE (CONTINUED)

LADDER RACKS / OVEN RACKS

The oven racks and the left & right ladder racks can be removed from the oven for cleaning.

The racks may be cleaned with warm soapy water, or any number of commercial stainless steel cleaners. Check to make sure the cleaners do not contain chlorine or chlorine compounds as these are corrosive to stainless steel. Rinse thoroughly. If the racks do not slide easily after cleaning, apply a small amount of food-safe or cooking oil to the slide rails.

SUGGESTED CLEANERS:

Hot water & mild detergent

Vinegar & water

Fantastik®

Bon-Ami®

Kleen King®

SoftScrub®

SEALED BURNERS

▲WARNING

BURN HAZARD - To prevent burns, do not touch the burner heads or cooking grates when hot. Allow to cool completely.

The burners can be disassembled for cleaning. Use only a small toothbrush to clean the burner ports and igniter. DO NOT insert sharp objects or scratch the burner ports. After cleaning, ensure the sealed burner heads are properly installed and seated on the burner base as shown below. There are notches on the burner base and cross ring to help with alignment. The outer burner head features a long slot on the top of the head which aligns with the spark igniter. Assembly of the single-flow burner head is similar.

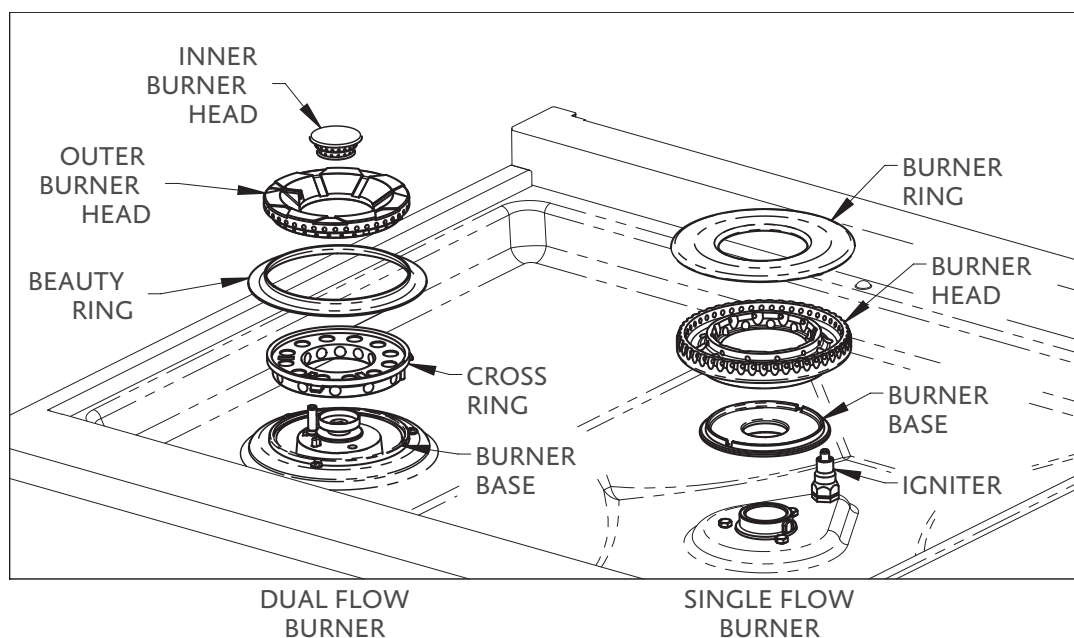

CARE & MAINTENANCE (CONTINUED)

EN

SUGGESTED CLEANERS:

BRASS BURNER / HEADS

Hot water & mild detergent

Bon-Ami®

Kleen King®

CERAMIC IGNITER

Hot water & mild detergent

Fantastik®

CAST IRON COOKING GRATES WITH PORCELAIN ENAMEL

Hot water & mild detergent

Bon-Ami®

Kleen King®

SoftScrub®

Use care when handling the grates. They are heavy and can crack if dropped on the floor or hard surface. DO NOT clean the grates in a self-cleaning oven. Do not allow food stains or acidic food spills to remain on the grate surfaces too long. These stains can degrade the enamel. For stubborn stains, use light pressure with an abrasive cleaner. Rinse thoroughly and dry immediately.

GRIDDLE PLATE & GREASE TRAY (if equipped)

WARNING

BURN HAZARD - To prevent burns, do not touch the griddle plate or grease tray when hot. Allow to cool completely.

NEVER flood a hot griddle plate with cold water. The steam could cause serious burns. The sudden temperature change could also distort the metal surfaces resulting in permanent warpage of the plate. DO NOT clean the griddle plate in a self-cleaning oven.

The griddle plate can be removed for cleaning by hand using warm soapy water. For more difficult residues, you can rub coarse salt on the plate, and rinse thoroughly with clean water. The grease tray has a non-stick coating which may be cleaned by hand using warm soapy water, or it may be cleaned in the dishwasher. Do not use sharp objects or scrapers, as this may gouge the surfaces.

EXTERIOR SURFACES

Do not allow food stains or salt to remain in contact with stainless steel surfaces too long. All stainless steel exterior surfaces may be cleaned with warm soapy water, or any number of commercial stainless steel cleaners. Check to make sure the cleaners do not contain chlorine or chlorine compounds as these are corrosive to stainless steel. Rinse thoroughly.

SUGGESTED CLEANERS:

Hot water & mild detergent

Fantastik®

ALWAYS clean stainless steel in the direction of the grain with light pressure.

If your Hestan appliance has colored panels, use warm soapy water ONLY. Rinse and dry thoroughly.

Wait until the appliance is completely cool before using any aerosol-type cleaners. Many of these cleaners use flammable propellants which could ignite in the presence of heat.

CARE & MAINTENANCE (CONTINUED)

REPLACING THE OVEN LIGHT BULB

⚠️ WARNING

ELECTRICAL SHOCK HAZARD - Make sure the power has been shut off to the range. The light socket is energized when the door is open. Failure to shut off the power when replacing a light bulb could result in electric shock or burns.

Make sure the glass lens is cool to the touch. Use care when handling the lens, it is fragile and can break if dropped.

Use only 20 watt, 12 Volt, halogen "Bi-Pin" bulbs suitable for appliance oven use. This type of bulb may be available at hardware stores & home centers, or specialty lighting stores. Call Hestan Customer Care for more information.

1. MAKE SURE POWER IS OFF! Open the oven and remove the oven racks and ladder racks if they are in the way.
2. Place a thick towel or cloth on the oven floor below the lamp to catch the glass lens should it fall.
3. Use a small flat-blade screwdriver to carefully pry off the glass lens and set aside. Reach into the lamp housing and pull out the old light bulb as shown in the image below.
4. Before installation, it is very important to clean the new bulb carefully with a clean, soft cloth, or tissue paper. Grease, fingerprints, or oils in your skin can leave a residue on the glass surface of the bulb which will create a hot-spot. The bulb will eventually crack at this hot-spot.
5. While still using a cloth or tissue paper, insert the new bulb in the lamp housing. Push the bulb fully into the socket.
6. Re-install the glass lens taking note of the cutaway in the glass which aligns with the bulb socket.
7. Restore the power and check if the new bulb is working. Re-install any racks you removed earlier.

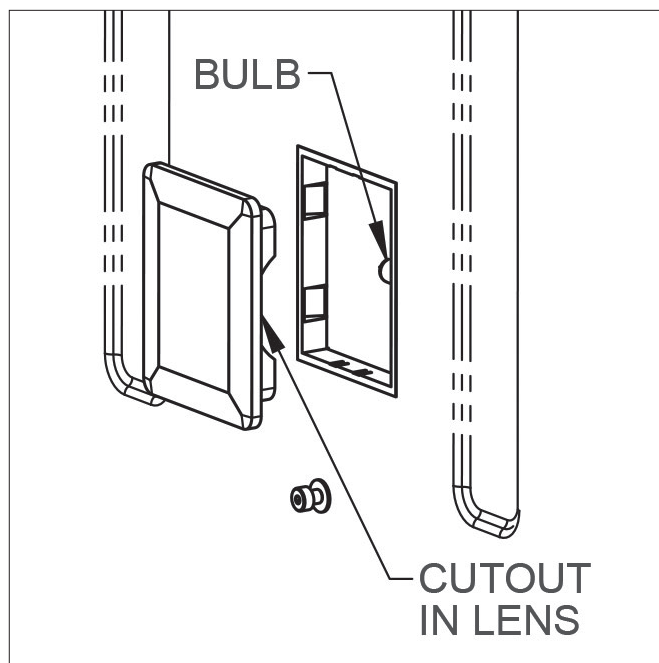

TROUBLESHOOTING GUIDE

Symptom	Possible Cause	Solution
Range does not operate (no knob lights, interior lights, etc.).	Power cord not plugged in, or no power to receptacle, or breaker tripped.	Check breaker. Call for service for other issues.
Burner will not light.	Gas supply not on / shutoff valve closed. Power cord not plugged in, or no power to receptacle, or breaker tripped. Burner ports near igniter, or igniter itself is obstructed or dirty. Burner head not installed correctly on base. Defective or clogged burner valve. Incorrect orifice or clogged orifice. Igniter defective (not sparking). Low gas pressure to unit. Defective regulator or regulator installed improperly.	Check shutoff valve. Check breaker. Call for service for other issues. Clean burner ports / igniter. Check burner head installation. Call for service.
Burner will not stay lit.	Burner ports obstructed or dirty. Vent plugged on regulator or regulator installed improperly. Low gas pressure.	Clean burner ports / igniter. Call for service.
Burner not working well / lazy or yellow flame.	Burner ports are obstructed or dirty. Poor combustion, air-fuel mixture not adjusted properly. Gas pressure incorrect / incorrect regulator. Orifice sized incorrectly for gas type.	Clean burner ports / igniter. Call for service.
Gas Odor.	Burner went out or did not light. Burner head not installed correctly on base. Burner ports obstructed or dirty. Loose or broken gas line. Ruptured pressure regulator. Poor combustion, air-fuel mixture not adjusted properly.	Relight burner. Check burner head installation. Clean burner ports / igniter. Turn shutoff valve to off position and call for service.
Oven Light not working.	Power cord not plugged in, or no power to receptacle, or breaker tripped. Bulb is burned out.	Check breaker. Call for service for other issues. Replace bulb.
Heat escaping from top of oven door.	Oven door not sealing correctly.	Check/clean oven door gasket. Replace if worn.
Fan noise / hot air coming from appliance, even when off.	Oven cooling down.	This is normal. If you DO NOT hear the fan running during or after using the oven, call for service.
Oven Mode and/or Oven Temperature backlight on or blinking	a) Power outage/power came on with one or more control knobs not OFF. b) Problem with controller or temperature sensing	Turn both controls OFF. If problem persists, call for service. Rangetop can still be used.

