



ASSEMBLY & OPERATING INSTRUCTIONS
MODEL #88787 BISON PREMIUM CHARCOAL GRILL



USA Edition 



TABLE OF CONTENTS	PAGE # 1
SAFETY INSTRUCTIONS	2
INSTALLATION INSTRUCTIONS	3
SPECIFICATIONS FOR BARBECUE STRUCTURE	3
OPERATING INSTRUCTIONS	4
EXCLUSIVE FEATURES	4
AFTER USE SAFETY	5
CLEANING & MAINTENANCE	6
CLEANING THE GRILL	6
CLEANING THE COOKING GRATES	6
PARTS LIST & EXPLODED ILLUSTRATION	7
LIMITED WARRANTY	8-10

REGISTERING YOUR GRILL

To validate your Bull Limited Warranty, you must submit the completed the Warranty Registration Card within 90 days from the date of purchase. Registration can be completed on-line at [Submit ticket \(ladesk.com\)](http://Submit ticket (ladesk.com)) or by sending the completed Warranty Registration Card and copy of your Purchase Receipt or Invoice as proof of purchase to:
BULL OUTDOOR PRODUCTS, INC.
 1011 East Pine St.
 Lodi, CA 95240
Attn: Warranty Service Center

For Warranty Claims or Replacement Parts ordering, please fill out the area provided below:

PRODUCT INFORMATION REFERENCE CARD

- Model Number _____
 - Serial Number _____
- (The Serial Number is encoded with essential information for ordering replacement parts or submitting Warranty claims. Location of Serial Numbers is shown below)
- Date of Purchase _____

LOCATION OF SERIAL NUMBERS

Essential information about your product is encoded in the serial number of your grill. This information will be required for all warranty claims, ordering replacement parts and will identify any variations of your unit. It is extremely important that you record your serial number and register your grill from the Proof of Purchase.

The grill serial number locations are shown below.

AT THE END OF YOUR GRILL'S BOX OR INSIDE OF BOX FLAP

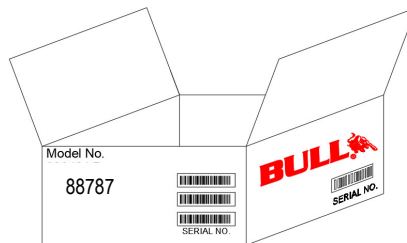



SAFETY INSTRUCTIONS

READ CAREFULLY BEFORE ASSEMBLY AND OPERATION OF YOUR GRILL

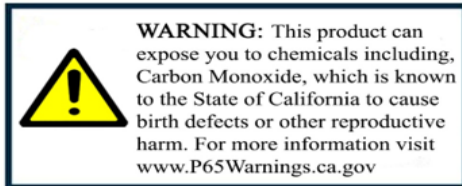

PROTECT CHILDREN:

- Do not allow children to operate the grill.
- Keep children away from the grill during use and until the grill has cooled after you are finished.

NEVER SMOKE DURING USE

SAFETY:

1. When using charcoal briquettes or wood chunks, form a pyramid and douse with lighter fluid. Wait until fluid has soaked in before lighting.
2. Cap lighter fluid immediately and place a safe distance from grill.
3. **Never** add lighter fluid to coals that are already hot or warm.
4. **Never** use gasoline, kerosene or other highly volatile fluids as a starter. They can explode.
5. As an alternative to lighter fluid, use an electric, solid or metal chimney or other starter specifically made for lighting charcoal briquettes or wood chunks.
6. Unplug and remove a hot starter with caution and be careful where you place it. Always make sure the starter is completely cool before storing.
7. **Never** use an electric starter in the rain and/or when standing on wet ground.
8. When using instant light briquettes, do not use lighter fluid, electric, solid or metal chimney-style starters. Do not add more instant light briquettes once the fire has been lit. Add only regular charcoal briquettes if more are needed.
9. Once the grill is lit, do not touch briquettes or wood chunks to see if they are hot. Keep grill uncovered until ready to cook.
10. Keep vents open while cooking. Charcoal briquettes and wood chunks need oxygen to burn.
11. Allow coals to burn out completely and let ashes cool at least 48 hours before disposing.
12. Dispose of cold ashes by wrapping in heavy-duty aluminum foil and placing in non-combustible container. Be sure no other combustible materials are nearby.
13. If you must dispose of ashes before completely cooled, place them in heavy-duty foil and soak with water completely before disposing in non-combustible container.

WARNING:

- This grill is designed for outdoor use only. If used indoors, toxic fumes will accumulate and cause serious bodily injury or death.
- **Do not** leave infants, children or pets unattended near a hot grill.
- **Do not** use grill near any combustible materials and/or chemicals. Combustible materials include, but are not limited to, wood or treated wood decks, patios or porches.
- Keep the grill in a level position at all times.
- Always put charcoal on top of the charcoal grate and not directly into the bottom of the bowl.
- Never touch the cooking or charcoal grate or the grill to see if they are hot.
- Use barbecue mitts or hot pads to protect hands while cooking or adjusting the vents.
- Use proper barbecuing tools with long, heat-resistant handles.
- Lining the bowl with aluminum foil will obstruct the air flow. Instead, use a drip pan to catch drippings from meat when cooking by the indirect method.



INSTALLATION INSTRUCTIONS

BISON INSTALLATION DIMENSIONS ARE IN (INCHES)

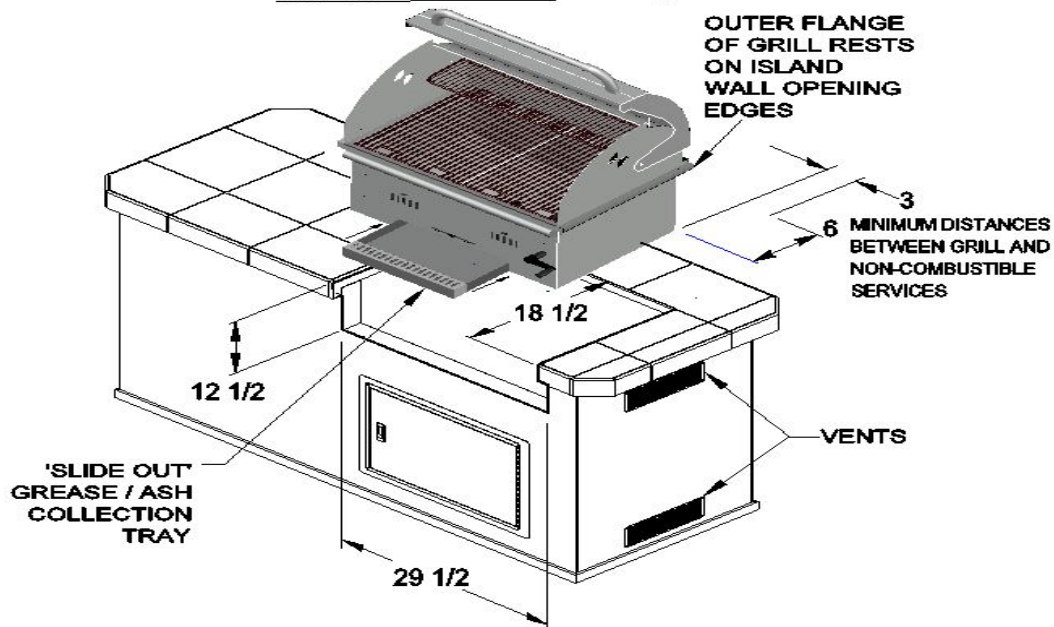

PLEASE READ THESE INSTRUCTIONS BEFORE INSTALLING YOUR CHARCOAL GRILL

Your charcoal grill comes to you fully assembled. These instructions and illustration will provide you with the measurements necessary for you or your builder to construct a masonry structure to house your outdoor charcoal grill.

THE LOCATION FOR YOUR GRILL

- **DO NOT** use your grill in garages, porches, breezeways, sheds or other enclosed areas.
- Your grill is to be used **OUTDOORS ONLY**, with at least **21 inches/54 cm/533.4 mm** clearance from the back and side of any combustible surface.
- The grill should **not** be placed under or on top of any surface that will burn.
- **DO NOT** obstruct the flow of combustion and ventilation air around the grill housing.

BISON INSTALLATION GUIDELINES AND SPECIFICATIONS:

Do not discard these instructions, retain for future reference.

The grill **MUST** be installed in accordance with all local building codes.

Grill Location:

When choosing a location for your grill, keep in mind that it should **never** be located under any overhead combustible construction.

Grill Cabinetry:

- Your charcoal grill **MUST** be installed in a cabinet constructed using only **non-combustible** materials.
- Any adjacent combustible materials **MUST** have a horizontal clearance of **21 inches** from the sides and back of the grill.
- 6 inches minimum clearance is required behind grill to allow front portion of hood to open and for ventilation purposes.
- Grill cabinet **MUST** have Upper and Ground level vents **MUST** be provided for combustion air on both sides of built-in cabinet.
- Vents on Grill insert **MUST** remain unobstructed to allow for combustion air and ventilation.
- The grill has a removable 15 1/2" x 14" x 2 1/2" ash collection box that must not be obstructed by cabinet construction.

Grill Installation: See illustration above for

- Cabinet wall opening dimensions required to install Grill into wall opening
- Do not use any combustible materials for this construction.



OPERATING INSTRUCTIONS

NOTE:

- Place the grill outdoors on a hard, level, non-combustible surface away from roof overhang or any combustible material.
- **Never** use on wood or other surfaces that could burn.
- Place the grill away from open windows or doors to prevent smoke from entering your house.
- Place the grill in an outdoor area that is protected from the wind.

CAUTION: DO NOT LEAVE GRILL UNATTENDED WHILE IN USE.

EXCLUSIVE FEATURES

- Air vent butterfly dampers at both sides of the lid control rate of burn for your choice of high intensity heat, slow roasting or smoking (see illustrations below).

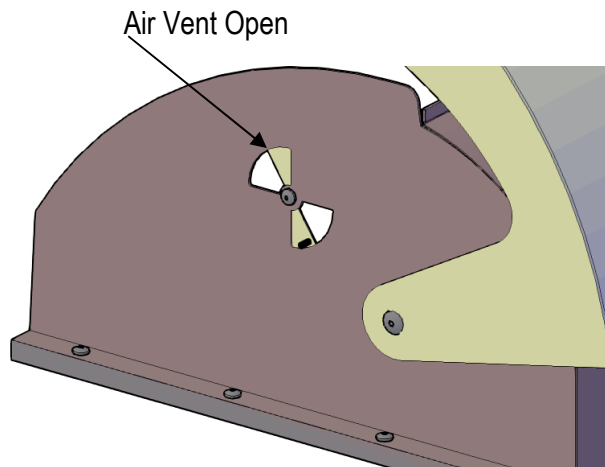
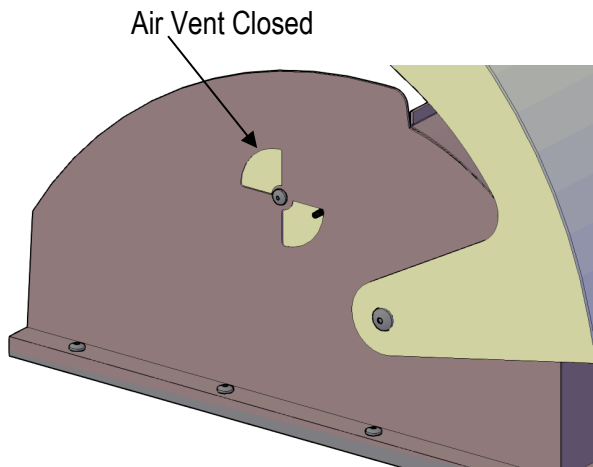

Grill door with air shutter can control the airflow (see illustrations below).

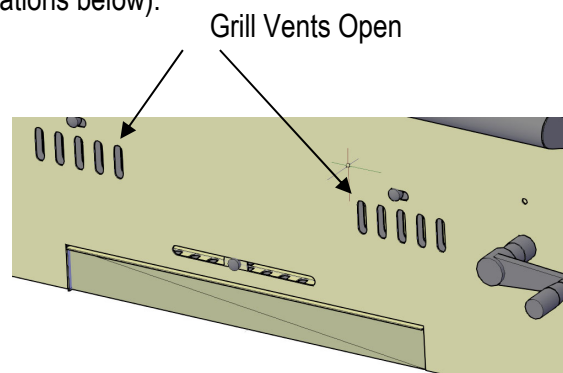
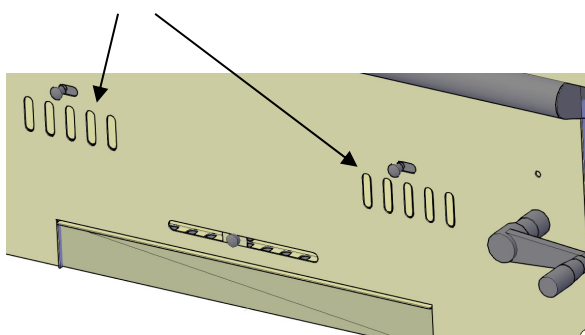



OPERATING INSTRUCTIONS (CONT.)

- Remove Cooking grill to access Charcoal holding trays to load Charcoal Briquets.

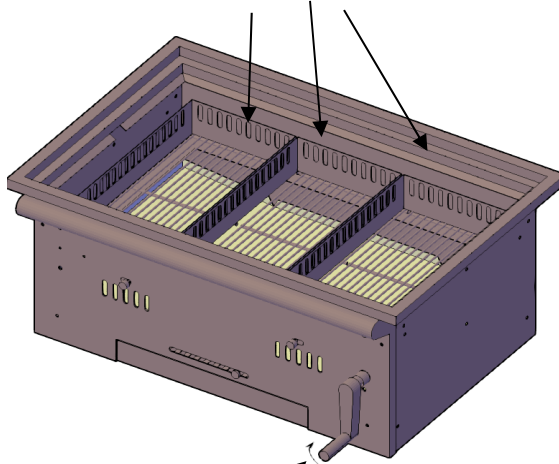

- Rotate the height adjustment knob to adjust the charcoal bed for multi-level heat control

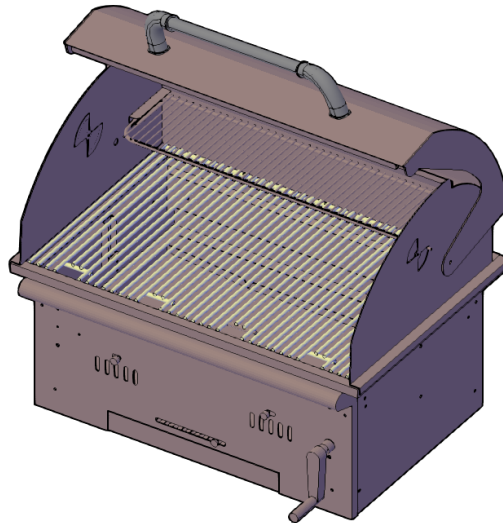

- Qty. 4 Cooking Grates

AFTER USE SAFETY:

- Always allow grill and all components to cool completely before handling.
- Never leave coals and ashes in grill unattended. Make sure coals and ashes are completely extinguished before removing.
- Before grill can be left unattended, remaining coals and ashes must be removed from grill. Place remaining coals and ashes in a non-combustible metal container and completely saturate with water. Allow coals and water to remain in metal container 24 hours prior to disposing.
- Extinguished coals and ashes should be placed a safe distance from all structures and combustible materials.
- With a garden hose, completely wet surface beneath and around the grill to extinguish any ashes, coals or embers which may have fallen during the cookout or cleaning process.
- Cover and store grill in a protected area away from children and pets.



PARTS LIST AND EXPLODED ILLUSTRATION

BISON PREMIUM GRILL PARTS LIST				
EXPLODED ILLUSTRATION ITEM #	BULL PART #	DESCRIPTION	QTY	WARRANTY PERIOD SHOWN IN YEARS
1	88703	BISON PREMIUM INSERT ASSEMBLY	1	5
2	88704	BISON PREMIUM CHARCOAL BED BRACKET	1	1
3	88705	BISON PREMIUM CHARCOAL GRID BRACKET	1	1
4	88708	CHARCOAL GRID ASSEMBLY PLATE	2	1
5	88706	BISON PREMIUM CHARCOAL GRID	3	1
6	88707	BISON PREMIUM CHARCOAL GRID FRAME	3	1
7	16517	COOKING GRATE	4	LIFETIME
8	88701	BISON PREMIUM HOOD - REAR	1	1
9	88700	BISON PREMIUM HOOD - FRONT	1	1
10	16509	TEMPERATURE GAUGE	1	1
11	16673	TEMPERATURE GAUGE BEZEL	1	1
12	67004	LID HANDLE CENTER BAR	1	1
13	16522	LID HANDLE END CAP	2	1
14	67007	WARMING RACK	1	1
15	88702	BISON PREMIUM HOOD AIR VENT BUTTERFLY DAMPER	2	1
16	88711	BISON PREMIUM GREASE/ASH TRAY	1	1
17	67027	ASH PAN DAMPER	1	1
18	88709	BISON PREMIUM HEIGHT ADJUSTMENT BOLT	1	1
19	88710	BISON PREMIUM HAND CRANK	1	1

