

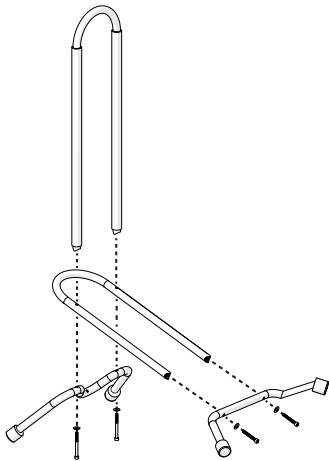

CAPSTONE FAT BIKE STAND ASSEMBLY INSTRUCTIONS

Thank you for purchasing the **CAPSTONE** fat bike stand. Please check all components according to the drawing included. If anything is missing, please contact an authorized dealer.

Size: Fits standard road bike tires through 5 inch wide fat bike tires.

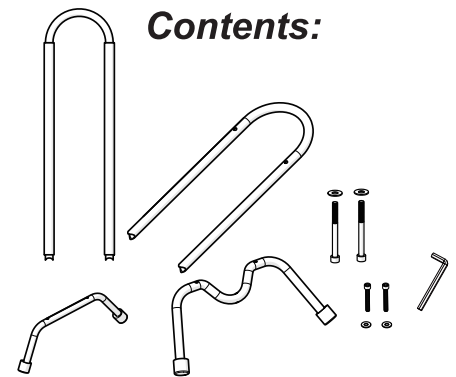
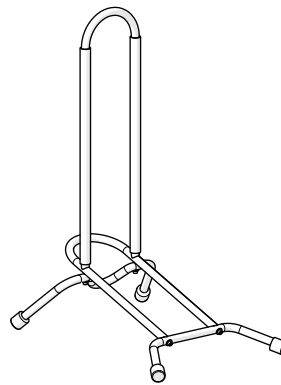

ASSEMBLY STEPS:

- Step 1:** Use the short bolts and washers to attach the rear leg to the base frame.
- Step 2:** Use the long bolts and washers to attach the front legs to the base frame and upward frame.
- Step 3:** Rotate rubber feet until bike stand sits level.

LIMITED LIFETIME WARRANTY

This Limited Warranty extends only to the original retail purchase, who must produce proof of purchase in order to validate any claim. This warranty is not transferable to anyone else.

What does this Limited Warranty cover? We offer our customer a limited lifetime warranty for main body of the bike stand from defects in material and workmanship and one year on degradable material like rubber and plastics from the date of the original purchase.

What must you do to keep the Limited Warranty in effect? This warranty is effective only if

- The bike stand is completely and correctly assembled.
- The bike stand is used under normal conditions for its intended purpose.

What is not covered by this Limited Warranty? This warranty does not include labor and transportation charges. This warranty does not cover normal wear and tear, paint, rust, normal maintenance items, personal injury, or any damage, failure or loss that is caused by accident, improper assembly, adjustment, storage, or use of the bike stand.

This Limited Warranty will be void if the bike stand is ever:

- Modified in any way.
- Rented or used for commercial purposes.

Kent International will not be liable for incidental or consequential loss or damage, due directly or indirectly from use of this product.

For how long does this Limited Warranty last? The main body is warranted for the usable life of the bike stand. Kent International will replace the main body at no charge, should it fail in any weld point when the stand has been used in a normal manner, and determined by our inspection. You must receive prior authorization from Kent Customer Service, before returning any product or parts. All other components are warranted against defects for one year from the date of purchase when properly assembled and used in a normal manner.

What will Kent do? It is under our discretion or determine which of the following methods is most suitable to execute the warranty: repair, replacement, or refund. CONSUMER MUST PAY ALL LABOR AND TRANSPORTATION CHARGES CONNECTED WITH THE REPAIR OR WARRANTY WORK.

How do you get service? Phone the Customer Service Department (8am - 4pm E.S.T.) at 1-800-451-KENT. All warranty claims should be made to Kent International, Inc. 60 E. Halsey Rd. Parsippany, NJ 07054 USA.

What rights do you have? This limited warranty gives you specific legal rights. You may also have other rights which vary from State to State.

FOR SERVICE ASSISTANCE, CALL TOLL FREE 1.800.451.5368