

NATIONAL-SPENCER, INC.

ZEE LINE LUBRICATION EQUIPMENT

Phone 800-231-1525

Fax 800-637-9511

Web Address www.zeeline.com



Part #333

Variable Stroke Grease Pump With Bearing Packer

For packing bearings up to 6"
diameter

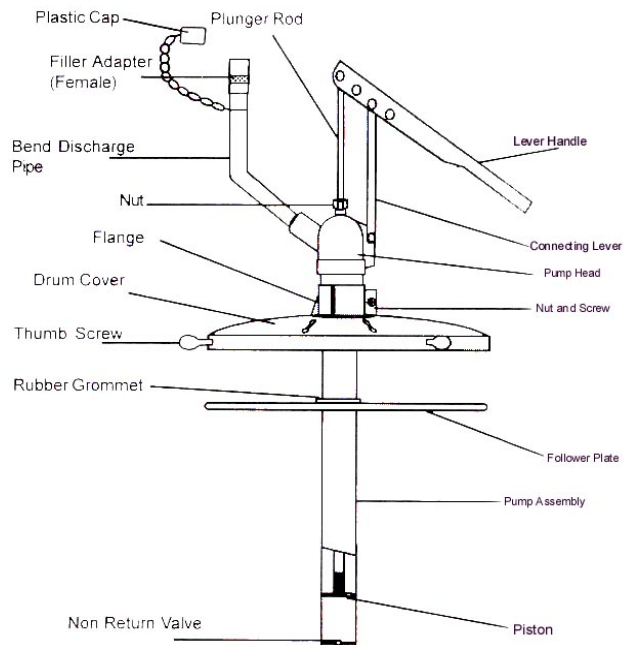

Features

- ❖ Fits 25 to 50 lb. container
- ❖ Bearing packer included
- ❖ Pump length 18"
- ❖ Drum cover diameter 12"
- ❖ Rubber lined follower plate
- ❖ Zinc plated pump
- ❖ Zinc die cast head
- ❖ Cast aluminum adjusting flange, cover
- ❖ Female loader adapter
- ❖ Adjustable pivot point allows for delivery of up to 14 oz. per each 15 strokes

Recommended for

- ✓ Packing bearings up to 6" diameter

Application

- Automotive
- Industrial
- Agricultural

Number of boxes and contents

- ❑ 1 box (23" x 13" x 4") (12 lb.)
- ❑ UPC Code 0 1595400333 5

