



When You Need A Hand Up[®]

Richbury Pty Ltd ABN 37 010 365 474
 90B Northgate Drive Thomastown Victoria 3074
 P (03) 9466 3211
 F (03) 9466 3200
 Email: sales@handrailindustries.com.au
www.handrailindustries.com.au



TYPE 522

960MM Wide Folding Shower Seat

White acrylic anti-slip seat top with stainless steel legs.

Complies with AS 1428

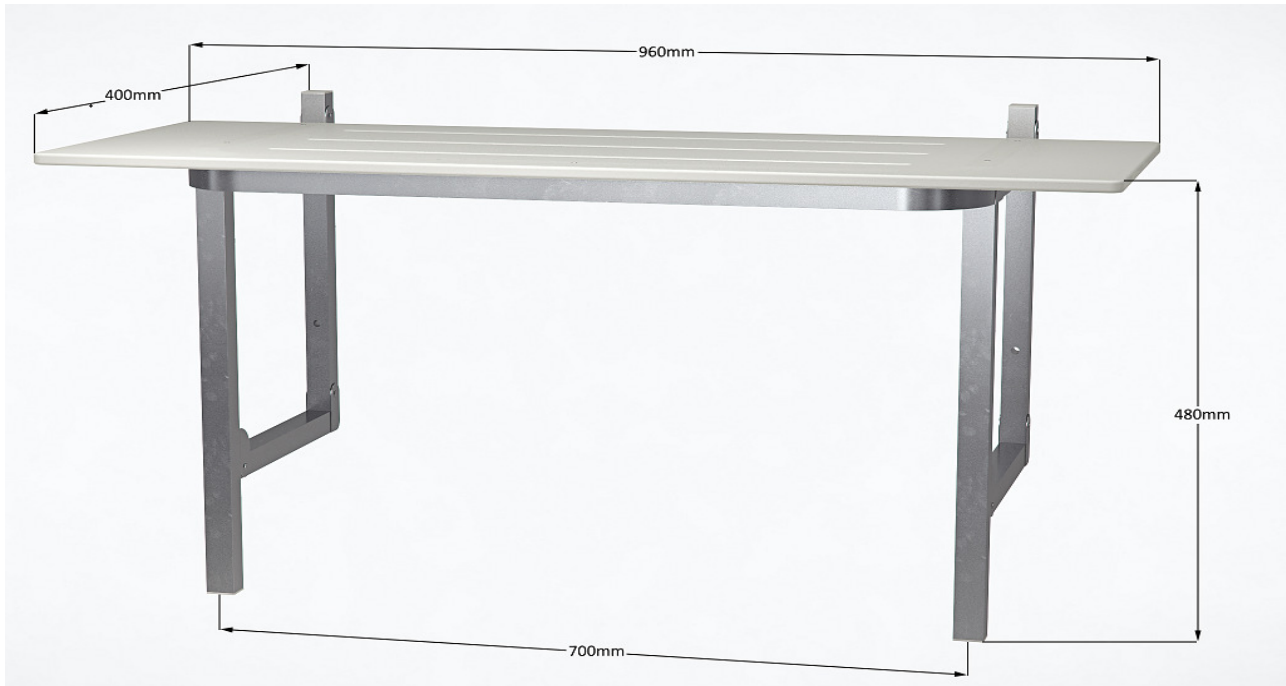

FIXING DETAILS FOR SHOWER SEATS	
CAT. No.:	Brackets Centre to Centre
TYPE 518	325MM
TYPE 520	475MM
TYPE 522	700MM
TYPE 522	700MM

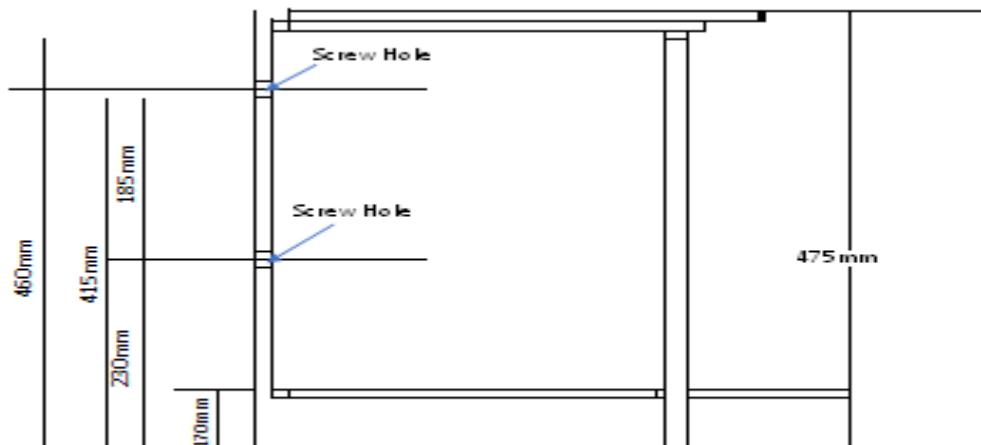



When You Need A Hand Up'

Richbury Pty Ltd ABN 37 010 365 474
90B Northgate Drive Thomastown Victoria 3074
P (03) 9466 3211
F (03) 9466 3200
Email: sales@handrailindustries.com.au
www.handrailindustries.com.au



GEC 24602
ISO 9001

TGA Registered
Independently Certified to Australian Standard 1428.1.2009

TYPE 522 SHOWER SEAT LOAD TEST

On August 24th, 2011 Hand Rail Industries carried out a load test on our Type 522 Folding Shower Seat. This test was performed under normal installation conditions by loading weights totaling 206kg centrally on the seat top.

No Distortion of flexing in the brackets was evident. The seat top flexed 8mm at the centre and returned to its original condition on removal of the weights.

No welding or material failure occurred to either the brackets or seat top.

