

Installation Instructions

MODEL STRAIGHT GRAB RAIL

AS1428.1:2021 Compliant

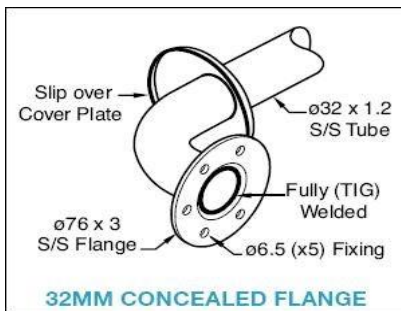

Description:

Straight Grab Rail for use in disabled, aged care facilities and home assist use. For lengths over 1200 a centre support bracket is included for extra strength.

Models:

300mm, 450mm, 600mm, 750mm, 800mm, 950mm, 1200mm

Materials:

304 Grade Satin Stainless Steel tubing.
76 x 3mm Concealed Flange

To meet requirements of AS1428.1-2021

1. Install at height of 800-820mm to top of rail from floor level.
2. Fixings need to be able to withstand a force of 1100N applied at any position and in any direction.
3. Clearance between grabrail and the adjacent wall surface or obstruction shall be not less than 50mm or more than 60mm.

The wall to the inside of the rail is 55mm on standard Hand Rail Industries Rails.

Note: To the extent permitted by law Hand Rail Industries does not provide any warranty in relation to bolts, screws or other fasteners provided with Hand Rail Industries products. You should obtain appropriate advice from a licensed trade person before affixing or installing.

90B Northgate Drive VIC 3074

Phone: (03) 9466 3211 Fax: (03) 9466 3200

Email: sales@handrailindustries.com.au Web: www.handrailindustries.com.au