

256C32/257C32

Product Specification

Specification

Fully welded construction in grade 304 stainless steel tube, 32mm diameter. Slip resistant Satin Stainless Steel with flange covers. Easy to install on most building surfaces designed for maximum strength and user confidence. 1000mm x 760mm x 1100mm Vertical one piece grab rail. Conforms to AS1428.1:2021. Hand Rail Industries™ products are made to the highest standards and currently the only TGA registered grab rail manufacturer in Australia.

Options

Polished stainless steel, powder coated finish, knurled finishes. Available in Clean Seal flange system, and Exposed fix.

Guarantee

Hand Rail Industries™ products are fully guaranteed against faulty workmanship and material defects subject to normal wear and tear of the product for a period of 5 years.

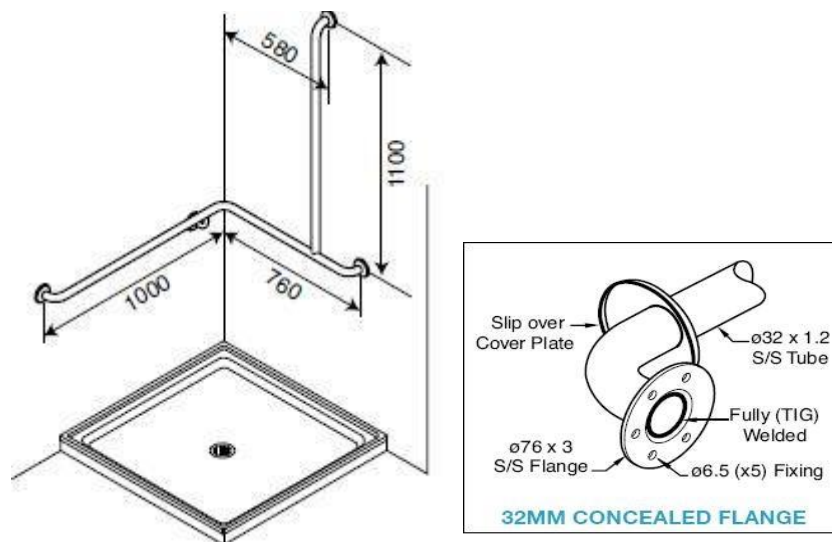

Right Hand Image Shown / 257C32 Left Hand Opposite to Shown

HAND RAIL INDUSTRIES

90B Northgate Drive, Thomastown. Vic. 3074
Phone: (03) 9466 3211 | Fax: (03) 9466 3200
Email: sales@handrailindustries.com.au |
Web: www.handrailindustries.com.au