

108C32/109C32

Product Specification

Specification

Fully welded construction in grade 304 stainless steel 32mm diameter tube. Slip resistant Satin Stainless Steel with flange covers. Easy to install on most building surfaces designed for maximum strength and user confidence. Length 450mm x 700mm, 40 degree angle WC one piece Ambulant Grab Rail. Hand Rail Industries™ products are made to the highest standards and currently the only TGA registered Grab Rail manufacturer in Australia.

Options

Polished stainless steel, powder coated, 1428 knurled finish. Also available in Clean Seal flange system and Exposed Fix.

Guarantee

Hand Rail Industries™ products are fully guaranteed against faulty workmanship and material defects subject to normal wear and tear of the product for a period of 5 years.

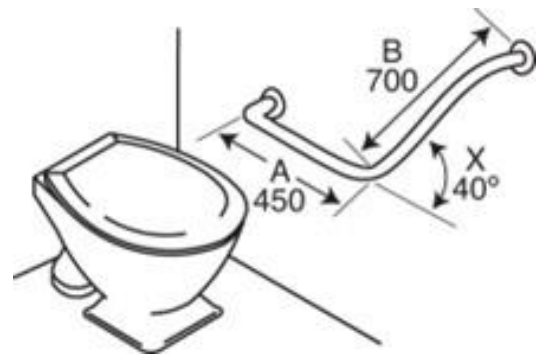
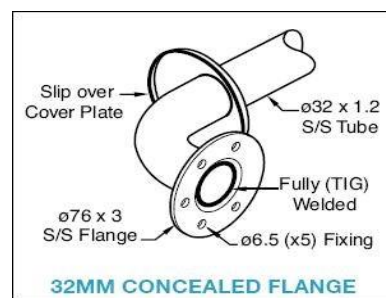

Left Hand Image Shown
109C32 Right Hand Opposite to shown



HAND RAIL INDUSTRIES

90B Northgate Drive, Thomastown. Vic. 3074
Phone: (03) 9466 3211 | Fax: (03) 9466 3200
Email: sales@handrailindustries.com.au
Web: www.handrailindustries.com.au