

FIREMAGIC®

CHOICE

STAND-ALONE POST OUTDOOR GAS GRILLS

C430s (IN-GROUND AND PATIO MOUNT)

INSTALLATION AND OWNER'S MANUAL

INSTALLER: Leave these instructions with consumer.

CONSUMER: Retain for future reference.

Patio mount
shown



IMPORTANT: READ THESE INSTRUCTIONS CAREFULLY BEFORE STARTING INSTALLATION OR USE.

SAFETY AND WARNING CODES

⚠ DANGER:

IF YOU SMELL GAS:

1. Shut off the gas to the appliance.
2. Extinguish any open flame.
3. Open lid.
4. If odor continues, keep away from the appliance and **immediately** call your gas supplier or the fire department.

CODE AND SUPPLY REQUIREMENTS: This grill must be installed in accordance with local codes and ordinances, or, in the absence of local codes, with either the latest *National Fuel Gas Code (ANSI Z223.1/NFPA 54)*, and *Natural Gas and Propane Storage and Handling Installation Code (CSA-B149.1)*.

This appliance and its dedicated manual shutoff valve must be disconnected from the gas-supply piping system when testing the system at pressures in excess of ½ psig (3.5 kPa).

This appliance must be isolated from the gas-supply piping system by closing its dedicated manual shutoff valve during any pressure testing of the gas-supply system at pressures up to and including ½ psig (3.5 kPa).

Proper operation of your grill requires prompt and periodic maintenance. See the SERVICING AND CLEANING section for details.

⚠ WARNING:

1. Do not store or use gasoline or other flammable vapors and liquids in the vicinity of this or any other appliance.
2. An LP cylinder not connected for use shall not be stored in the vicinity of this or any other appliance.

⚠ WARNING:

Improper installation, adjustment, alteration, service, or maintenance can cause injury or property damage. For proper installation, refer to the installation instructions. For assistance or additional information, consult a qualified professional service technician, service agency, or the gas supplier.

All electrical outlets in the vicinity of the grill must be properly grounded in accordance with local codes, or, in the absence of local codes, with the *National Electrical Code, ANSI/NFPA 70*, or the *Canadian Electrical Code, CSA C22.1*, whichever is applicable.

Keep all electrical-supply cords and fuel-supply hoses away from any heated surface.



Certified to: ANSI Z21.58
CSA 1.6

- INSTALLATION INSTRUCTIONS ET MANUEL DU PROPRIÉTAIRE -

GRIL EXTÉRIEUR DE GAZ

IMPORTANT: LISEZ CES INSTRUCTIONS SOIGNEUSEMENT AVANT DE COMMENCER L'INSTALLATION OU L'UTILISATION

SÛRETÉ ET CODES D'AVERTISSEMENT

▲ DANGER:

SI VOUS SENTEZ LE GAZ :

1. Coupez le gaz à l'appareil.
2. Éteignez-vous n'importe quelle flamme nue.
3. Ouvrez le couvercle si équipé d'un four.
4. Si l'odeur continue, gardez loin de l'appareil et appelez immédiatement votre département de fournisseur ou de feu de gaz.

CONDITIONS DE CODE ET D'APPROVISIONNEMENT:

Ce gril doit être installé selon des codes et des ordonnances locaux, ou, en l'absence des codes locaux, avec l'un ou l'autre le plus défunt *Code national de gaz de carburant* (norme ANSI Z223.1/NFPA 54), et *Stockage de gaz naturel et de propane et manipulation du code d'installation* (CSA-B149.1).

Cet appareil et ses différents robinets d'isolement doivent être démontés du gaz-fournissent le système sifflant en examinant le système aux pressions au-dessus du ½ psig (kPa 3.5).

Cet appareil doit être isolé dans gaz-fournissent le système sifflant par fermeture que ses différents robinets d'isolement manuels pendant tous les essais sous pression du gaz-fournissent le système aux pressions jusques et y compris le ½ psig (kPa 3.5).

- Ce gril est pour utilisation à l'extérieur seulement. Si l'appareil est entreposé à l'intérieur, enlever les bouteilles et les laisser à l'extérieur.
- Ne pas ranger le gril immédiatement après l'avoir utilisé. le laisser refroidir avant de le déplacer ou de la ranger. Le non respect de cette mesure de sécurité pourrait entraîner un incendie causant des dommages à la propriété, des blessures ou la mort.
- Ne pas utiliser cet appareil sous une surface combustible.
- Ne pas utiliser cet appareil sous un auvent. Le non respect de cette mesure de sécurité pourrait entraîner un incendie ou des blessures.
- Dégagement minimal entre les parois latérales et l'arrière de l'appareil et la construction combustible (45.7 cm à partir des parois latérales et 45.7cm à partir de l'arrière).
- Le régulateur de pression de gaz prévu avec cet appareil de cuisson à gaz pour l'extérieur doit être utilisé. Ce régulateur est réglé pour une pression de sortie de 5 pouces de colonne de l'eau pour le gaz naturel, et 10 pouces pour le propane.
- LE RÉGULATEUR INCLUS D'APPAREILS EST ÉVALUÉ POUR LE MAXIMUM DE 1/2 (LIVRES PAR POUCE CARRÉ). SI VOTRE OFFRE DE GAZ EST 1/2 PLUS GRAND QUE (LIVRES PAR POUCE CARRÉ), UN RÉGULATEUR ADDITIONNEL DOIT ÊTRE INSTALLÉ AVANT LE GRIL. VOIR LA SECTION DE CONDITIONS

▲ AVERTISSEMENT:

1. Ne stockez pas ou n'employez pas l'essence ou d'autres vapeurs et liquides inflammables à proximité de ceci ou d'aucun autre appareil.
2. Un cylindre de propane non relié pour l'usage ne sera pas stocké à proximité de ceci ou d'aucun autre appareil.

▲ AVERTISSEMENT:

L'installation inexacte, l'ajustement, le changement, le service, ou l'entretien peuvent causer des dommages ou des dégâts matériels. Référez-vous à ce manuel. Pour de l'aide ou des renseignements supplémentaires, consulter un technicien professionnel qualifié de service, une agence de service ou le fournisseur de gaz.

Toutes les sorties électriques à proximité du gril doivent être correctement fondues selon des codes locaux, ou en l'absence de local code, avec le code électrique national, ANSI/NFPA 70, ou le code électrique canadien, CSA C22.1, celui qui est applicable.

Maintenez tout électrique-fournissent des cordes et carburant-fournissent des tuyaux partis de n'importe quelle surface de chauffage.

D'OFFRE DE GAZ POUR LA PRESSION APPROPRIÉE D'OFFRE DE GAZ.

- Ne couvrez jamais la surface entière de cuisine ou de gril de gauffreuses ou de casseroles. La surchauffe se produira et les brûleurs ne seront pas très performants quand la chaleur de combustion est emprisonnée au-dessous de la surface à cuire.
- Ne pulvérisez jamais l'eau sur une unité chaude de gaz, comme ceci peut endommager des composants de porcelaine ou de fer de fonte.
- Une fuite de GPL peut causer un incendie ou une explosion si enflammée entraînant des blessures corporelles graves ou la mort.
- Communiquez avec le fournisseur de GPL pour les réparations ou pour disposer de qules bouteille ou du GPL non utilisé.

Certifié à la norme: ANSI Z21.58 / CSA 1.6

INSTALLATEUR : Laissez ces instructions avec le consommateur.
CONSOMMATEUR : Maintenez pour la future référence.

GETTING STARTED

INSTALLATION, OPERATION, AND SAFETY INFORMATION	4
GAS SAFETY INFORMATION	5
<i>WARNING</i>	5
<i>WHEN USING PROPANE GAS</i>	5
<i>WHEN USING NATURAL GAS</i>	5
<i>INSTALLATION SAFETY GUIDELINES</i>	5
OPERATING THE UNIT SAFELY AND CORRECTLY	5
SAFE USE & MAINTENANCE OF PROPANE GAS CYLINDERS	7
INSTALLATION REQUIREMENTS	8
<i>OVERHEAD CONSTRUCTION AND EXHAUST HOOD REQUIREMENTS</i>	8
<i>SIDE AND REAR WALL CLEARANCES</i>	9
<i>ENSURE PROPER COMBUSTION AIR AND COOLING AIRFLOW</i>	10
<i>GAS-SUPPLY PLUMBING REQUIREMENTS</i>	10
MODEL SPECIFICATIONS	11
REPLACEMENT PARTS LIST	14

INSTALLATION

PATIO MOUNT INSTALLATION	16
IN-GROUND POST INSTALLATION	18
<i>INSTALL THE FLAVOR GRIDS</i>	21
<i>INSTALL THE COOKING GRIDS</i>	21
<i>INSTALL THE DRIP TRAY</i>	21
<i>INSTALL THE RIGID SHELVES</i>	22

USE, CARE, & SERVICE

IDENTIFICATION OF GRILL CONTROLS	23
USING THE GRILL	24
LIGHTING (IGNITION) INSTRUCTIONS	25
<i>ELECTRONIC LIGHTING</i>	25
<i>MANUAL LIGHTING</i>	25
<i>SETTING THE TIMER</i>	25
<i>SHUTTING OFF THE UNIT</i>	25
SERVICING AND CLEANING	27
<i>CONVERTING THE GAS TYPE</i>	28
<i>BURNER AIR SHUTTER ADJUSTMENT</i>	29
<i>CONTROL PANEL REMOVAL</i>	30
<i>IGNITER BATTERY REPLACEMENT</i>	31
NOTES PAGE	32
TROUBLESHOOTING.....	33
WARRANTY	34

INSTALLATION, OPERATION, AND SAFETY INFORMATION

1. The outdoor appliance and surrounding area **MUST** remain clear of flammable substances such as gasoline, yard debris, wood, etc.
2. Do not block the 1" front air inlet along the bottom of the control panel.
3. **This unit must be installed so that the vent openings and surrounding area of the grill remain clear and free at all times. See the GAS SAFETY INFORMATION section.**
4. **When using propane gas: the propane cylinder, regulator, and rubber hose must be in a location not subject to temperatures above 125° F (51° C).**
5. The flames on each burner burn evenly along the entire burner with a steady flame (mostly blue). If burner flames are not normal, check and clean the orifice and burner/venturi tubes for insects and insect nests. A clogged tube can lead to a fire beneath the unit. A proper flame pattern will ensure safe operation and optimal performance. Adjust the air shutter as needed (see **SERVICING AND CLEANING, AIR SHUTTER ADJUSTMENT**).
6. The in-line gas valve or gas cylinder valve must always be shut OFF when the unit is not in use.
7. The drip collector holes must be clear and unobstructed. Excessive grease deposits can result in a grease fire.

IMPORTANT

IN THE EVENT OF A GREASE FIRE, IMMEDIATELY SHUT OFF THE MAIN GAS VALVE TO THE UNIT. KEEP THE LID OPEN AND ALLOW THE FIRE TO EXTINGUISH ITSELF. A THOROUGH INSPECTION BY A TRAINED SERVICE TECHNICIAN SHOULD BE CONDUCTED BEFORE FUTURE USE OF YOUR UNIT. THE SERVICE TECHNICIAN WILL CHECK THE SYSTEM FOR GAS LEAKS AND WILL CHECK ALL ELECTRICAL WIRING FOR DAMAGE. ALL GAS LEAKS AND WIRING MUST BE REPAIRED PRIOR TO FUTURE USE.

WARNING: NEVER cover more than 75% of the cooking or grill surface with griddles or pans. Overheating will occur, and burners will not perform properly when combustion heat is trapped below the cooking surface.

CAUTION: NEVER spray water on a hot gas unit.

The grill serial number tag can be found affixed to the grill body behind the control panel (on an aluminum tag) and on the underside of the drip tray handle (on a thermal label). It is recommended that the drip tray first be removed and cleaned / emptied of its contents, then turned over to view. The unit rating label is located inside of the control panel.

GAS SAFETY INFORMATION

WHEN OPERATING THIS GAS APPLIANCE, ALL INSTRUCTIONS AND WARNINGS MUST BE OBSERVED. FAILURE TO DO SO MAY RESULT IN A FIRE OR EXPLOSION CAUSING PROPERTY DAMAGE, BODILY INJURY, OR DEATH.

WARNING

This appliance **MUST** be installed and operated according to the information below.

FAILURE TO PROPERLY VENT THE PROPANE TANK MAY RESULT IN A FIRE OR EXPLOSION CAUSING PROPERTY DAMAGE, BODILY INJURY, OR DEATH.

A leaking gas connection or valve unintentionally left open will create a hazard.

WHEN USING PROPANE GAS

- **Propane gas** (also known as **L.P. gas**) is heavier than air and will accumulate or pool in an inadequately vented area or recessed area.
- If a pool of **propane gas** is ignited, an explosion will occur. Adequate venting at the floor level of the propane tank eliminates this danger.
- DO NOT store a spare propane-gas cylinder near the unit.

WHEN USING NATURAL GAS

- **Natural gas** is lighter than air and will accumulate at the top of an inadequately vented area.
- If an accumulation of **natural gas** is ignited, an explosion will occur. Adequate venting will eliminate this danger.

INSTALLATION SAFETY GUIDELINES

THIS UNIT MUST BE INSTALLED SO THAT THE AREA AROUND THE UNIT AND PROPANE TANK REMAIN CLEAR AND FREE AT ALL TIMES.

The gas cylinder, regulator, and rubber hose must be in a location not subject to temperatures above 125° F (51° C).

IF A PROPANE CYLINDER IS INSTALLED, THE GUIDELINES FOUND IN THE SAFE USE & MAINTENANCE OF PROPANE GAS CYLINDERS SECTION MUST BE FOLLOWED.

OPERATING THE UNIT SAFELY AND CORRECTLY

Every time you use the unit, **make sure that:**

1. The area around the unit is clear and free from combustible materials, gasoline and flammable vapors/liquids.
2. There is no blockage of the airflow around the unit and propane tank.
3. The hose is inspected (if applicable). See SAFE USE & MAINTENANCE OF PROPANE-GAS CYLINDERS section.

DO NOT store any combustible materials, gasoline, and any other flammable vapors/liquids in the vicinity of the unit. Provide adequate clearance for servicing and operation.

UTILISATION SÛRE ET ENTRETIEN DES CYLINDRES DE GAZ DE PROPANE

IMPORTANT POUR VOTRE SÛRETÉ

LISEZ ET SUIVEZ TOUS LES AVERTISSEMENTS ÉQUIPÉS DE VOTRE CYLINDRE DE GAZ DE PROPANE.

En actionnant cet appareil avec un cylindre de gaz de propane ON DOIT observer ces instructions et avertissements.

LE MANQUE DE FAIRE AINSI PEUT AVOIR COMME CONSÉQUENCE UNE INCENDIE OU UNE EXPLOSION SÉRIEUSE.

CYLINDRE ET CONDITIONS ET

CARACTÉRISTIQUES DE CONNECTEUR

- Des cylindres et les valves de gaz de propane doivent être maintenus en bon état et doivent être remplacés s'il y a des dommages évidents au cylindre ou à la valve.
- Ce gril, une fois utilisé avec un cylindre, devrait être relié à un gallon de la norme 5 (20lb.) cylindre de gaz de propane équipé d'un OPD (remplissez au-dessus du niveau le dispositif d'empêchement). L'OPD a été exigé sur tous les cylindres vendus depuis octobre 1.1998 pour empêcher le remplissage excessif.
- Les dimensions de cylindre devraient être approximativement 12" (30.5cm) de diamètre et 18" (45.7cm) hauts. Des cylindres doivent être construits et marqués selon les caractéristiques pour des cylindres de gaz de propane du département des ETATS-UNIS du transport (D.O.T.) ou le niveau national du Canada, du CAN/CSA-B339, des cylindres, des sphères et des tubes pour le transport des marchandises dangereuses.
- Le cylindre doit inclure un collier pour protéger la valve de cylindre et le circuit d'alimentation de cylindre doit être assuré le retrait de vapeur.
- Le régulateur de pression et l'ensemble de tuyau utilisé doivent assortir les spécifications pour le type I par ANSI Z 21.58/CGA 1.6 (voir la fig. 6-1).
- La valve de cylindre de gaz de propane doit être équipée d'un dispositif d'accouplement de raccordement de cylindre, décrit comme type I dans la norme définie dans le e. de paragraphe ci-dessus. Ce dispositif est généralement décrit comme coupleur rapide de fil de point culminant.
- Si votre cylindre de gaz de propane vient avec une prise de la poussière, placez le bouchon anti-poussière sur la sortie de valve de cylindre toutes les fois que le cylindre n'est pas en service.

OPÉRATION DE COUPLEUR RAPIDE

Pour relier le régulateur/hose à l'ajustage de précision de valve de cylindre de gaz de propane: Serrez l'écrou de main sur le régulateur au-dessus de l'ajustage de précision de fil de point culminant sur la valve de cylindre. Tournez l'écrou de

main dans le sens des aiguilles d'une montre pour engager les fils et pour serrer jusqu'à ce que douillettement. L'utilisation des pinces ou de la clé ne devrait pas être nécessaire. Seulement le propane marqué par cylindres doit être employé.

Pour débrancher: Tournez l'écrou de main dans le sens contraire des aiguilles d'une montre jusqu'à isolé (fig. 6-1).

Important: Avant d'employer le gril, et ensuite chaque fois que le cylindre est enlevé et rattaché, examinez tous les raccordements pour déceler les fuites. Arrêtez les valves de gril et ouvrez la valve principale de cylindre, puis vérifiez les raccordements avec de l'eau savonneux. Réparez toutes les fuites avant d'allumer le gril.

ATTENTION: Tournez toujours la valve principale de cylindre de propane au loin après chaque utilisation, et avant de déplacer le gril et le cylindre, ou débrancher l'accouplement. Cette valve doit rester fermée et le cylindre a débranché alors que l'appareil n'est pas en service, quoique l'écoulement de gaz soit arrêté par un dispositif de sûreté quand le coupleur est débranché.

Inspectez soigneusement l'ensemble de tuyau chaque fois avant que le gaz soit allumé. Un tuyau fissuré ou effiloché doit être immédiatement remplacé.

Si l'appareil est stocké à l'intérieur, le cylindre doit être disconnected et a enlevé. Des cylindres Disconnected doivent être stockés dehors, hors de la portée des enfants, avec les prises de valve filettées étroitement installées, et ne doivent pas être stockés dans un bâtiment, le garage, ou n'importe quel autre secteur inclus.

POUR VOTRE SÛRETÉ

- Ne stockez pas un cylindre de gaz disponible de propane dessous ou ne vous approchez pas de cet appareil.
- Ne remplissez jamais cylindre au delà de 80 pour cent de plein.
- SI L'INFORMATION DANS "A" ET "B" N'EST PAS SUIVIE EXACTEMENT, UN FEU CAUSANT LA MORT OU DES DOMMAGES SÉRIEUX PEUT SE PRODUIRE.

Fig. 6-1 type coupleur rapide de fil de point culminant d'I

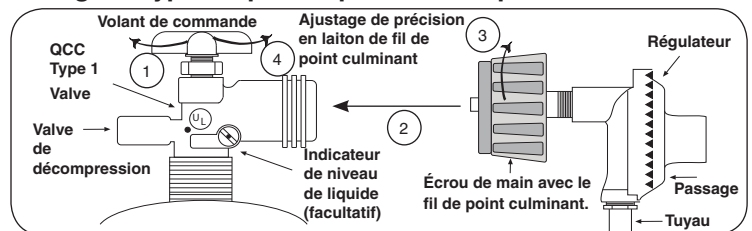

SAFE USE & MAINTENANCE OF PROPANE GAS CYLINDERS

IMPORTANT FOR YOUR SAFETY

READ AND FOLLOW ALL WARNINGS PROVIDED WITH THE PROPANE-GAS CYLINDER.

When operating this appliance with a propane-gas cylinder, these instructions and warnings **MUST** be observed.

FAILURE TO DO SO MAY RESULT IN A SERIOUS FIRE OR EXPLOSION.

CYLINDER/CONNECTOR REQUIREMENTS

- a. Propane-gas cylinders, valves, and hoses must be maintained in good condition and must be replaced if there is visible damage to either the cylinder or valve. If the hose is cut or shows excessive abrasion or wear, it must be replaced before using the gas appliance (see e.).
- b. This unit, when used with a cylinder, should be connected to a standard 5-gallon (20 lb.) propane-gas cylinder equipped with an OPD (Overfill Prevention Device). The OPD has been required on all cylinders sold since October 1, 1998, to prevent overfilling.
- c. Cylinder dimensions should be approximately 12" (30.5 cm) in diameter and 18" (45.7 cm) high. Cylinders must be constructed and marked in accordance with the *Specifications for Propane Gas Cylinders of the U.S. Department of Transportation (D.O.T.)* or the National Standard of Canada, *CAN/CSA-B339, Cylinders, Spheres, and Tubes for Transportation of Dangerous Goods*.
- d. The cylinder used must include a collar to protect the cylinder valve, and the cylinder supply system must be arranged for vapor withdrawal.
- e. The pressure regulator and hose assembly used must match the specification for Type I by *ANSI Z 21.58/CGA 1.6* (see Fig. 7-1).
- f. The propane-gas cylinder valve must be equipped with a cylinder connection coupling device, described as Type I in the standard defined in paragraph e. above. This device is commonly described as an Acme thread quick coupler.
- g. If the propane-gas cylinder comes with a dust plug, place the dust cap on the cylinder valve outlet whenever the cylinder is not in use.

QUICK COUPLER OPERATION

To connect the regulator/hose assembly to the propane-gas cylinder valve fitting: Press the hand nut on the regulator over the Acme thread fitting on the cylinder valve. Turn the hand nut clockwise to engage the threads and tighten until snug.

The use of pliers or a wrench should not be necessary. Only cylinders marked "propane" may be used.

To disconnect: Turn the hand nut counterclockwise until detached (Fig. 7-1).

Important: Before using the unit, and after each time the cylinder is removed and reattached, check the hose for wear (see a.) and check all connections for leaks. Turn off the unit valves and open the main cylinder valve, then check connections with soapy water. Repair any leaks before lighting the unit.

CAUTION: Always turn the propane cylinder main valve off after each use, and before moving the unit and cylinder or disconnecting the coupling. This valve must remain closed and the cylinder disconnected while the appliance is not in use, even though the gas flow is stopped by a safety feature when the coupler is disconnected.

Carefully inspect the hose assembly each time before the gas is turned on. A cracked or frayed hose must be replaced immediately.

If the appliance is stored indoors, the cylinder must be disconnected and removed. Disconnected cylinders must be stored outdoors, out of the reach of children, with threaded valve plugs tightly installed, and must not be stored in a building, garage, or any other enclosed area.

FOR YOUR SAFETY

- a. DO NOT store a spare propane-gas cylinder under or near this appliance.
- b. NEVER fill the cylinder beyond 80-percent full.
- c. IF THE INFORMATION IN a. AND b. IS NOT FOLLOWED EXACTLY, A FIRE CAUSING DEATH OR SERIOUS INJURY MAY OCCUR.

Fig. 7-1 Type I Acme thread quick coupler

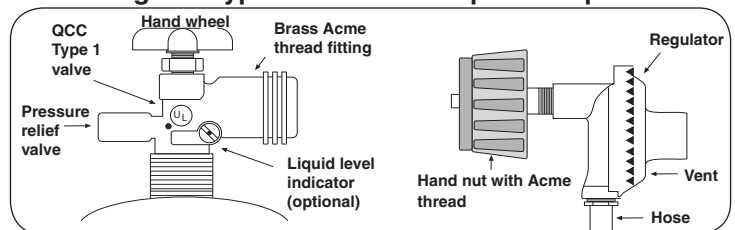

INSTALLATION REQUIREMENTS

Installation must be performed by a qualified professional service technician.

This unit is designed for outdoor use only. **DO NOT** use this unit inside a building, garage, or enclosed area. **DO NOT** use this unit in or on a recreational vehicle or boat.

The unit must have a minimum clearance of 18" from combustible materials/items in all directions.

OVERHEAD CONSTRUCTION AND EXHAUST HOOD REQUIREMENTS

A minimum 5 foot clearance is required between the cooking surface and the overhead construction.

When installed under combustible overhead construction, the area above the cooking surface of the unit **must** be covered with an exhaust hood. The exhaust hood provides the protection for the combustible overhead construction. See exhaust hood information below and Fig. 8-1.

Important: **DO NOT** use this appliance under **unprotected** combustible overhead construction.

When installed under overhead non-combustible construction, an exhaust hood is highly recommended; see exhaust hood information below and Fig. 8-1.

Exhaust Hood

When using an exhaust hood, the area above the cooking surface of the grill must be covered with a hood larger than the cooking area of the grill, and with a minimum of 1200 CFM (cubic feet per minute) for proper outdoor application.

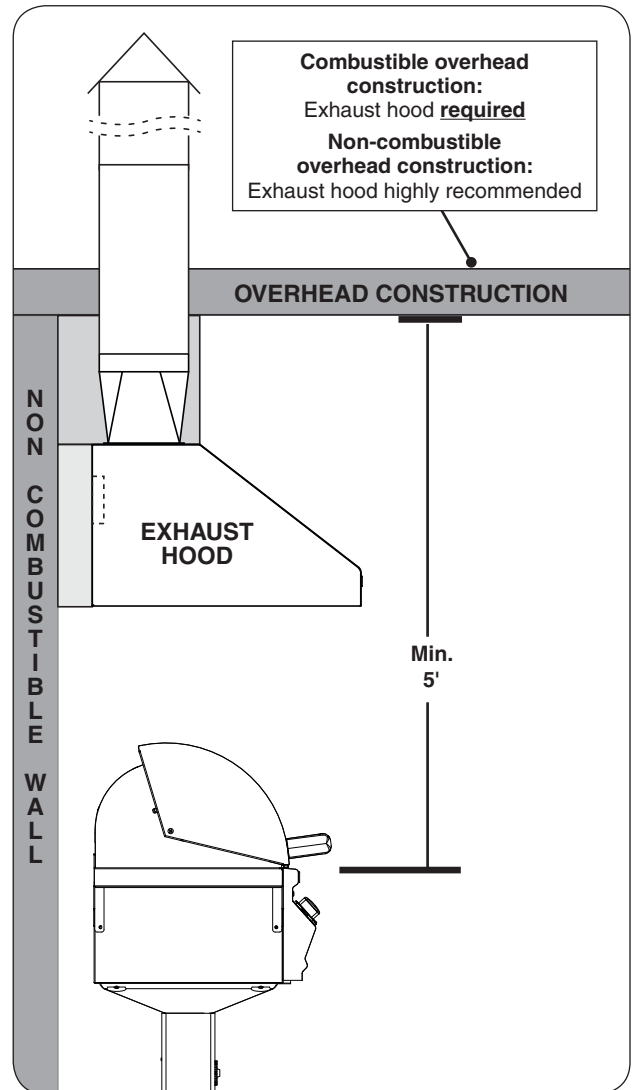

Fig. 8-1 Overhead requirements

INSTALLATION REQUIREMENTS (Cont.)

SIDE AND REAR WALL CLEARANCES

For the minimum clearances between the unit and any side or rear walls, your setup must fall within one (or more) of the following:

A. Clearance between unit and strictly non-combustible wall

(i.e. brick wall, see Fig. 9-1)

- The unit must have a minimum of 4" right, left, and rear clearance from any non-combustible wall.
(To allow for proper ventilation and prevent dangerous overheating.)

B. Clearance between unit and a protected combustible wall

(i.e. a non-combustible wall in front of a combustible wall to serve as a barrier. This can be accomplished by brick, or a metal stud finished with non-combustible substrate, see Fig. 9-2)

- The unit must have a minimum of 14" right, left, and rear clearance from the protected combustible wall.
(The 4" non-combustible material plus an additional 10" clearance between the unit and protected wall.)

C. Clearance between unit and combustible wall

- The unit must have a minimum of 18" right, left, and rear clearance from any combustible wall (see Fig. 9-3).

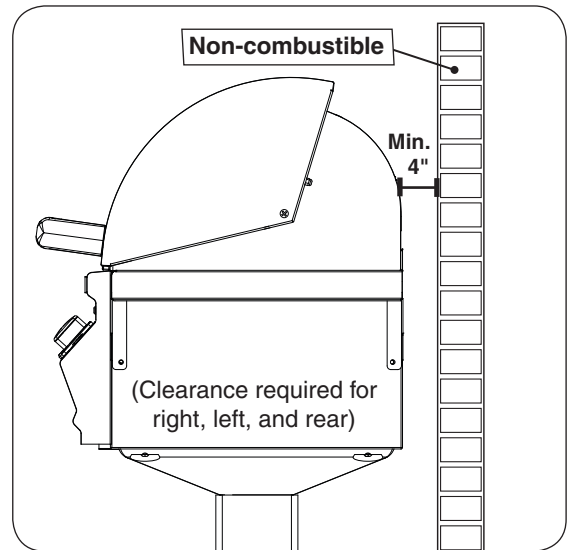

Fig. 9-1 Clearance 'A' Diagram

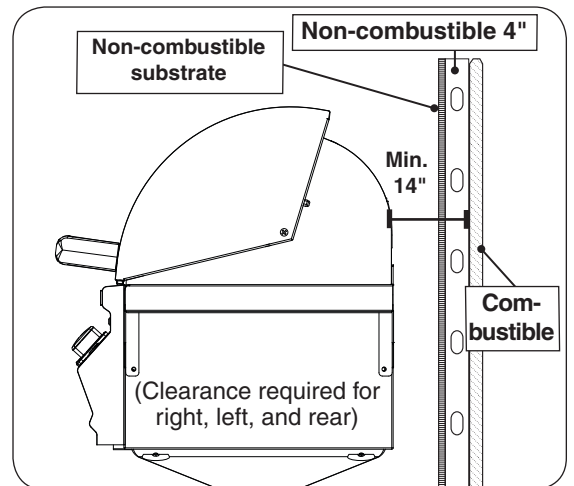

Fig. 9-2 Clearance 'B' Diagram

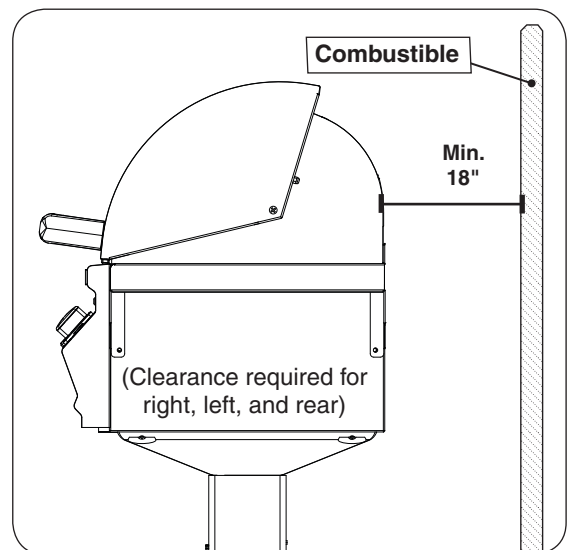

Fig. 9-3 Clearance 'B' Diagram

INSTALLATION REQUIREMENTS (Cont.)

The control panel **MUST** remain removable for servicing (see SERVICING AND CLEANING, Control Panel Removal section).

ENSURE PROPER COMBUSTION AIR AND COOLING AIRFLOW

Proper airflow (front-to-back, Fig. 10-1) **MUST** be maintained for the unit to perform as it was designed. If airflow is blocked, overheating and poor combustion will result. Do not block the 1" front air inlet along the bottom of the control panel.

CAUTION: Wind blowing into or across the rear oven lid vent (Fig. 10-2) can cause poor performance and/or dangerous overheating. Install the grill so that the prevailing wind blows toward the front of the grill (Fig. 10-3). **A wind deflector is available for purchase to assist in proper airflow during windy conditions**. See Table 1 for model numbers. Follow the instructions included with the wind deflector for installation.

GAS-SUPPLY PLUMBING REQUIREMENTS

For natural gas or a household propane system, rigid $\frac{1}{2}$ " or $\frac{3}{4}$ " black steel pipe or local code-approved pipe is required to conduct the gas supply to the unit. Contact your local gas supplier. Connect this pipe to the C.S.A.-approved quick connect hose (attached). Apply only joint compounds that are resistant to all gasses to all male pipe fittings except flare fittings. Make sure to tighten every joint securely.

Note: If $\frac{1}{2}$ " pipe is used with **natural gas**, it should be no longer than 20'.

Important: **A shut-off valve (not included) in the gas line is required.** It provides for safety when the unit is not in use and for convenient maintenance and repair. It must be installed within 6 feet of the unit. Use a pipe joint compound resistant to all gasses on all male fittings except flare fittings.

GAS SUPPLY AND MANIFOLD PRESSURES:

For **natural gas** - normal 7" water column (w.c.), minimum 5", maximum 10 $\frac{1}{2}$ ". For **propane gas** - normal 11" w.c., minimum 10", maximum 13".

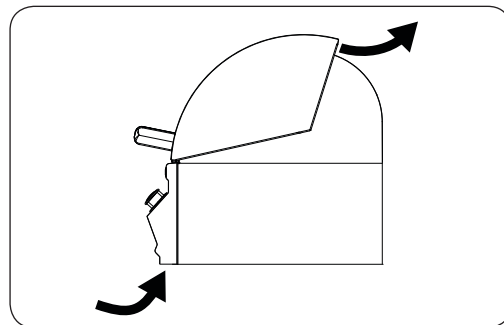

Fig. 10-1 Airflow diagram

INCORRECT



YOU MUST PROTECT REAR OVEN VENT FROM PREVAILING WIND

Fig. 10-2 Airflow direction - INCORRECT

CORRECT



PLACE GRILL SO PREVAILING WIND BLOWS TOWARD FRONT OF GRILL

Fig. 10-3 Airflow direction - CORRECT

MODEL SPECIFICATIONS

	C430s
Main burner quantity N/P orifice drill size	2 #43 / #54
Wind deflector model # (not included)	23728-18
Battery quantity Battery type	1 9-volt

Table 1 - Product Specifications

MODEL SPECIFICATIONS (cont.)

Height			Width		Depth	
Floor to top (with oven)		Floor to top of shelf (C)	Left to right		Front to back	
Open (A)	Closed (B)		Post base (D)	Shelves (E)	Post base (F)	Maximum outer (G)
57"	50"	37"	26"	51 1/2"	20 1/4"	24 3/4"

Table 2 - Post Patio Mount Grill Dimensions

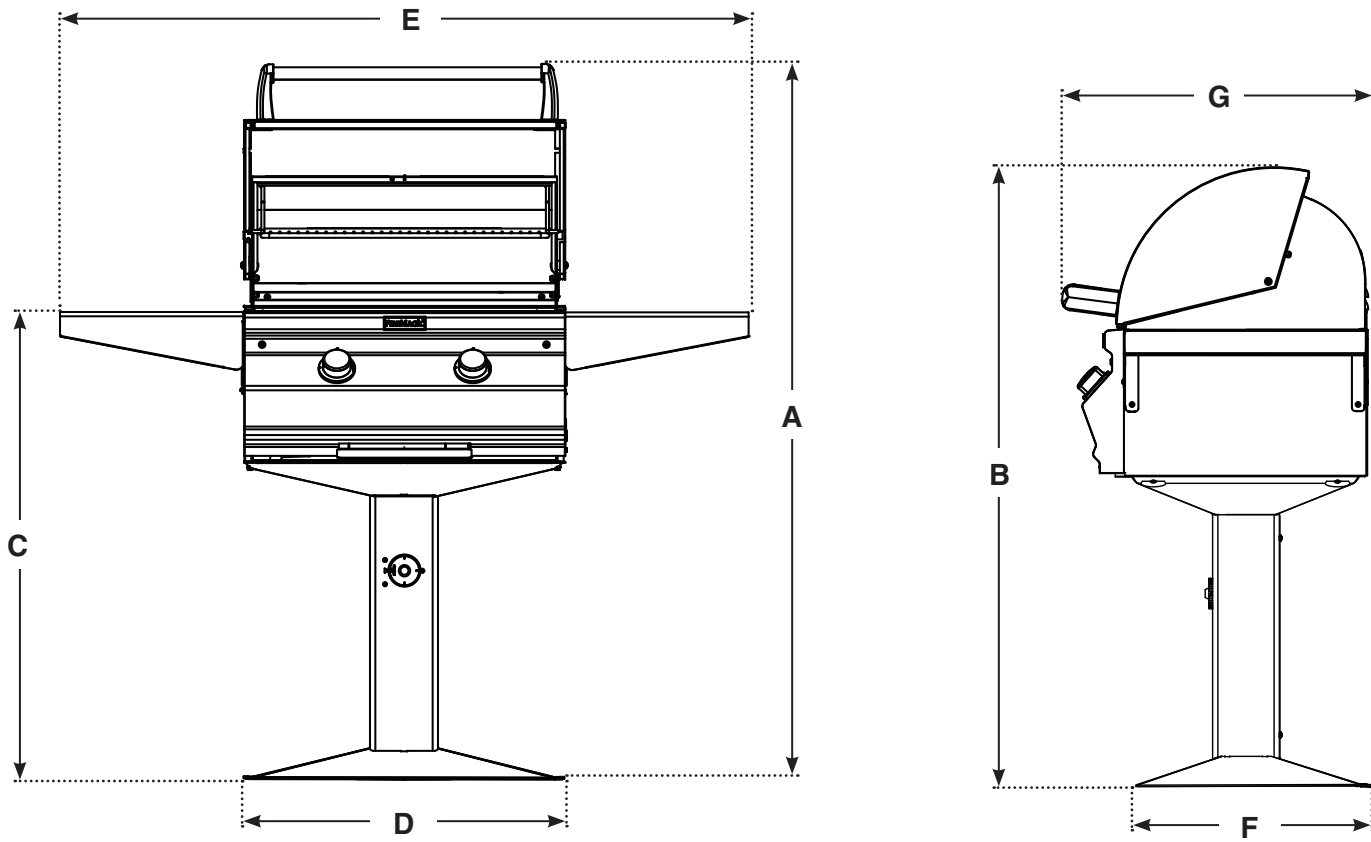

Fig. 12-1

MODEL SPECIFICATIONS (cont.)

Height*				Width		Depth	
Floor to top (with oven)		Floor to top of shelf (J)	Floor to bottom of extension below ground (K)	Left to right		Front to back	
Open (H)	Closed (I)			Post (L)	Shelves (M)	Post (N)	Maximum outer (O)
57"	50"	37"	18"	5 1/2"	51 1/2"	5 1/2"	24 3/4"

***Note:** Height dimensions are approximate from ground level once installed.

Table 3 - In-Ground Post Grill Dimensions

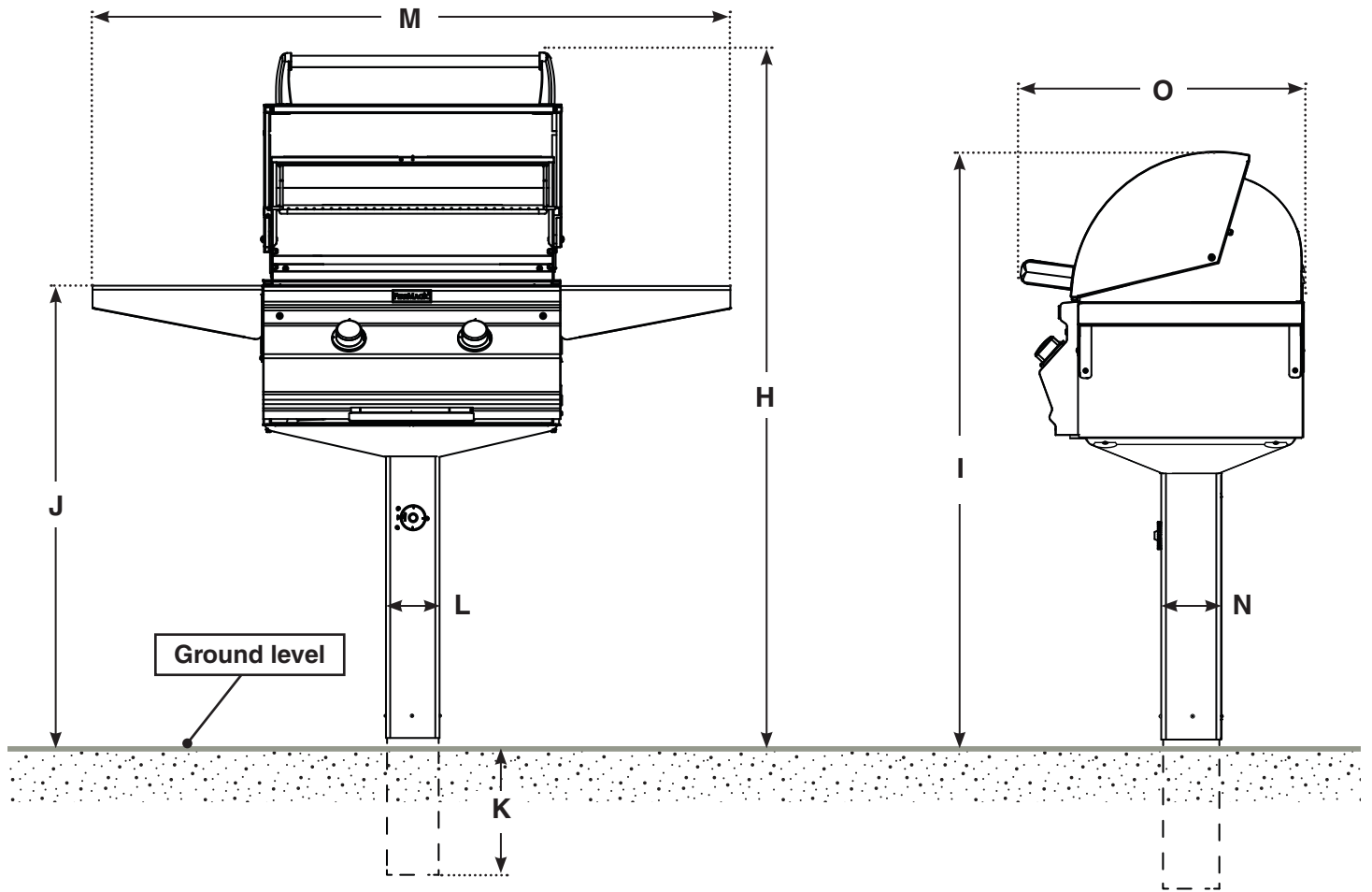
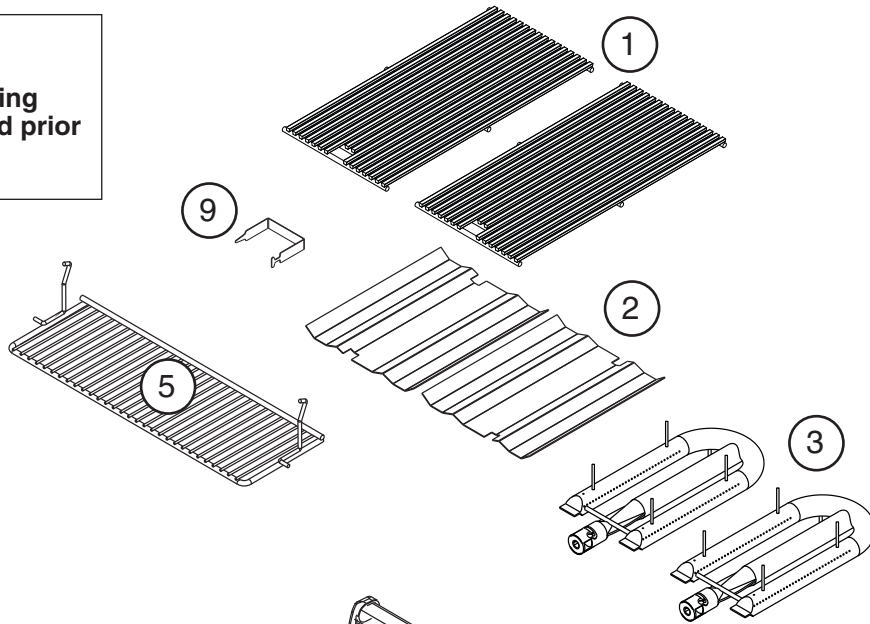

Fig. 13-1

REPLACEMENT PARTS LIST

IMPORTANT
Remove all packing material and discard prior to lighting.



To order replacement parts, contact your local Fire Magic® dealer.

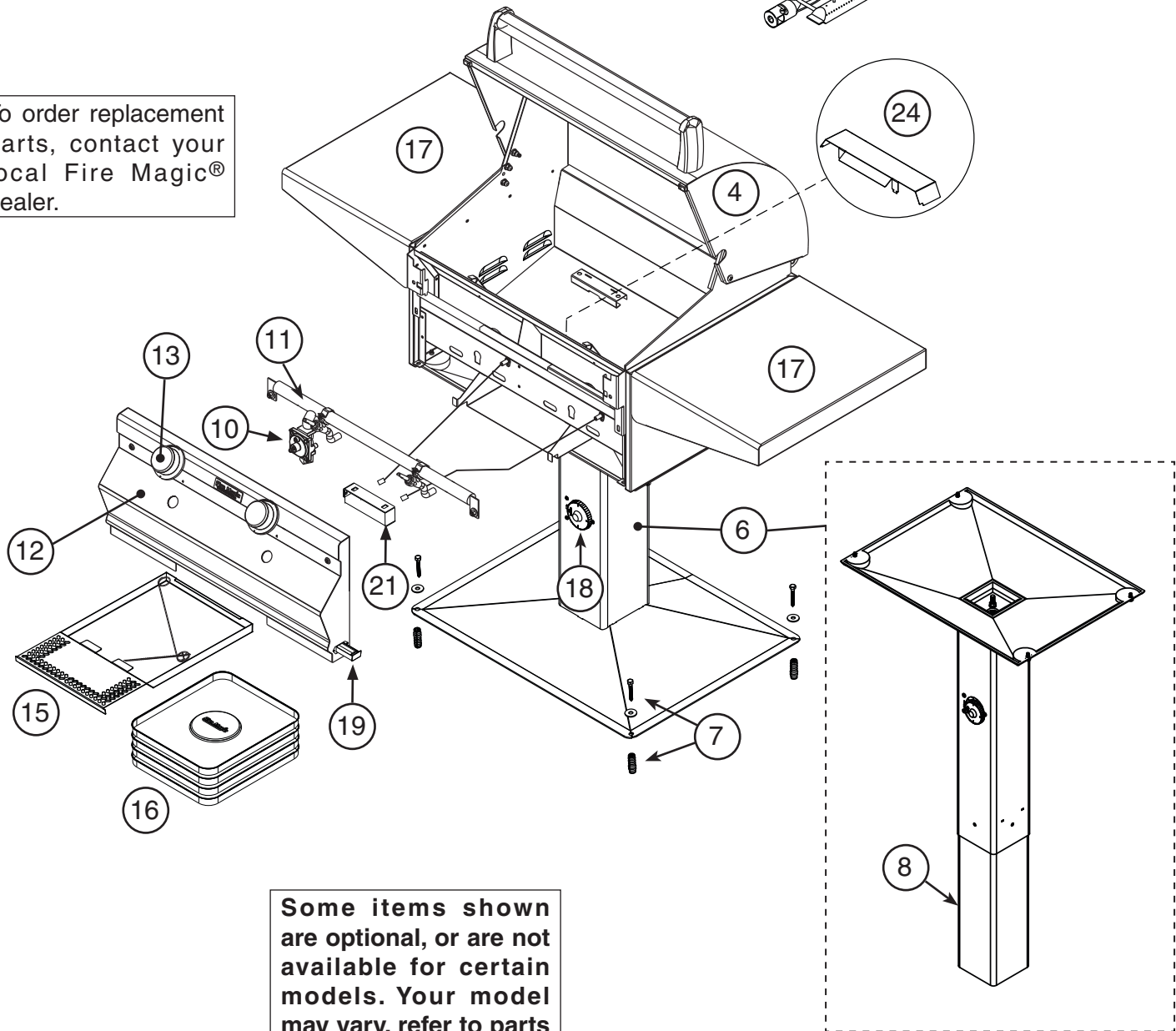

Some items shown are optional, or are not available for certain models. Your model may vary, refer to parts table.

REPLACEMENT PARTS LIST (cont.)

Item	Description	C430s	
		Part No.	Qty.
1.	Stainless cooking grid (set of 2)	3542-DS-2	1
2.	Flavor grid (set of 2)	3063-S-2	1
3.	Main burner	3042-60	2
4.	Oven lid	23729-57	1
5.	Warming rack*	3672S-M	1
6.	Patio mount post base w/ hardware †	24330-31	1
or	In-ground post base w/ hardware †	24330-32	1
7.	Patio mount hardware kit (if applicable)	24330-25	1
8.	In-ground post extension only †	24330-33	1
9.	Grid lifter	3519	1
10.	Convertible regulator	PR-4	1
11.	Valve manifold	24130-28	1
12.	Control panel assembly	24330-36	1
13.	Control knob	3015	2
14.	Oven hood thermometer ‡	23305	1
15.	Drip tray	3085	1
16.	Drip tray liner (set of 4)	3557	1
17.	Rigid shelf	24-C-01	2
18.	Timer valve (1 hour)	3092A	1
19.	Igniter battery holder assy (9v)	24180-38	1
20.	Electrode & collector box assy ‡	3199-45	2
21.	Igniter module	3199-51	1
22.	Natural gas orifice(s) ‡	3001-43-2	1
23.	Propane gas orifice(s) ‡	3001-54-2	1
24.	Air baffle	24194-40	1

* If equipped

† For replacement only (not conversion)

‡ Not shown

PATIO MOUNT INSTALLATION

It is not required to remove the control panel or knobs to install this unit.

DO NOT lift the unit from the control panel when installing.

PREPARE FOR INSTALLATION

Consult a qualified professional installer.

The flex connector can be routed out the back of the post, under the post base, or inside the post.

To gain access to the inside of the post, unscrew and carefully open the access plate on the rear of the post using a medium Phillips-head screwdriver. Retain the screws.

ROUTE FLEX CONNECTOR

The gas supply line will need to be run to the post install location as appropriate for the desired setup.

To route flex connector through rear of post:

1. Remove a knock-out disk at the bottom of the access plate with a large flathead screwdriver. (Insert the screwdriver into the notch provided in the center of the knock-out.)
2. Remove the plastic grommet (attached to the flex connector) and insert it into the newly created opening. Then route the flex connector through the opening. See Fig. 16-1 and 16-2.

To route flex connector beneath post base:

Route the flex connector through the hole found beneath the center of the post base (see Fig. 16-3).

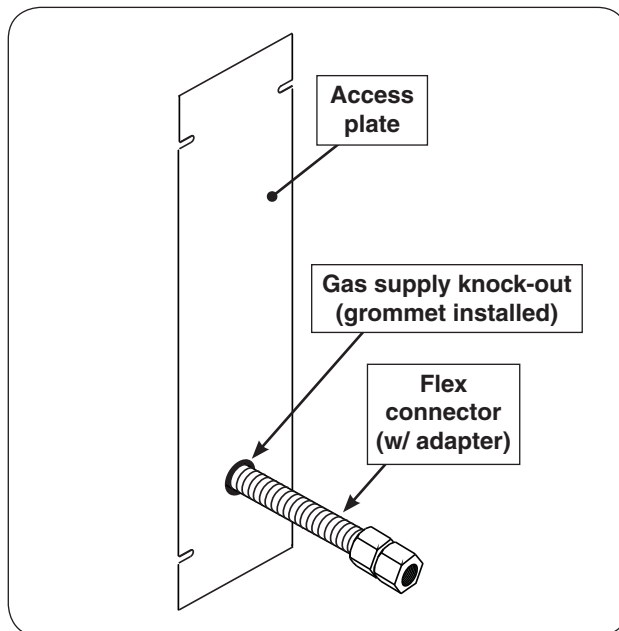

Fig. 16-1 Access plate view & install orientation

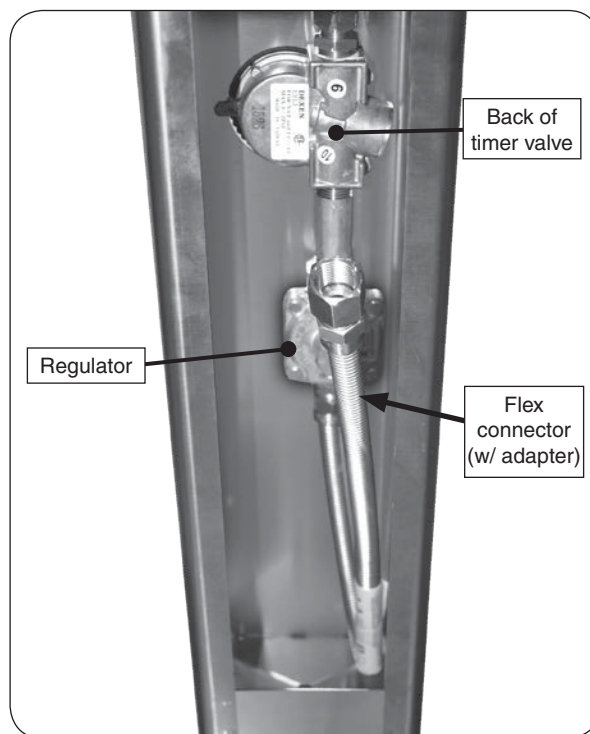

Fig. 16-2 Post interior detail

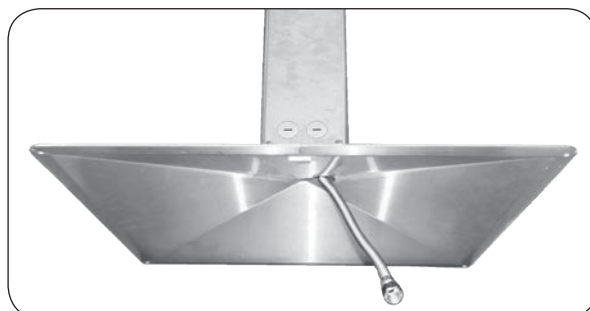

Fig. 16-3 Post base option

CONNECT THE GAS SUPPLY

For household propane or natural gas units:

1. Route the flex connector to the gas stub.
2. **Turn OFF the gas supply at the source.**
3. A shut-off valve is required within 6 feet of the unit.

If shut-off valve is connected to end of gas supply stub:

- Connect the flex connector to the shut-off valve (see Fig. 17-2). Tighten securely.

If shut-off valve is installed in-line:

- Install the supplied flare adapter to the gas supply using a pipe joint compound resistant to all gasses (see Fig. 17-2). Tighten securely.
- Connect the flex connector to the flare adapter (see Fig. 17-2). Tighten securely.

For propane cylinders:

For connecting a propane unit to a portable propane tank, read the safety warnings and follow the instructions in the section SAFE USE AND MAINTENANCE OF PROPANE GAS CYLINDERS.

Important: An appropriate adapter will be required to connect the existing flex connector to an L.P. regulator/hose assembly.

LEAK TEST

Turn all burner control knobs to the **OFF** position. Turn the gas supply on. Then carefully check *all* gas connections for leaks with a brush and half-soap/half-water solution before lighting. **NEVER USE A MATCH OR OPEN FLAME TO TEST FOR LEAKS.**

RE-SECURE ACCESS PLATE

Carefully replace the access plate using the four screws, ensuring all interior components are properly oriented inside of the grill. Ensure the power supply cord (and flex connector if applicable) coming out of the rear of the post are properly situated and the plastic bushing/grommet pieces are secure in place.

SECURING THE PATIO MOUNT GRILL

Important: **BEFORE USE**, the patio mount base must be securely fastened to a stable, level surface to ensure the grill remains fixed and upright at all times.

Locate the patio mount base in the planned grill location and mark the 4 holes. Drill the marked holes to a 1/2" diameter x 1 1/2" depth. Insert the lag shields (see PARTS LIST) into the holes, being sure that they are flush with the ground.

Align the holes on the patio mount base over the lag shields in the ground. Secure the base with the lag screws (see PARTS LIST) using a 7/16" nut driver.

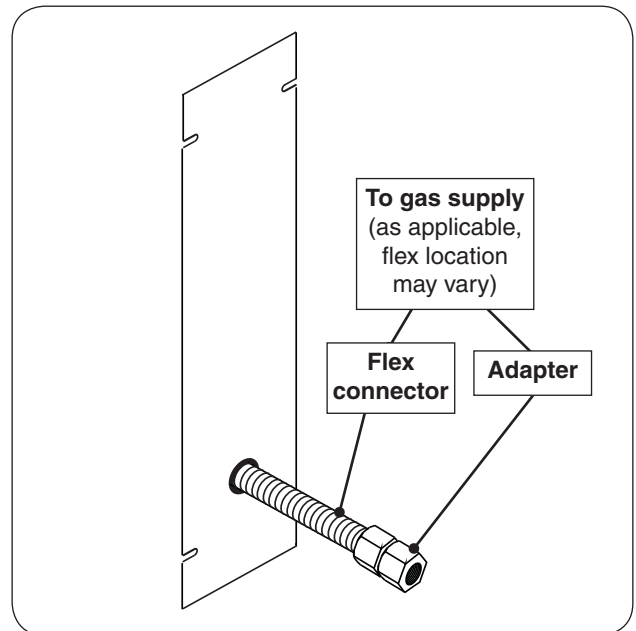

Fig. 17-1 Connect gas and secure plate

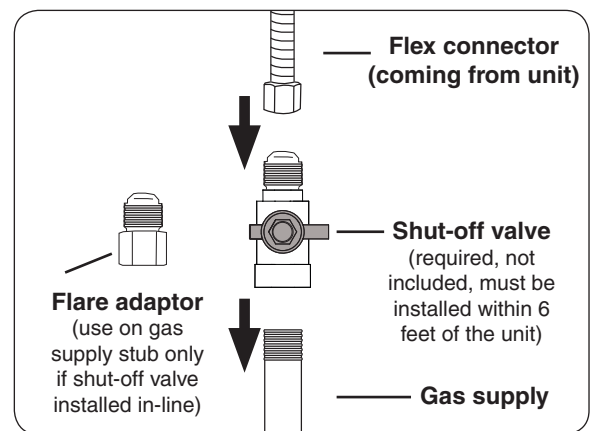

Fig. 17-2 Connecting to a gas line

IN-GROUND POST INSTALLATION

PREPARE FOR INSTALLATION

Consult a qualified professional installer / licensed contractor.

The in-ground post is designed primarily for installation with a permanent underground gas supply.

To gain access to the inside of the post, unscrew and carefully open the access plate on the rear of the post using a medium Phillips-head screwdriver. Retain the screws.

ROUTE GAS SUPPLY (UNDERGROUND METHOD)

Note: This section addresses an underground gas supply setup. To connect through the rear of the post, reference the ROUTE FLEX CONNECTOR section of PATIO-MOUNT INSTALLATION, and do not perform the steps until after: attaching the extension post, and installing the post / pouring the concrete.

1. After running the underground gas supply line to the planned grill location, dig a hole for the post and extension approximately 18" deep and 10-12" in diameter.

Note: Run the gas supply line up from the bottom of the hole (a little off center) so that it reaches to approximately 4" above ground level.

Note: The actual depth of the hole should be such that the cooking surface is 34-35" above ground level.

2. Verify that the gas supply line fits through the gas line clearance hole in the bottom of the post (see Fig. 18-2). The clearance hole is the larger of the two holes in the bottom of the post and is off center.
3. Verify that the flex connector coming from the inside of the post will connect properly with the gas supply line.

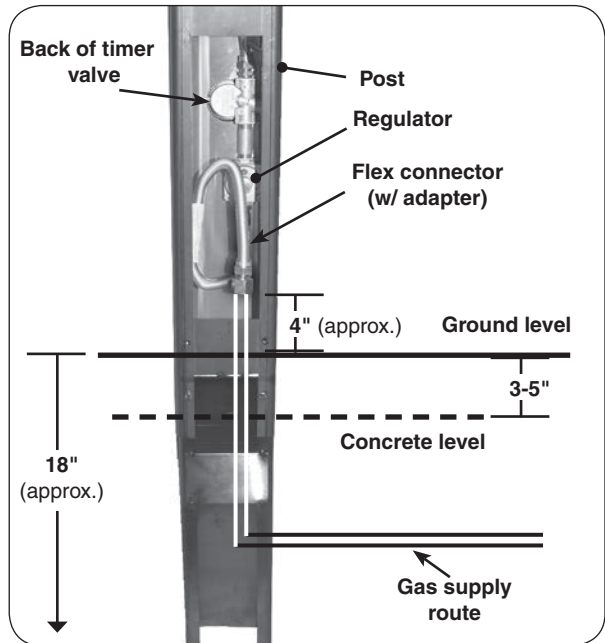

Fig. 18-1 In-ground install orientation

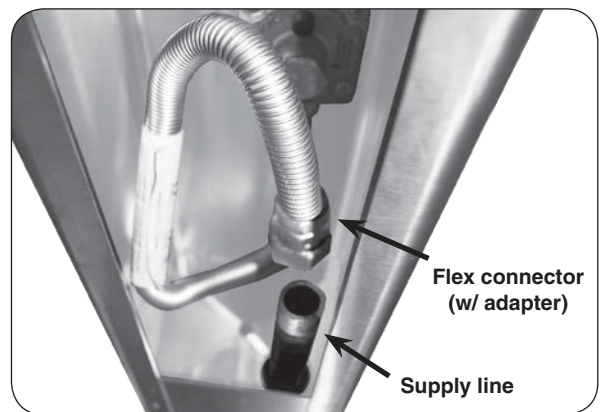

Fig. 18-2 Post interior detail

IN-GROUND POST INSTALLATION (cont.)

ATTACH POST EXTENSION

1. Attach the extension to the bottom of the grill post so that the open portion is toward the back of the grill and the five holes in the extension line up with the five (5) weld-nuts in the post (see Fig. 19-1).
2. From outside the joined post and extension, insert one of the $\frac{1}{4}$ X 20"-5/8 bolts (supplied) into each of the five (5) bolt holes and tighten each using a $\frac{7}{16}$ " socket driver or wrench (see Fig. 19-2).

Note: There is one hole on each side of the post, except the back which has two holes located on either side of the extension opening.

PLACE POST IN-GROUND & POUR CONCRETE

1. Prepare the concrete to be used for the install.
2. Carefully orient the post over the gas supply line and into the installation hole.

Important: Verify that the gas supply line is running up through the post hole, just off center. It must extend high enough to reach the grill gas connection and remain safely above the level of the concrete when poured.

3. Remove the post, then cover the end of the gas supply line with a plastic bag and/or masking tape to avoid getting concrete or other debris in the supply line.
4. Pour the concrete into the hole 3-5" below ground level taking care to protect the gas supply line.
5. While the concrete is still wet, carefully lower the extended grill post into the hole so that the gas supply line slides through the clearance hole in the bottom of the post.
6. Orient the grill per plan, then level the grill and support it so that it remains in position while the concrete dries.

ROUTE FLEX CONNECTOR (ABOVE GROUND METHOD ONLY)

Note: This section addresses an above ground gas supply setup. If connecting underground, skip this section and continue with installation.

The gas supply line will need to be run to the post install location as appropriate for the desired setup.

To route flex connector through rear of post:

1. Remove the knock-out disk at the bottom of the access plate with a large flathead screwdriver. (Insert the screwdriver into the notch provided in the center of the knock-out.)
2. Remove the plastic grommet (attached to the flex connector) and insert it into the newly created opening. Then route the flex connector through the opening. See Fig. 19-4.

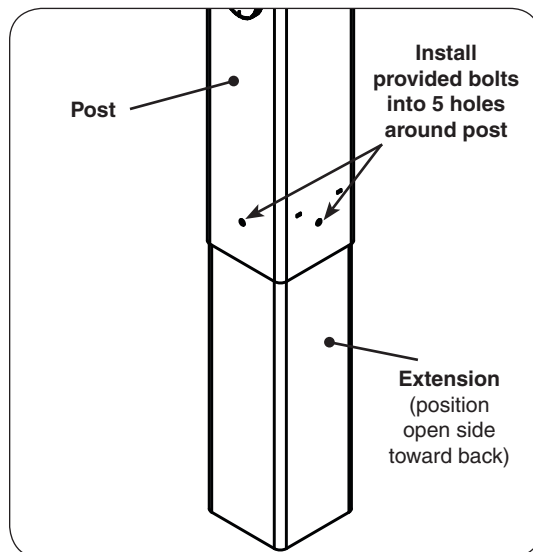

Fig. 19-1 Install extension to post

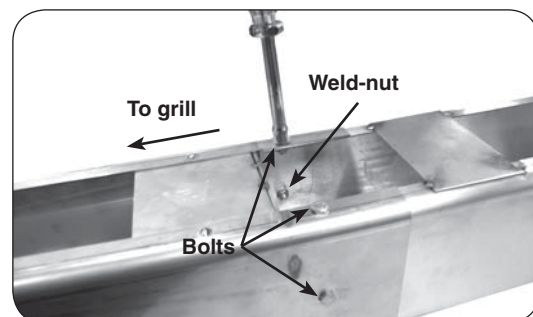

Fig. 19-2 Fasten extension to post

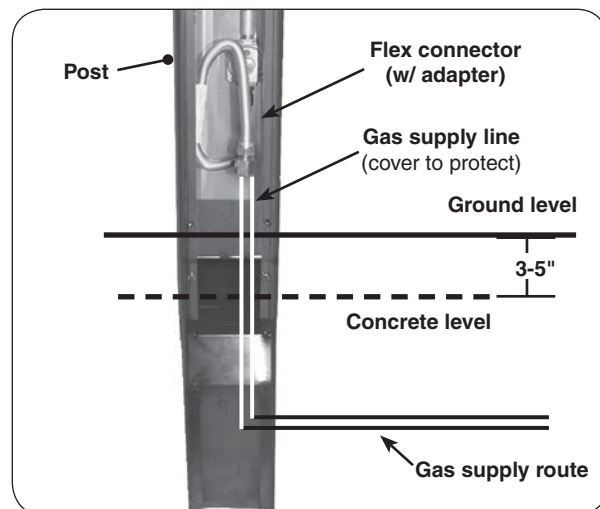

Fig. 19-3 Pour concrete & install post

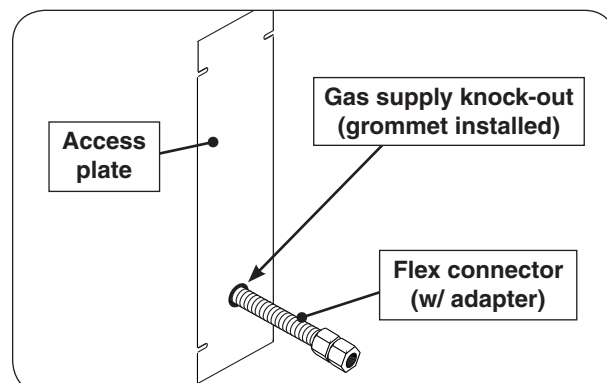

Fig. 19-4 Access plate view & install orientation

IN-GROUND POST INSTALLATION (cont.)

CONNECT THE GAS SUPPLY

For household propane or natural gas units:

1. Route the flex connector to the gas stub.
2. Turn OFF the gas supply at the source.
3. A shut-off valve is required within 6 feet of the unit.

If shut-off valve is connected to end of gas supply stub:

- Connect the flex connector to the shut-off valve (see Fig. 20-1). Tighten securely.

If shut-off valve is installed in-line:

- Install the supplied flare adapter to the gas supply using a pipe joint compound resistant to all gasses (see Fig. 20-1). Tighten securely.
- Connect the flex connector to the flare adapter (see Fig. 20-1). Tighten securely.

For propane cylinders:

For connecting a propane unit to a portable propane tank, read the safety warnings and follow the instructions in the section SAFE USE AND MAINTENANCE OF PROPANE GAS CYLINDERS.

Important: An appropriate adapter will be required to connect the existing flex connector to an L.P. regulator/hose assembly.

LEAK TEST

Turn all burner control knobs to the **OFF** position. Turn the gas supply on. Then carefully check *all* gas connections for leaks with a brush and half-soap/half-water solution before lighting. NEVER USE A MATCH OR OPEN FLAME TO TEST FOR LEAKS.

RE-SECURE ACCESS PLATE

Carefully replace the access plate using the four screws, ensuring all interior components are properly oriented inside of the grill. If applicable, ensure the flex connector coming out of the rear of the post is properly situated and the grommet piece is secure in place.

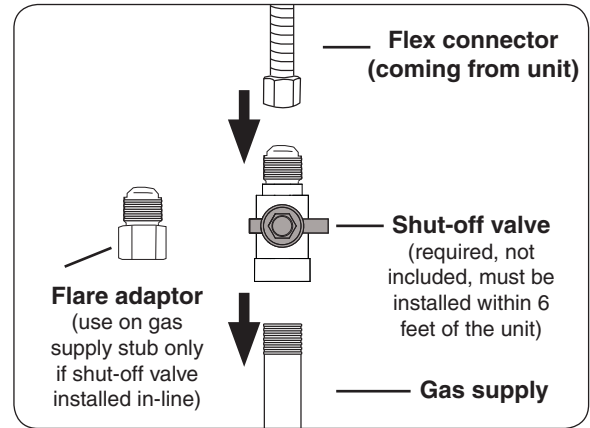

Fig. 20-1 Connecting to a gas line

INSTALL THE FLAVOR GRIDS

Place the flavor grids directly onto the studs on the burners. See Fig. 21-1. The flavor grids allow heat from the burners to be evenly distributed throughout the cooking area.

INSTALL THE COOKING GRIDS

Note: Wear heat-resistant gloves if necessary.

Note: Do not leave the lifter on any hot surfaces.

1. With the prongs facing downward, insert the notched-end of the lifter between two grid rods, then rotate, as shown in Fig. 21-2, A & B.

Note: To balance, insert the notched-end of the lifter in the middle front half of the cooking grid.

2. Insert the rear pointed-end of the lifter between the same two rods (Fig. 21-2, B) and carefully lift the cooking grid and place onto the front and rear grid rests of the grill (see Fig. 21-3). Repeat for all other cooking grids.

INSTALL THE DRIP TRAY

Your grill includes a pack of four drip tray liners. Place a liner into the drip tray as shown in Fig. 21-4, and fully insert the drip tray into the bottom front of the control panel.

Note: The liner must fit under the rear lip and two front tabs found on the drip tray.

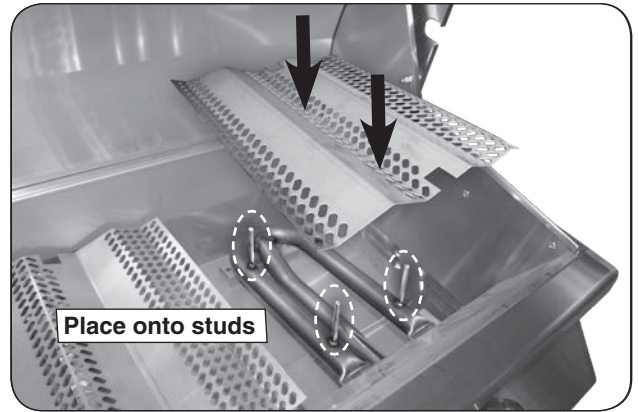

Fig. 21-1 Install flavor grids

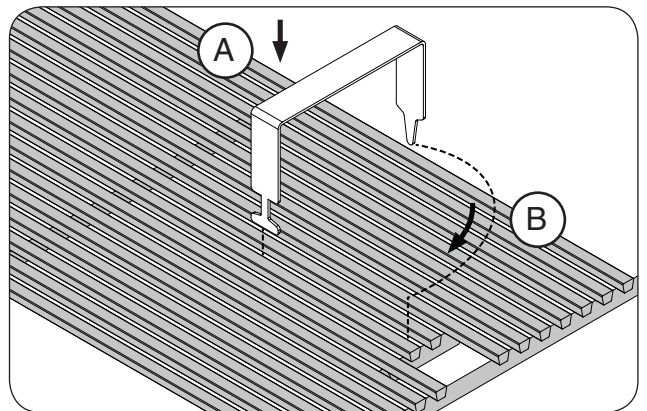

Fig. 21-2 Install cooking grids



Fig. 21-3 Install cooking grids

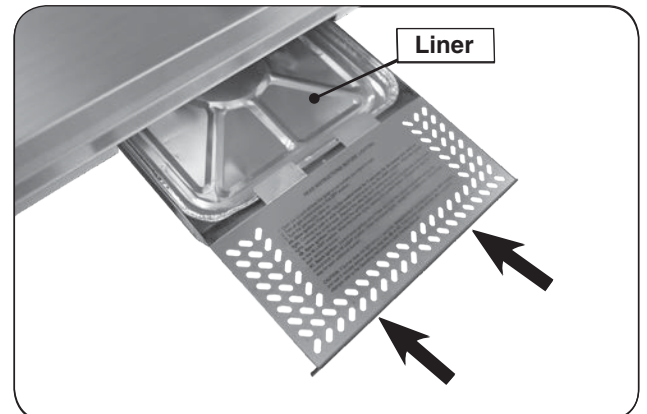

Fig. 21-4 Install drip tray

INSTALL THE WARMING RACK

The warming rack (Fig. 22-1) is packed separately. To install the warming rack, carefully insert the rack hangers into the two holes in the back of the inner oven hood, then lower the front of the rack to a level position.

INSTALL THE RIGID SHELVES

This grill comes with two (2) rigid shelves that must be attached. These can be attached using the four support screws provided and a Phillips-head screw driver.

Important: Take caution to not cross-thread when tightening the screws.

1. Hold the shelf inverted so that one of the corner holes in the shelf lines up with the appropriate upper screw hole in the grill.
2. Insert the screw, but do not tighten all the way so that the shelf can be easily rotated around the first screw.
3. Line up the second corner hole in the shelf with the remaining upper screw hole in the grill. Insert a screw and tighten.

Note: You may lift the edge of the shelf upward to gain better access during much of the tightening of this screw.

4. Finally, insert the bottom screws on the left and right side of the shelf and securely tighten all screws.

To detach, reverse the process above.

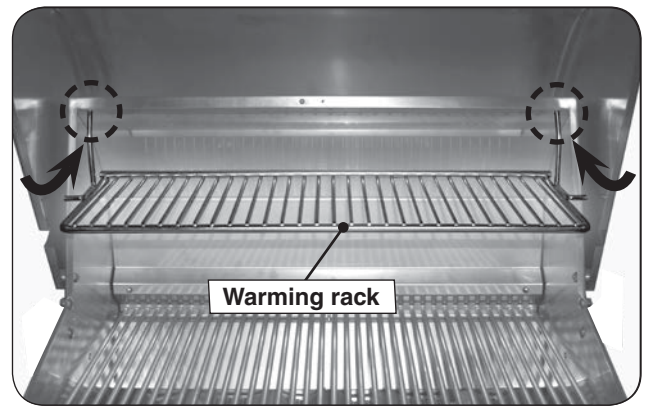

Fig. 22-1 Install warming rack

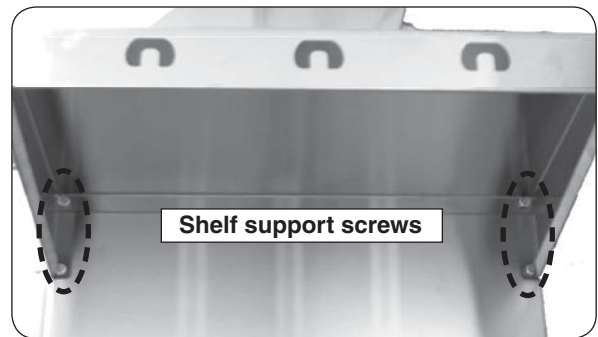

Fig. 22-2 View from under right shelf

IDENTIFICATION OF GRILL CONTROLS

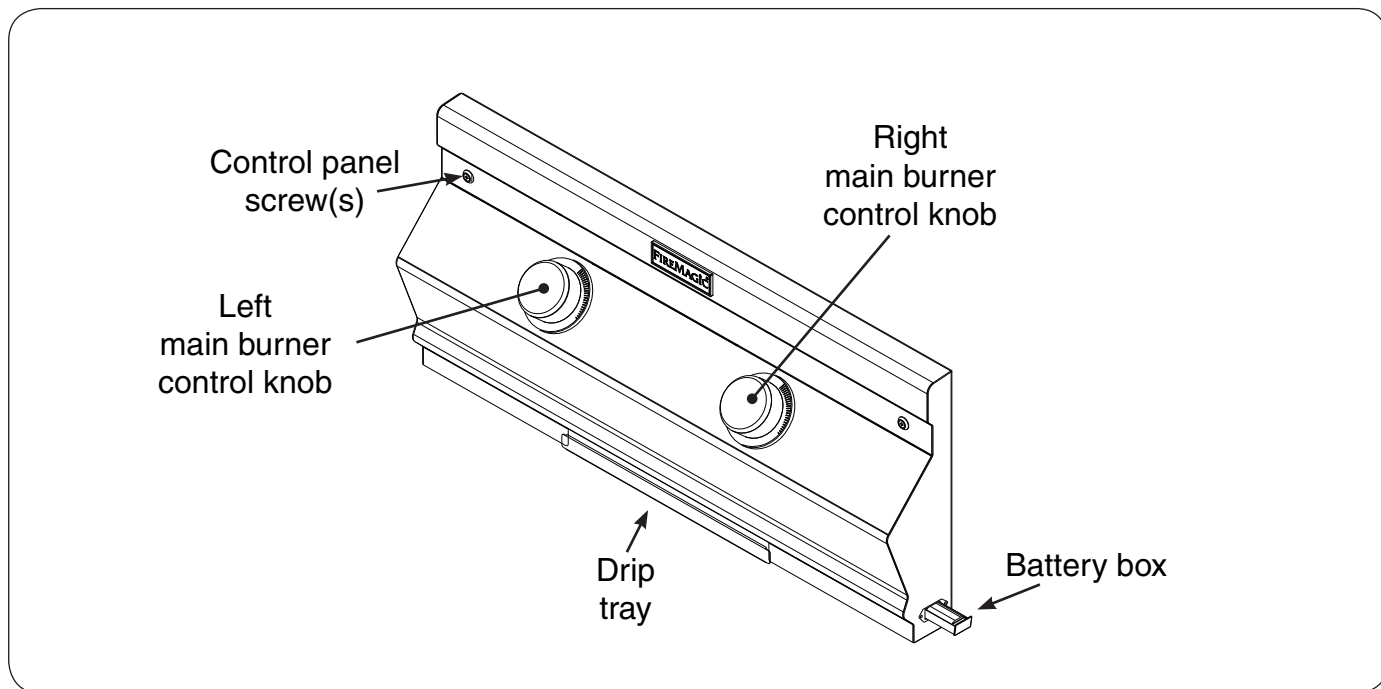

Fig. 23-1 C430s controls

USING THE GRILL

BEFORE INITIAL USE

Ensure that:

- the grill has been properly installed and leak tested by a qualified professional service technician and as instructed in this manual.
- you have read and understand all of the information in this manual.

BEFORE EACH USE

Ensure that:

- you smell around the appliance area for gas. If you smell gas (and all control knobs are in the **OFF** position), immediately shut off the gas supply and contact a qualified professional service technician or the gas supplier for inspection.
- the vent openings and surrounding area of the unit are clear and free at all times.
- the cooking area and drip tray are clean, and the drip tray is properly installed.
- you inspect all piping and hoses for damage, cuts, wear, and tear. Replace any damaged components prior to use.

OPERATION

- **The grill becomes HOT during use. NEVER touch any part of the cooking area or surrounding hot surfaces with bare hands. Use long-handled insulated BBQ tools and wear an insulated glove / oven mitt.**
- **Always keep your face and body as far from the grill as possible during use. Avoid wearing loose-fitting clothing as they could ignite.**
- **NEVER use charcoal or any other solid-fuel in the grill.**
- **NEVER leave the grill unattended during use.**
- **NEVER cover more than 75% of the cooking or grill surface with griddles or pans to prevent overheating.**

After reading and understanding all bullets above, follow these steps to light and use your grill:

1. Light the grill per the LIGHTING INSTRUCTIONS section.
2. Turn the control knobs to the HI-LIGHT position, close the hood, and allow the grill to preheat for 15 minutes or until desired cooking temperature is reached.
3. Place the food on the grill and cook as desired. Monitor the flames and temperature, and adjust the heat setting if necessary. Ensure the timer on the unit remains on during cooking - see LIGHTING INSTRUCTIONS section.
4. See the sections below and the following pages for all other information regarding use.

WIND CONSIDERATIONS

Proper airflow (front-to-back, Fig. 24-1) **MUST** be maintained for the grill to perform as it was designed. See the INSTALLATION REQUIREMENTS section for details.

When using the grill in windy conditions, the wind can disrupt the airflow and cause overheating. To prevent overheating during windy conditions, do not leave the hood closed with the burners on high for more than 15 minutes.

AFTER EACH USE

1. Brush the cooking grids to remove all residue.
2. Operate on high with hood closed for 10-15 minutes to burn off all grease.
3. Cover the grill once it has completely cooled.

Note: For additional cleaning, refer to the SERVICING AND CLEANING section.

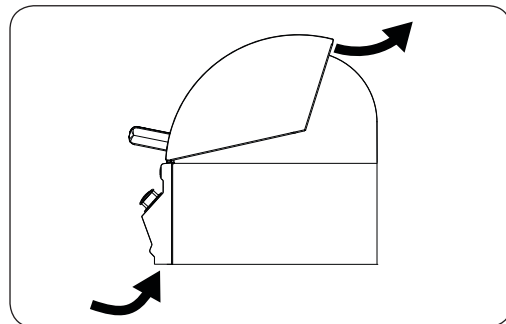

Fig. 24-1 Airflow diagram

LIGHTING (IGNITION) INSTRUCTIONS

Read all instructions before lighting, and follow these instructions each time you light the unit.

ELECTRONIC LIGHTING

Note: Electronic lighting requires an installed 9-volt battery with a good charge.

1. Open lid(s) or remove cover(s) from burner(s) to be lit.
2. Turn all gas control knob(s) to their **OFF** position(s).
3. Turn on the gas at its source.

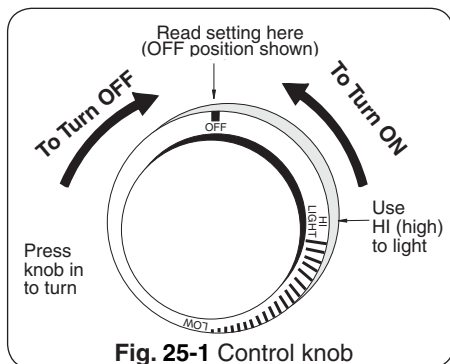

Note: DO NOT turn on more than one valve at a time for either electronic or manual lighting.

4. Set timer control knob to the desired cooking time.
5. Depress the desired control knob **for 5 seconds**, then, while pressing turn it counterclockwise to the **HI LIGHT** position. Once the burner lights, release the knob.

CAUTION: If a burner does not light within five (5) seconds of turning on the control knob, depress the knob and turn it to the **OFF** position. **WAIT FIVE (5) MINUTES** before repeating step 4. If you smell gas, follow the instructions on the cover of this manual. If the burners still do not light after several attempts, refer to the instructions for manual lighting.

6. Repeat step 5 for each additional burner to be lit.

SETTING THE TIMER

To use, set the dial (turn clockwise) to the desired time to shut off. The dial is marked in 3 twenty minute increments (any position in between is an estimate of that set time). The timer dial will auto rotate (counter-clockwise) and will shut off the gas supply when the dial reaches OFF (i.e. the time is completed).

Important: When using the timer for periods of less than twenty minutes, you must first set the dial to twenty minutes (to activate), then return (counter-clockwise) to the desired amount of time. This will ensure proper timer operation. See Fig. 25-4.

MANUAL LIGHTING

CAUTION: Always wait five (5) minutes for gas to clear after any unsuccessful lighting attempt.

1. Follow steps 1 through 4 (left).
2. Insert either a burning long-barrel butane lighter, a burning long-stem match, or a burning match held by a wire extension holder through the cooking grid opening to the top of the burner (Fig. 25-2).
3. While holding the match or lighter flame at the top of the burner, depress the control knob and while pressing turn it counterclockwise to the **HI LIGHT** position. Remove the lighter or match when the burner lights, and release the control knob.
4. If the burner does not light within five (5) seconds of turning the control knob, **immediately depress the knob and turn the valve to OFF**. **WAIT FIVE (5) MINUTES** before repeating steps 2 through 4 of the **MANUAL LIGHTING** instructions.

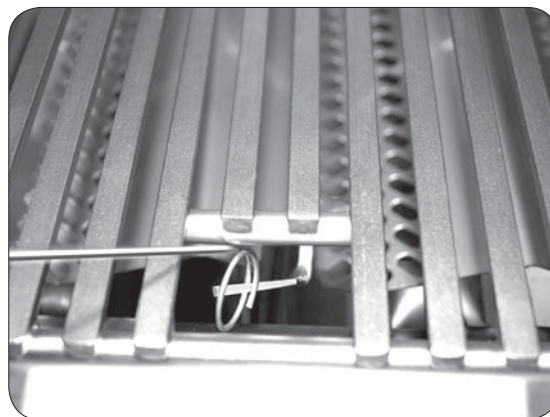

Fig. 25-2 - Manual lighting

SHUTTING OFF THE UNIT

To shut off the unit, depress each valve control knob and while pressing turn it clockwise to the **OFF** position.

Always close the valve from the gas supply after each use of the unit.

Fig. 25-4

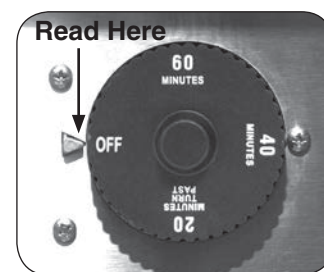

Timer knob in OFF position

ALLUMAGE DES INSTRUCTIONS (D'ALLUMAGE)

Lisez toutes les instructions avant l'allumage, et suivez ces instructions chaque fois vous lumière le unité.

ÉCLAIRAGE ÉLECTRONIQUE

Note: L'éclairage électronique exige une batterie installée de 9 volts avec une bonne charge.

1. Ouvrez les couvercles ou enlevez les couvertures des brûleurs pour être Lit.
2. Tournez tous les boutons de commande de gaz à leurs positions de repos.
3. Allumez le gaz à sa source.

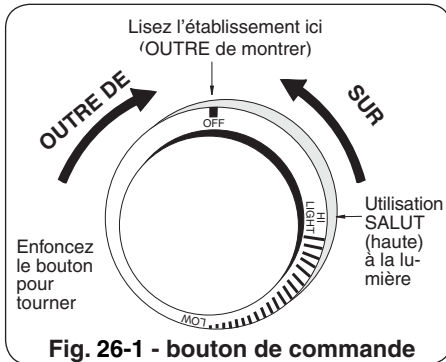

Note: N'ouvrez pas plus d'une valve à la fois pour l'éclairage électronique ou manuel.

4. Placez le bouton de commande de temporisateur au temps de cuisson.
5. Diminuez le bouton de commande désiré pendant 5 secondes, puis, et tout en pressant le tour il dans le sens contraire des aiguilles d'une montre dans la position LÉGÈRE de HI. Une fois que le brûleur s'allume, libérez le bouton.

ATTENTION : Si un brûleur ne s'allume pas dans cinq (5) secondes d'allumer le bouton de commande, enfoncez le bouton et tournez-le à la position de repos. ATTENDEZ CINQ (5) MINUTES avant de répéter l'étape 4. Si vous sentez le gaz, suivez les instructions sur la couverture de ce manuel. Si les brûleurs ne s'allument toujours pas après que plusieurs tentatives, se rapportent aux instructions pour l'éclairage manuel.

6. Répétez l'étape 5 pour que chaque brûleur additionnel soit Lit.

ÉTABLISSEMENT DU TEMPORISATEUR

Pour l'utiliser, placez le sélecteur (tourner dans le sens horaire) à l'heure souhaitée pour couper. Le cadran est marqué en 3 tranches d'une minute vingt (Toute position entre les deux est une estimation du fait que le temps). Le cadran de la minuterie rotation automatique (sens anti-horaire) et coupera l'alimentation en gaz lorsque la molette atteint OFF (le temps est terminé).

Important: Lorsque vous utilisez la minuterie pour des périodes de moins de vingt minutes, vous devez d'abord régler le cadran à vingt minutes (pour activer), puis retour (sens anti-horaire) à la quantité désirée de temps. Cela permettra d'assurer le bon fonctionnement de la minuterie. Voir Fig. 26- 4.

ÉCLAIRAGE MANUEL

ATTENTION: Attendez toujours cinq (5) minutes le gaz pour se dégager après que n'importe quelle tentative non réussie d'éclairage.

1. Suivez les étapes 1 à 4 (à gauche).
2. Insérez un allumeur brûlant de butane de long-baril, une allumette brûlante de long-tige, ou une allumette brûlante tenue par un support de prolongation de fil par la grille à cuire s'ouvrant au dessus du brûleur (fig. 26-2).
3. Tout en maintenant le match ou flamme du briquet au dessus du brûleur, appuyez sur le bouton de commande et en appuyant son tour dans le sens antihoraire à la position HI LIGHT. Enlevez l'allumeur ou assortissez quand le brûleur s'allume, et libérez le bouton de commande.
4. Si le brûleur ne se allume pas dans les cinq (5) secondes de tourner le bouton de commande, enfoncez immédiatement le bouton et tournez la valve à AU LOIN. ATTENDEZ CINQ (5) MINUTES avant de répéter les étapes 2 à 4 des instructions manuelles d'éclairage.

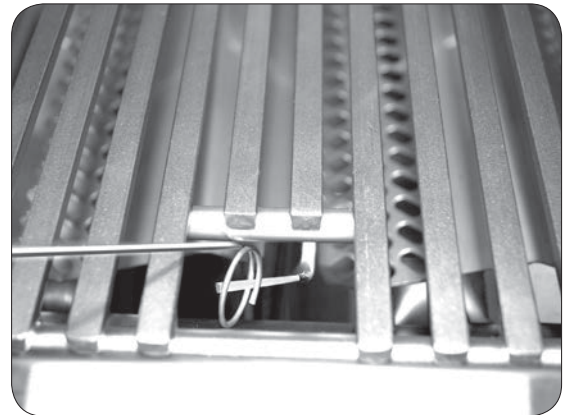

Fig. 26-2 - Éclairage manuel

ARRÊT DU UNITÉ

Pour couper le unité, diminuez chaque bouton de commande de valve et tout en pressant tour il dans le sens des aiguilles d'une montre à la position de repos.

Fermez toujours la valve de la fourniture de gaz après chaque utilisation du unité.

Fig. 26-4

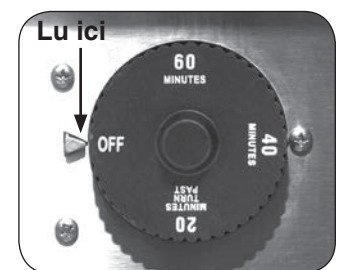

Bouton de temporisateur AU LOIN (temporisateur de 3 heures montré)

SERVICING AND CLEANING

APPLIANCE MUST BE COMPLETELY COOL WHEN CLEANING. DO NOT SPRAY ANY CLEANER OR LIQUIDS ON THE APPLIANCE WHEN HOT.

The appliance MUST be cleaned as instructed below to prevent grease build-up and other food deposits.

A clean and well maintained appliance prevents the risk of grease/fat fires. See INSTALLATION, OPERATION, AND SAFETY INFORMATION section.

AFTER EACH USE: preheat the unit, brush the cooking grids to remove all residue, and operate on high (hood closed) for 10-15 minutes to burn off all grease.

EVERY 10 COOKOUTS: clean the unit as instructed below.

COOKING GRIDS

Before and after each use, clean the cooking grids with a grill brush. Before initial use and periodically, it is suggested that the cooking grids be washed with a mild soap and warm water solution.

INTERIOR

THE **BURNER PORTS** MUST BE KEPT CLEAN TO ENSURE PROPER IGNITION AND OPERATION.

Remove the burner (see the CHECK BURNER ORIFICES section) and clean the ports as required. Also inspect and clean the burner inlet for insects and nests. A clogged burner can lead to a fire in the bottom of the appliance.

The inside of the appliance may be cleaned periodically with oven cleaner if desired. Follow the oven cleaner instructions for proper use.

Be careful not to get oven cleaner on the outside surface of the appliance as it can permanently damage the finish.

EXTERIOR

Stainless steel surfaces when exposed to temperatures produced by the grilling process will change color. The stainless steel will change color from silver to brown and blue. This can be removed by using stainless steel cleaner.

Clean your appliance by first using stainless steel grill cleaner to remove grease and dirt. Always wipe with the grain (See Fig. 27-1). Next, apply stainless steel polish and wipe down using polish wipes to restore the stainless steel color.

If your appliance is installed in a seaside (salt air) or poolside (chlorine) location, it will be more susceptible to corrosion and must be maintained/cleaned more frequently. Do not store chemicals (such as chlorine or fertilizer) near your stainless steel appliance.

Due to the nature of stainless steel, surface iron oxide deposits may appear. Do not be alarmed – these deposits are removable with stainless steel cleaner through prompt and periodic maintenance. If not attended to promptly, permanent pitting may occur.

By following these recommendations, you will enjoy the beauty and convenience of your appliance for many years to come.

DRIP TRAY

The drip collector allows you to brush or scrape residue from the grill's inner liner into the drip tray. Regular cleaning of the grill's interior with oven cleaner will help prevent grease/fat fires.

After each use, wait for the grill to cool and carefully pull out the drip tray to check it. When a tray liner is nearing full, carefully lift it out of the drip tray, lifting with both hands to keep the tray level until it is safely discarded. Then insert a new drip tray liner (see INSTALLATION - INSTALL THE DRIP TRAY section if needed).

If a tray liner is not installed, carefully remove the drip tray and empty the contents. Replace the tray.

Order more drip tray liners through your local Fire Magic dealer.

Note: The foil tray liner is also useful for setting on burners to cover them and catch drippings directly during rotisserie only cooking (if applicable).

PROTECTING YOUR APPLIANCE FROM THE WEATHER

An optional cover will protect your appliance when not in use. Allow to cool before covering. Please specify the model number and serial number of your appliance when ordering a cover.



Fig. 27-1 Wipe with grain

CONVERTING THE GAS TYPE

CAUTION: Make sure the grill is at a safe temperature and isolated from gas and electrical supplies before beginning.

For your safety, exercise caution, and make sure you have adequate hand protection, such as gloves, when handling metal parts.

Apply Conversion Label

This grill comes from the factory configured for one type of gas as marked on the label behind the control panel.

When the grill is converted, the label for the new gas (included at original shipping) MUST be filled out and applied next to the existing label mentioned above.

Convert Regulator

The gas regulator, located behind the control panel, must be set for the type of gas used to fuel the grill. To check the regulator setting, remove the cap in the center of the regulator (Fig. 28-1, A). Holding the cap vertical (see Fig. 28-1, B), the letters at the bottom of the plastic stalk indicate the gas type for which the regulator is currently configured.

If the text on the bottom of the regulator stalk does not match the gas type connected to the grill, remove the stalk from the cap, invert, and replace into center of cap. Replace cap on the regulator, screwing down until snug.

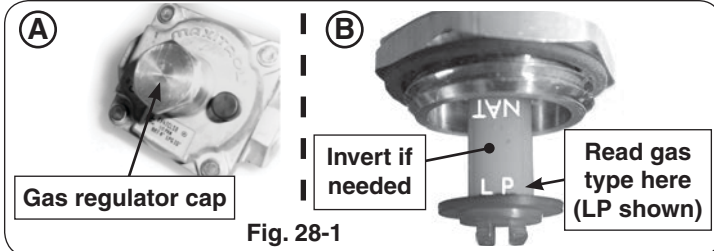

Fig. 28-1

Convert Gas Orifices

When converting the grill to a different gas type, each burner's orifice must be replaced with the corresponding orifice for the new gas.

See Table 1 to determine the proper orifice sizes for each burner.

See the following section for details on orifice conversion.

Important: It is critical to the operation of each burner that its orifice be fully inserted into the center of its orifice opening.

WARNING

HAZARDOUS OVERHEATING WILL OCCUR IF A NATURAL-GAS ORIFICE IS USED WITH PROPANE GAS.

Connect To New Gas Supply

Plumb the unit as appropriate for the new gas supply. (Additional components may be needed for your specific setup.) **Be sure to leak test at all connections.**

Convert/Check Main Burner Orifices

1. Remove the cooking grid and flavor grid from above the burner you are working and set them aside.
2. Locate the burner. Slightly pinch and remove the burner clip (located over the rear center of the burner) from the burner support and set aside.
3. Carefully lift the burner from the burner support and out from the hole in the forward fire wall (see Fig. 28-2).
4. Use a $\frac{3}{8}$ " hex nut driver to remove the exposed orifice (Fig. 28-3). Check orifice. If needed, replace it with the correct orifice for the new gas.
5. Replace the burner by first sliding the open cylindrical end of the burner around the orifice, enveloping it and centering on it, then lower the back end anchor pegs into the anchor peg holes.

Note: It is critical to the continued safe functioning of the burner that the orifice is centered and completely inside the burner gas inlet.

6. Re-install the burner clip around the burner and into the holes in the burner support.
7. Replace the flavor grid and then the cooking grid so that the cut-out section is in front.
8. Repeat these steps for each main burner.

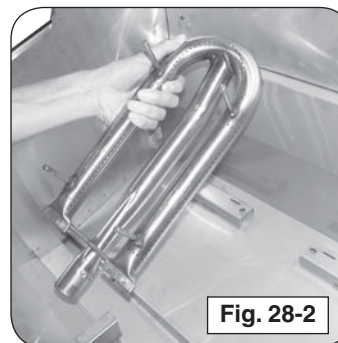

Fig. 28-2

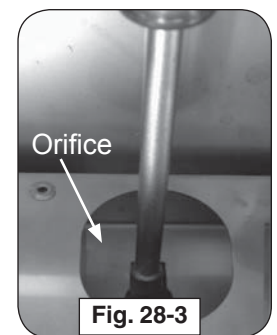

Fig. 28-3

BURNER AIR SHUTTER ADJUSTMENT

Important: Air shutters are preset at the factory based on the gas the grill is built to burn. However, altitude or other local conditions may require air shutter adjustment for proper combustion.

Main Burner(s)

Flames from a properly adjusted main burner with no wind or breeze present will appear fairly steady, consistent, and mostly blue. If the tip of a flame were to turn orange, it should only do so briefly and then become blue again. The flames will appear to burn while touching the burner ports (see Figure 29-1).

If the flames have orange in them and appear to undulate slowly from side to side, or if some of them appear to lift off the burner instead of touching it, then adjust the air shutter, as instructed below.

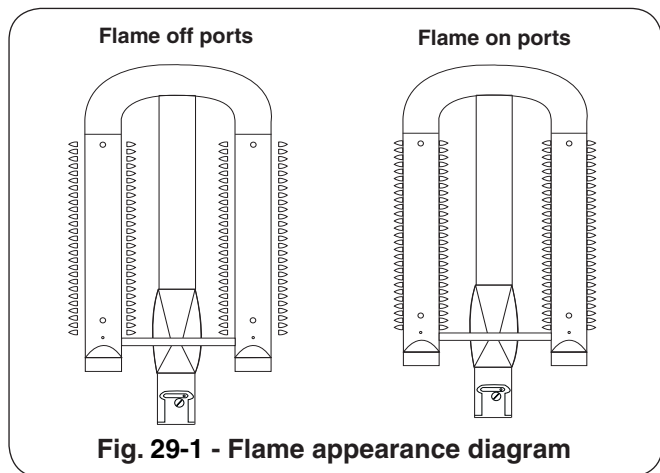

CAUTION: Turn all burner control knobs to the **OFF** position and turn off the gas supply at the source before removing or adjusting a burner.

WARNING

Wait for the burner to be cool or use heavily insulated heat-resistant gloves when handling the burner.

1. Follow the safety precautions and steps for main burner removal in the **CHANGING THE MAIN BURNER ORIFICES** section (steps 1-2).

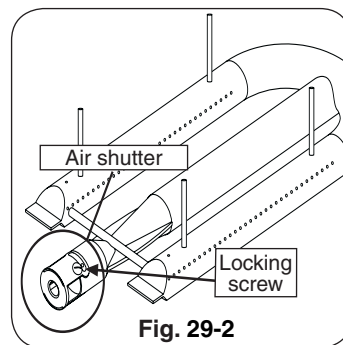

2. Adjust the air shutter opening by loosening the adjustment screw with a screwdriver, then turn the air shutter to open or close it (see Fig. 29-2).

Shutter Setting	Flame Condition
Open too far	Flames shorten and lift off the burner
Ideal setting	Blue flames just touching burner
Closed too far	“Lazy” flames with orange in them

Too large an air shutter opening will allow too much air into the burner, which will cause the flames first to shorten and then to appear to lift up off the ports. For the bottom of the flames to move closer to the ports, close the air shutter more.

If the air shutter opening is too small or closed, the flames will present consistently orange tips and become “lazy,” slowly undulating back and forth.

For propane gas, ideal settings tend to be just slightly open. For natural gas, which generally requires less primary air than propane, the main burner air shutter may be nearly closed.

3. Adjust the air shutter opening and then replace the burner.
4. Follow the lighting instructions in this manual to light the burner.
5. Repeat steps 1-4 until the flames appear to touch the burner ports, burning fairly steadily and mostly blue (see Fig. 29-1).
6. Replace the burner clip, flavor grid, and cooking grid.

Repeat these steps for each main burner.

CONTROL PANEL REMOVAL

1. Turn the control knob(s) to the OFF position and turn off the gas supply to the unit.
2. Pull the control knob(s) from the stems and set aside.
3. Remove the drip tray.
4. Using a Phillips screwdriver, unscrew and remove the control panel fastener screws and washers (located on the left and right front face of the control panel). Retain the screws for later re-installation.
5. Carefully open the control panel by lifting and pulling the control panel from the frame, allowing it to rest on the internal chain(s).

Important: During reinstallation; prior to opening the gas shut-off valve, be sure the control knob(s) are in the OFF position.

IGNITER BATTERY REPLACEMENT

1. Carefully pull out the existing 9-volt battery holder located on the right side of the control panel.

Note: It may be necessary to lift the drawer up slightly before it will pull out.

2. Disconnect the battery from the connector and replace it connecting the new battery and close the drawer (see Fig. 31-1).

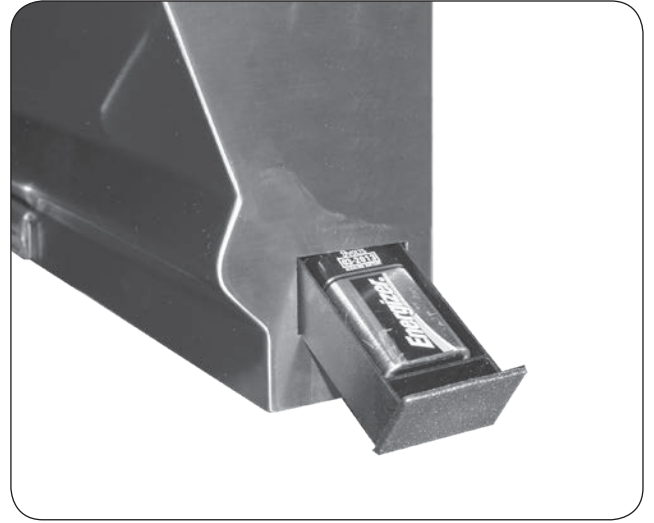

Fig. 31-1 Replace igniter battery

NOTES PAGE

Please use this page to record any information about your unit that you may want to have at hand.

TROUBLESHOOTING

If you have trouble with the unit, please use this list to identify the problem. By trying one or more of the solutions to the possible cause, you should be able to solve the problem. If this list does not cover your present problem, or if you have other technical difficulties with the unit, please contact your local dealer.

PROBLEM	POSSIBLE CAUSE	CORRECTION
Ignition system failure	<ol style="list-style-type: none"> 1. Low battery. 2. Improper air shutter adjustment 3. Ignition wire disconnected 4. Low gas pressure 5. Igniter malfunction 6. Igniter switch malfunction on valve 	<ol style="list-style-type: none"> 1. Replace igniter battery. 2. Adjust air shutters. 3. Plug wires back into ignition switches. 4. Have the gas co. check supply pressure. 5. Contact dealer for replacement. 6. Contact dealer for replacement.
Insufficient heat / low flame	<ol style="list-style-type: none"> 1. Burner ports partially blocked by debris 2. Improper air-shutter adjustment 3. Using propane orifice for natural gas 4. Low gas pressure/flame (propane) 5. Low gas pressure/flame (natural) 6. L.P. regulator hose cracked due to age 	<ol style="list-style-type: none"> 1. Remove burners and clean out ports. 2. Adjust air shutters. 3. Check/change orifices. 4. Shut off all valves, including propane tank, and follow lighting instructions exactly. (See important note* below.) 5. Have the gas co. check pressure at unit. 6. Replace L.P. regulator hose.
Uneven heating	<ol style="list-style-type: none"> 1. Burner ports partially blocked by debris 2. Small spiders or insects in burner 3. Improper air shutter adjustment 	<ol style="list-style-type: none"> 1. Remove burners and clean out ports. 2. Inspect burners and orifices for spider webs or other debris that may block flow. 3. Adjust air shutter.
Burner goes out on LOW	<ol style="list-style-type: none"> 1. Valve "Low" setting needs adjustment 	<ol style="list-style-type: none"> 1. Light burner on HIGH, immediately turn to LOW setting. Remove knob from valve and using a small flat screwdriver, slowly turn the adjustment screw in the stem, a little at a time (30° to 45°), in either direction, until the flame is approximately 1/4" in height from burner ports.

*** Important:** Propane tanks are equipped with a safety shutdown device that may cause low or no gas/flame at the burners if operating and lighting instructions are not followed exactly. **If you suspect the propane tank safety shutoff is in effect:** 1) Shut off all grill valves. 2) Shut off tank valve. 3) Open and close a main burner valve. 4) Open tank valve. 5) Follow the LIGHTING INSTRUCTIONS. Lighting instructions are located in your owner's manual and printed on the grill's metal drip tray. If the problem persists, continue troubleshooting, or contact your local dealer or R. H. Peterson for assistance.

WARRANTY

PETERSON FIRE MAGIC GRILLS AND ACCESSORIES LIMITED WARRANTY

Robert H. Peterson Co. ("RHP") warrants your Fire Magic® grill to be free from defects in material and workmanship.

Fire Magic® cast stainless-steel burners, stainless-steel cooking grids, and stainless-steel housings are warranted for as long as you own your Fire Magic® grill -- **LIFETIME**. (Except as noted below.)

Fire Magic Choice stainless steel tubular burners are warranted for **TWENTY (20) YEARS**.

Fire Magic® brass valves, inner liners, manifold assemblies, porcelain housings (including ovens and barbecue faces), and backburner assemblies (except ignition parts) are warranted for **FIFTEEN (15) YEARS**.

Fire Magic® Electric Grills, including stainless steel grid, and housings are warranted for **TEN (10) YEARS**.

Fire Magic® Infra-red burners, flavor grids, Charcoal stainless steel grills, and Smokers are warranted for **FIVE (5) YEARS**; except for the charcoal pan, charcoal grid, wood pellet screen, thermometer, and ash tray; which are warranted for **ONE (1) YEAR**.

Fire Magic® sideburners and all other Fire Magic® grill components (except ignition and electronic parts) are warranted for **THREE (3) YEARS**.

Fire Magic® ignition systems (excluding batteries), electronic components (including lights and thermometers), and grill accessories are warranted for **ONE (1) YEAR**.

A COPY OF YOUR SALES SLIP FOR PROOF OF PURCHASE IS REQUIRED

This warranty applies to the original purchaser for products which are installed in the United States or Canada and which are operated and maintained as intended for single family residential usage. This warranty is valid only with proof of purchase, shall commence on the date of purchase, and shall terminate (both as to original and any replacement products) on the anniversary date of the original purchase of the product stated on the above schedules.

This warranty covers defects in material and workmanship. This warranty **does not** cover parts which become defective as a result of negligence, misuse, use not in compliance with the Owner's Manual/Installation Instructions, accidental damage, improper handling, improper storage, improper installation, **lack of required routine maintenance** (as specified in the Owner's Manual/Installation Instructions), electrical damage, local gas impurities or failure to protect against combustibles. Product must be installed (and gas must be connected) as specified in the Owner's Manual/Installation Instructions by a **qualified professional installer**. Modifications to products which are not specifically authorized will void this warranty. Accessories, parts, valves, remotes, etc. when used must be Peterson products or this warranty is void. Warranted items will be repaired or replaced at Peterson's sole discretion. This warranty **does not** apply to rust, corrosion, oxidation, or discoloration unless the affected part becomes inoperable.

This warranty **does not** cover labor or labor related charges, except as provided by separate specific written programs from the Peterson Co. All repair work must be performed by a qualified professional service person and requires prior approval of Peterson.

Peterson may require the defective product or part to be returned to the factory to determine the cause of failure. Peterson will pay freight charges if the product or part is determined to be defective. This warranty does not cover breakage in shipment from our (Independent) distributor to its customer if the damage is determined to have occurred during that shipment.

This warranty specifically excludes liability for **indirect, incidental, or consequential** damages. Some states and provinces do not allow the exclusion or limitation of incidental or consequential damages, so the above exclusion may not apply to you. This warranty gives you specified legal rights, and you may have other rights that vary from state to state or province.

For additional information regarding this warranty, or to place a warranty claim, contact the R. H. Peterson dealer where the product was purchased.

When contacting your Peterson dealer or the R. H. Peterson Co., please provide the following information:

- Your name, address, telephone number, e-mail
- Sales receipt showing where purchased and date purchased
- Model number, serial number of product, date code
- Relevant information: installer, additions, repairs, when defect was first noted

**TO REGISTER YOUR PRODUCT ONLINE GO TO: WWW.RHPETERSON.COM,
AND CLICK ON PRODUCT REGISTRATION. THANK YOU FOR YOUR PURCHASE.**

Quality Check			Date: _____		
Burner Orifices	Nat.	L.P.	Leak Test: _____	Model#: _____	
Main:	_____	_____	Burn Test: _____	Serial#: _____	
Other:	_____	_____	Gas Type: <u>Nat. / L.P.</u>	Air Shutter: _____	
				Inspector: _____	