

Fig. H

! IMPORTANT NOTES

1. If the cycle time is exceeded, the letter folder machine will automatically shut down and the overheat LED light (red) will flash until it is safe to resume. Cycle time: 8-15 minutes (Fig. I).

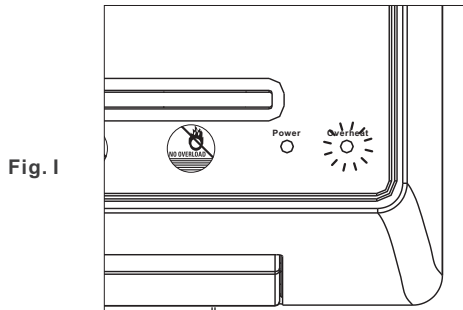

Fig. I

2. Please observe all printed precautions and warnings.

SPECIFICATIONS

POWER: 100-240V/50-60 Hz AC Adapter

CAPACITY:

Auto Feed: Max. 40 sheets (20 lb. Bond / 75 G/M2)

Manual Feed: Max. 3 sheets at a time (20 lb. Bond / 75 G/M2)

TECHKO®

**HIGH SPEED PAPER FOLDER
MODELS : LF291**

OPERATION INSTRUCTIONS

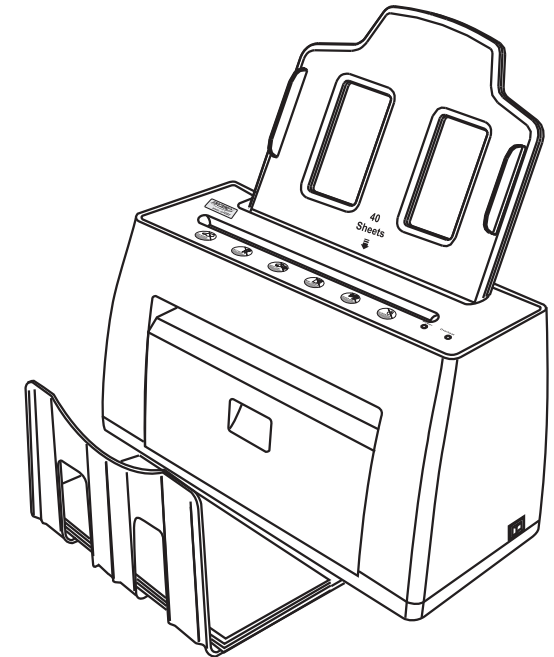

Customer Service :

1-888-8TECHKO (1-888-883-2456)

Website: www.techkomaid.com

Mfg. By **TECHKO®**

11 Marconi Street,

Irvine, CA 92618

MADE IN CHINA

Before operating this unit, please read all of the instructions, including important warranty information.

IMPORTANT SAFETY INSTRUCTIONS

Your safety as well as the safety of others is important to TECHKO. In this manual as well as on the product are important safety instructions. PLEASE READ ALL SAFETY INSTRUCTIONS BEFORE OPERATING.

CAUTIONS



Product is not intended for use by children (product is not a toy). Keep children and pets away from letter folding machine.



Do not use solvents, cleaning degreasers or any chemicals to clean the letter folding machine.



Don't overload paper folder. Maximum 3 sheets at a time.



Avoid touching the document feed slot with hands. Never insert hands or fingers into paper folding slot.



Avoid hair touching the document paper folding slot. Keep hair/face away from the document paper folding slot.



Keep aerosol products away from letter folding machine. Do not use flammable, petroleum-based or aerosol cleaners on or near this product. Some agents may combust causing serious injury.



Avoid clothing touching the document feed slot. Keep personal and loose objects (jewelry, ties, etc.) away from folding slot.



Operate this letter folding machine with a 8-15 minutes on, and a 20-30 minutes off cycle.



Always unplug the unit and make sure the master control switch is on the OFF position while not in use in order to prevent accidents.



Do not operate the unit with a damaged power supply cord.

OPERATION

1. Remove the unit from its packaging.
2. Make sure the paper loading tray is inserted in place correctly (Fig.C / Fig.D). Insert the paper loading tray into the rear part of the auto feed slot, and carefully pull out the bottom Basket.
3. Plug into a power outlet and then put the master control switch in the ON position. The green power LED light will illuminate.

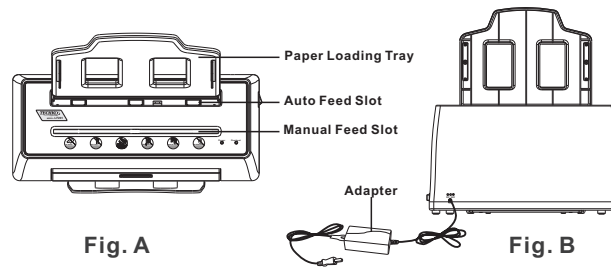

Fig. A

Fig. B

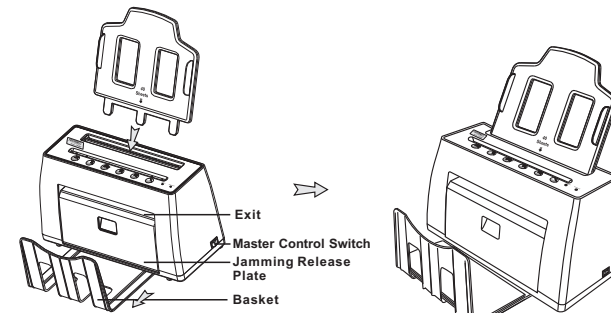

Fig. C

Fig. D

4. Connect the AC adapter with the unit (Fig. B), then plug the AC adapter with the power source. Once the power is connected, then the unit is ready to be used.
5. Auto Feed: Max. loads 40 sheets at a time and automatically feeds 1 sheet at a time. Line up stack of papers well, then pull the paper loading tray to load papers easily, then release the paper loading tray (as Fig. E). The infrared sensor inside the auto feed slot will detect the

papers (this may take a few seconds) and pull the papers into the unit one after another automatically.

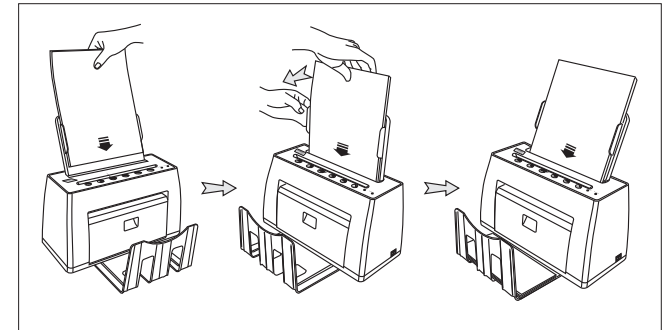

Fig. E

6. Manual Feed: Max. Loads 3 sheets at a time. Line up the paper(s) (if 2 or 3 sheets) into the manual feed slot and release paper(s) to fall freely into the slot. The infrared sensor inside the manual feed slot will detect the paper(s) (this may take a few seconds) and pull the paper(s) into the unit (Fig. F).
7. The folded paper(s) will come out from the exit, then fall into the basket (Fig. G).

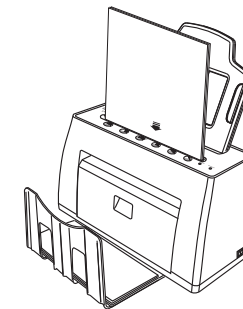

Fig. F

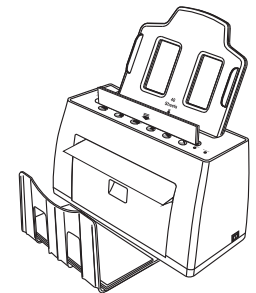

Fig. G

IF PAPER JAMS

In the event of a paper jam, please open jamming release plate (Fig. H) to remove the jammed paper(s), then close the jamming release plate.