

GENERAL PUMP *A member of the Interpump Group*

DCFSCP18/GZ

Flat Surface Cleaner



SPECIFICATIONS



Part Number	DCFSCP18 DCFSCP18GZ
Operating Pressure	1,000 - 4,000 PSI
Max Flow	8.0 GPM
Dimensions	70"x18.3"x18.3"
Weight	17 lbs

FEATURES / BENEFITS

- Compensating Gun Feature
- Full 18" cleaning path
- Heavy-duty anodized aluminum components
- Rugged ABS cover

WARNING: Read Before Operating Machine
 Always wear protective eye wear
 Keep clear of rotating nozzles
 Never lock trigger gun open with any device
 Drain water in cold weather to avoid freezing
 Tampering with any part of this machine will void all warranties

PARTS LIST

NO.	PART NO.	DESCRIPTION	QTY.
1	2630010	PLATE, RETAINING	1
2	2540023	COLLAR, SPLIT	1
3	2540020	BLOCK, HANDLE	2
4	2660047	GRIP, HANDLE	1
5	2660046	PLUG, HANDLE	1
6	2200055	SHCS, M8 X 30	4
7	2200054	SHCS	1
8	2200053	NUT, M8X1.25	4
9	D10009	PLUG, 3/8 X 3/8-M	1
10	D10004	QC, 3/8 X 3/8 NPT-M	1
11	2200047	BOLT, M6	8
12	2203406	WASHER, M6	8
13	2660049	BRUSH ASSY	1
14	2530052	ARM, ROTRAY, ASSY, 18"	1
15	2660119	Deck 18"	1
16	2202010	PIN, 55MM, w/RING, SS	2
17	2200058	HHCS, M6 x 60	2
18	2200026	NUT, NYLOK, M6	2
19	2200018	WASHER, M6	4
20	2702026	HOSE, FSC. 18"	1
21	2203507	WASHER	1
22	2540021	HANDLE, LOWER	1
23	2400007	LABLE, GREASE	1
24	DCG4000FSC	GUN, FSC, 20"	1
25	2540037	HANDLE, FSC, UPPER	1
26	2400013	LABLE, SWIVEL	1
27	2103220	SWIVEL (DCFSCP18GZ)	1
	2103221	SWIVEL (DCFSCP18)	1
28	D40015	FILTER, IN-LINE, SST (DCFSCP18GZ ONLY)	1

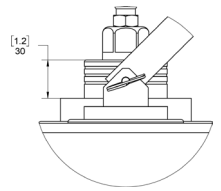
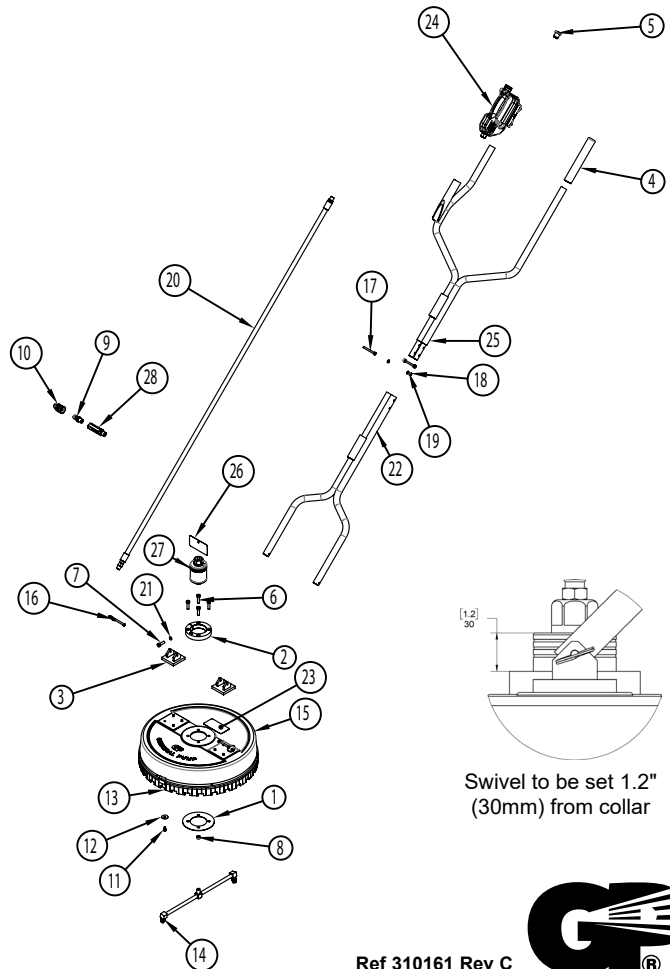

Swivel to be set 1.2" (30mm) from collar

REPAIR KITS

Rotary Head Kit - Major:

P/N 2100372 (DCFSCP18GZ)

P/N 2100373 (DCFSCP18)

Includes items 2, 3, 4, 5, 6, 7, 8, 9, 10, 11, 12, 13, 14, 15 and 17

Rotary Head Kit - Minor:

P/N 2100203

Includes items 8, 9, 11, and 13

Complete Rotary Head Kit:

P/N 2103220 (DCFSCP18GZ)

P/N 2103221 (DCFSCP18)

Includes all items

Optional Caster Kit:

P/N 2100200

NO.	PART NO.	DESCRIPTION	QTY.
1	2500010	HOUSING (DCFSCP18GZ)	1
	2500011	HOUSING (DCFSCP18)	
2	2520030	RETAINER, BEARING	1
3	2520028	RETAINER, BEARING	1
4	2520027	SPACER, BEARING	2
5	2640004	BEARING (DCFSCP18GZ)	2
	2640015	BEARING (DCFSCP18)	
6	2701012	O-RING	1
7	2701011	O-RING	1
8	2701010	O-RING	1
9	2720007	SPRING	1
10	2530008	PIN	2
11	2530007	STEM, SMALL	1
12	2520029	SNAP RING	3
13	2710000	BACK UP RING	1
14	2520113	STEM	1
15	2200092	SCREW, M5 X 16	3
16	2200050	WASHER	3
17	2500012	RETAINER, BEARING	1
18	2640012	ZERK, GREASE (DCFSCP18GZ)	1

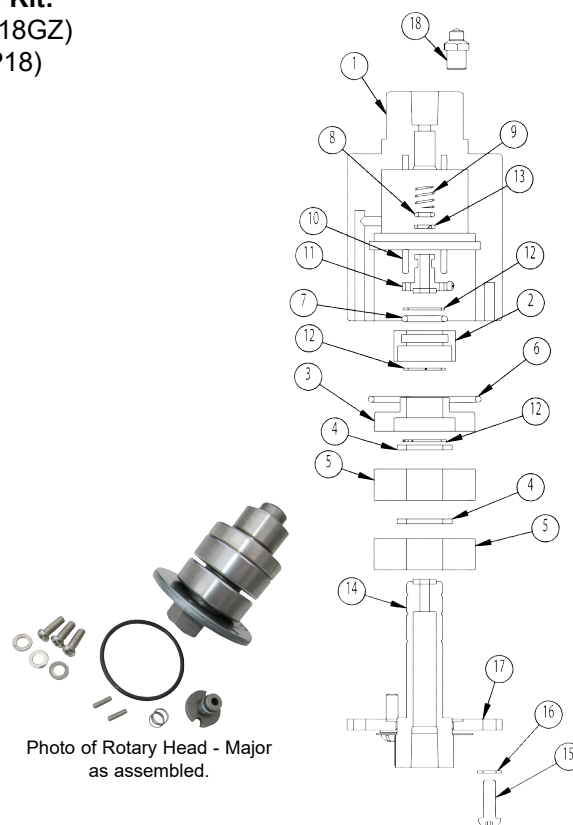

HARDWARE KIT 2100253

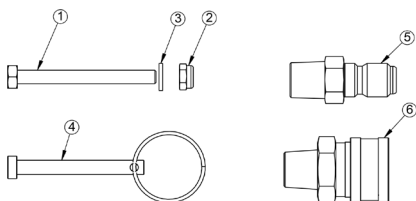

NO	PART NO	DESCRIPTION	QTY
1	2200058	HHCS, M6x60	2
2	2200026	NUT, NYLOK, M6	2
3	2200018	WASHER, M6	4
4	2202010	PIN, 55MM, W/RING, SS	2
5	D10079	PLUG, 3/8 x 3/8-M	1
6	D10075	COUPLER, 3/8 x 3/8-M	1

ASSEMBLY / OPERATING INSTRUCTIONS

1. Bolt the two halves of the handle together with the two M6 x 60mm long bolts, nylok nuts and four washers.
2. Connect the handle to the brackets on the deck with the two 55mm long pins and rings.
3. Using thread sealant on hose's male threads, connect the hose to the swivel on the deck.
4. Again, using thread sealant, attach the in-line filter to the inlet of the gun.
5. Connect to Pressure Washer.
6. Turn water on and open valve. Open trigger gun for flow of water through nozzles. Nozzles must have flowing spray. If not, remove tips and clean; reassemble, making sure that groove of nozzle is parallel to spray bar. Use thread sealant when installing nozzles.
7. Start Pressure Washer. The Hammerhead is ready for operation.
8. Walk slowly behind the Hammerhead cleaning as you go. If striping occurs, slow down your pace.
9. Periodically check weep hole on bottom of swivel. Water will seep slowly; if water shoots out, stop and replace seals. Swivel assembly can be rebuilt.
10. For maximum effectiveness keep spray tips clean. If the machine vibrates, stop and clean spray tips.
11. For the DCFSCP18GZ only: Grease the swivel with one or two grease gun pumps every 200 hours (or once about every 30 days of use). Use No. 2 general purpose waterproof lithium grease. For hot water applications, use a high quality high temperature grease.

NOTE: For the DCFSCP18GZ only: after 50 hours of use, remove the in-line filter, take apart and clean filter screen.

**DO NOT ALLOW MACHINE TO REMAIN STATIONARY
ON SOFT SURFACES SUCH AS WOOD.**

STORAGE NOTE

When storing the FSC for a few weeks or months, it is best to drain as much water as possible. Disconnect the FSC from the pump and stand the handle up. Clamp the gun trigger open and let the water run out. Shop air can also be used at the gun inlet to force out the water.

Caution: Striking any raised obstacle during operation will damage machine. If contact does occur and results in vibration when operating machine, STOP and replace spray bar. Continued operation could result in serious injury or damage to machine.