

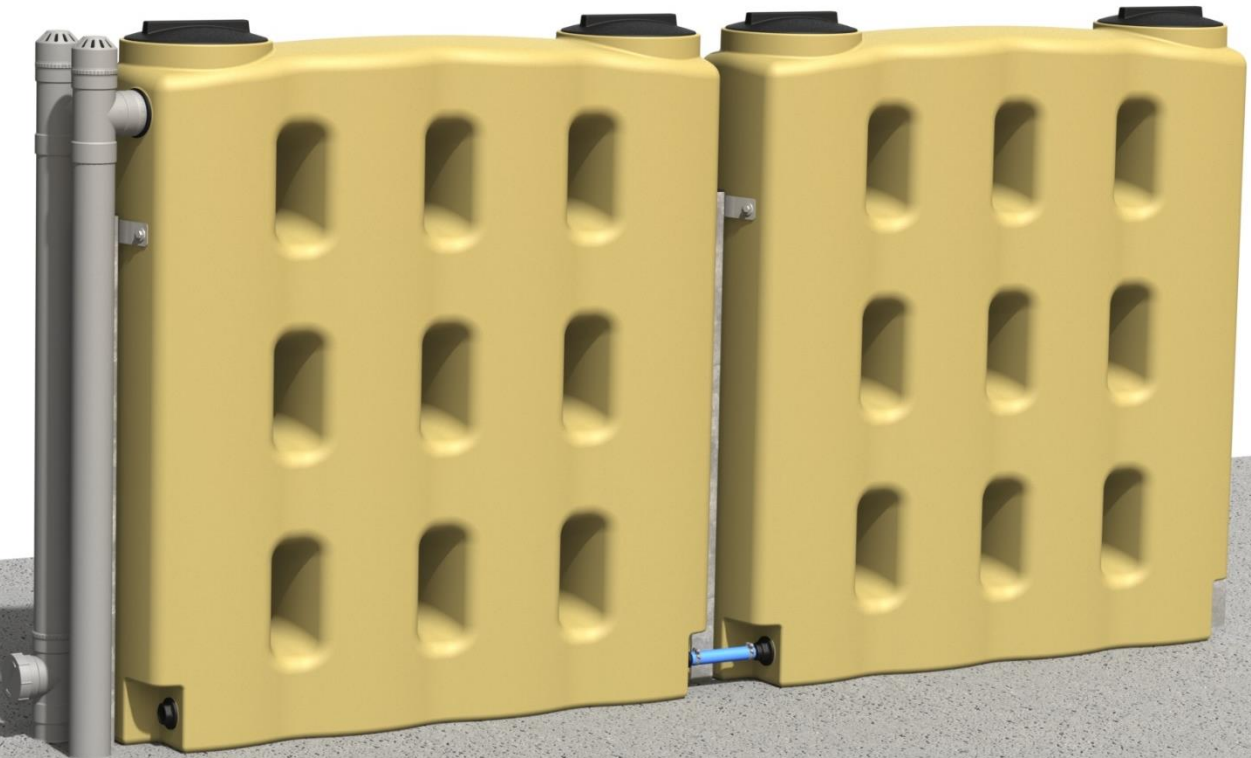

BWT SLIMLINE TANKS

INSTALLATION GUIDE 2023

PRODUCT WARRANTY



BIGWATERTANKS.CO.NZ

0800BIGWATER

Contents

1. Basic Installation Information	3
1.1. Introduction	3
1.2. Plastic Tank Specifications	3
1.3. Lifting Instructions	3
2. Installation Ground Preparation	4
2.1. Above Ground Installation	4
2.2. Partial Buried Installations	4
3. Plumbing Connection Information	5
3.1. Recommended Installation Drawing	5
3.2. Incoming Stormwater Connections	5
3.3. Overflow Connections	6
3.4. Detention Orifice Outlets	6
3.5. Rubber Tank Seals	6
3.6. Plumbing Connections	6
3.7. Inter-tank Connections	7
3.8. Additional outlets	7
3.9. Float Valves	7
3.10. Pumps	7
4. Seismic Restraints (Posts)	8
5. Seismic Restraints (Brackets)	9
6. Product Codes and Spare Parts	11
7. 10 Year Warranty	12

1. Basic Installation Information

1.1. Introduction

Big Water Tanks Limited manufactures this **BWT Slimline Water Tank** to the highest quality and have created this guide for most typical installations. It is very important that these instructions are read prior to installation as these instructions are required to maintain any warranty and incorrect installation may result in tank failure and/or instability due to weather or seismic activity if this product is not securely braced.

A full **BWT Slimline Water Tank** can weigh over 1300kg full and has a high centre of gravity so ensure you select a stable installation area.

Installation must not be done over any services (electrical, water, septic, or sewage etc.)

1.2. Plastic Tank Specifications

Details:	
Tank Volume:	1,200L (with internal overflow elbow)
Tank Width:	1,760mm ± 20mm
Tank Height:	1,900mm ± 25mm
Tank Depth:	440mm ± 10mm
Manhole Size:	255mm screw lids
Outlet Size:	32mm BSP Female Factory Fitted
Material:	MDPE (Medium Density Polyethylene)
Material Standards:	AS/NZS 2070 – Food Contact Requirements AS/NZS 4020:2005 – Potable Drinking Water AS/NZS 4766:2020 – Polyethylene Storage Tanks for Water
Material UV Rating:	UV20

1.3. Lifting Instructions

BWT Slimline Water Tanks should be lifted in a safe manner and only when empty, the tank weighs approximately 80kg so it would require a trolley or many people to physically move the **BWT Slimline Water Tank**.

The recommended “high-lift” (digger, crane, HIAB, Helicopter, etc) method is using 2 x 3m or longer Lifting Slings though the top two outside “kiss-offs” (the large holes) though the tank.

2. Installation Ground Preparation

2.1. Above Ground Installation

BWT Slimline Water Tank can be installed on a concrete pad or on a compacted base of GAP7 over well compacted subsoil and should be retained with timber boxing or below Finished Ground level to ensure that the base material cannot washout.

Seismic restraints

Seismic restrains **must be installed** if the tank is above ground, please refer to the seismic restraints chapter for more details and options.

2.2. Partial Buried Installations

BWT Slimline Water Tank can be partially buried in the ground up to 500mm from the base.

- The tank will need to be installed onto a compacted solid base with a layer of compacted and level GAP7 or SAP7 of at least 100mm thick.
- The tank will then need to be filled to at least the depth of the bury or finished ground level.
- A filtered drain coil should be installed around the tank and run into a drain if there is any likelihood that the buried area could become waterlogged or if the tank is a detention tank and is likely to be empty regularly especially in wetter weather conditions.
- The tank should be Backfilled with SAP7 or GAP7 to allow for drainage, light compaction of the material should be done in layers of 100mm and needs to be at least 150mm thick around the tank.
- A thin 50mm layer of topsoil can be used on top of the backfill to grow vegetation with small non-invasive root systems and if a lawn is grown up to the tank ensure a timber boxing is used to prevent grass trimmers from damaging the tank overtime.
- A concrete slab can be poured up to the tank however the tank must remain completely full until the concrete has cured for at least 7 days and the slab should be formed to direct surface water away from the tank.
- It is recommended to install a PVC pipe above the ball valve on the tank to enable the valve to be closed.

Seismic Restraints

Seismic restraints should not be required if the tank is buried 500mm (so the lower “kiss-off” or through holes are just buried) as per the above instructions.

3. Plumbing Connection Information

3.1. Recommended Installation Drawing

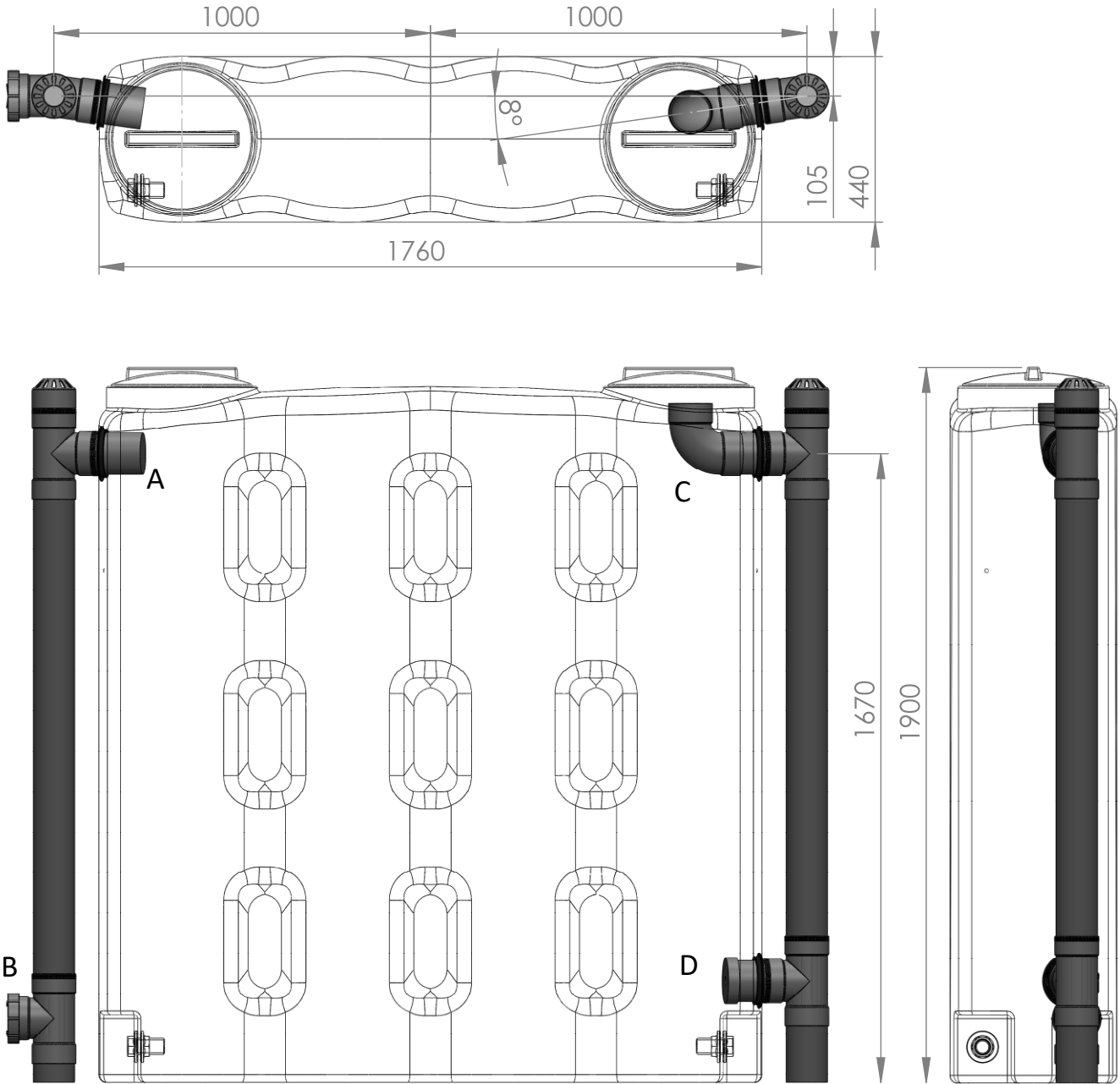

3.2. Incoming Stormwater Connections

PVC pipework for the **BWT Slimline Water Tanks** can be installed in many different areas of the tank; If the Steel Pole Seismic Restrain system is used, then it is recommended to install 100mm PVC DWV pipework 100-105mm from the back or front edge of the tank and to enter the tank squarely at roughly 8° as per the drawing in 3.1. with a 100mm Rubber Tank Seal. It is required that the tank have a vent on the inlet or outlet (A).

It is recommended to install a flushing eye on the incoming charged pipeline (B).

3.3. Overflow Connections

PVC pipework for the **BWT Slimline Water Tank** overflow should be installed as per the instructions for the incoming stormwater connection, however, an internal elbow is required to attain the full 1200l of water storage and the Invert (height of the edge of the elbow or of the water level) should be at 1800mm from ground level. The drawing in 3.1. is using a 90° Inspection port into the tank where often a 88° Junction fitting would be used altering that internal height by changing the angle, please measure onsite to 1800mm. (C)

Overflows must be piped away from the tank to prevent erosion or connected to the stormwater system.

3.4. Detention Orifice Outlets

Slow-release orifices required for stormwater management can be installed into the tank with a junction at any height, using a 100mm Rubber seal and it is recommended to install these on the same line as the overflow as per the drawing in 3.1. Height specifications would be supplied by your stormwater engineer and installing the office pipe and cap should be done prior to standing or with the tank on its side for better access. An internal pipe reducer can be used with a cap can be used to prevent internal access difficulties. (D)

Minimum Hole Gap: 500mm centres to another hole

3.5. Rubber Tank Seals

Care needs to be taken in drilling rubber tank seals, a hole saw must be used to the manufacturers specification, because failure to do so will result in leaks and will not be covered by our warranty. Most tank seals have the hole saw size labelled on the product alternatively, visit the manufacturers website for correct sizing.

3.6. Plumbing Connections

BWT Slimline Water Tanks must be connected with a flexible hose, this does not include plastic pipe like alkathene or MDPE. Big Water Tanks have hose kits available, or some plumbing merchants have flexible tank connection kits; each tank has 2 x 32mm BSP female fittings.

Thread tape is required on all threads. The tank fitting must be held with the appropriate tool when tightening a fitting into the tank fitting.

Tank plugs are not supplied with the tank.

3.7. Inter-tank Connections

Inter-Connection kits are available from Big Water Tanks Limited:

Product Code: BWTSL-ITCC

1 x 210mm BLUE 32mm Flexible Hose

2 x HAN-HTT32 Hansen 32mm Hose Tail

2 x HAN-35-50/12W4P SS Hose Clamp

Important Note:

When installing multiple tanks, the overflow should be installed into the same tank as the water inlet, if this is impossible, each tank requires a 100mm inter-connection with rubber tank seals at the top to enable overflow from tank to tank, however, with the proximity of the tanks this is quite hard to install.

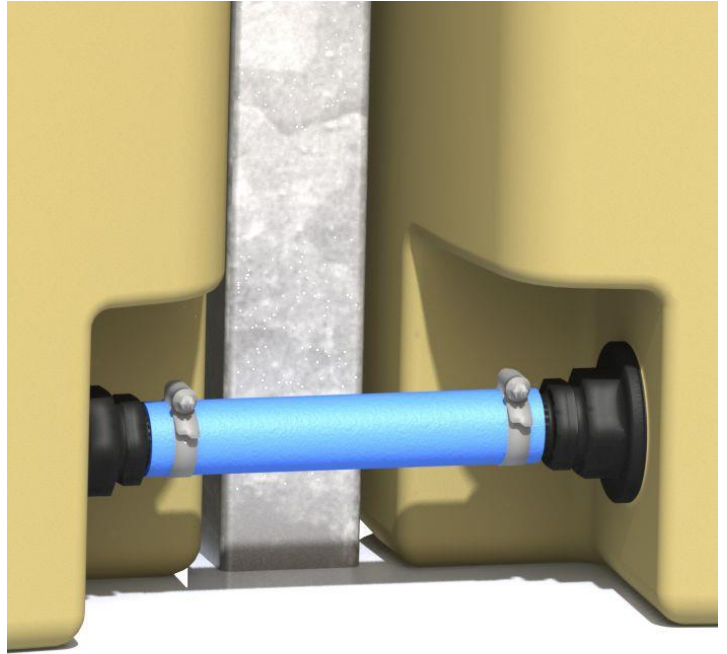

3.8. Additional outlets

Additional outlets can be added to the tank, fittings should be installed a minimum of 150mm away from another fitting and should be installed on reasonably flat areas. The fittings can be installed using standard tank fittings (bulk-heads) up to 50mm BSP maximum however access inside the tank is very limited and EZY Tap fittings are installable from the outside of the tank, but these require correct installation and a flexible hose to be connected to them.

3.9. Float Valves

Float valves can be installed into the side wall of the tank for filling.

3.10. Pumps

External pumps are recommended and must be connected by flexible hoses, however an internal submersible pump supported by the base of the tank is satisfactory.

4. Seismic Restraints (Posts)

Seismic Post Kits are available for the [BWT Slimline Water Tanks](#), the recommended installation instruction is to cast the posts into 900 deep and 400 diameter holes, with the post buried 600mm into the concrete, and a minimum 100mm thick concrete slab, as per the drawing below. The important measurement is 1360mm from finished floor level to the predrilled holes in the post and posts on an 1860 centre.

The Stainless Steel Brackets are attached to the posts with M10x20mm SS bolt and Nut, the bolt and nut are installed through the top of the post and then a plastic post cap is attached. Holes in the Stainless-Steel bracket plates are slotted to allow 12mm of adjustment up or down to line up with moulded in inserts in the tank, and brackets are “bent” onsite to fit to tank profile and attached with M10x20 Hex Bolts with Washers.

Post are Mild Steel Galvanized 75x75x2.5

The minimum concrete slab strength is 20MPa with mesh. 2300mm concrete width for one tank with an additional 1860mm per additional tank.

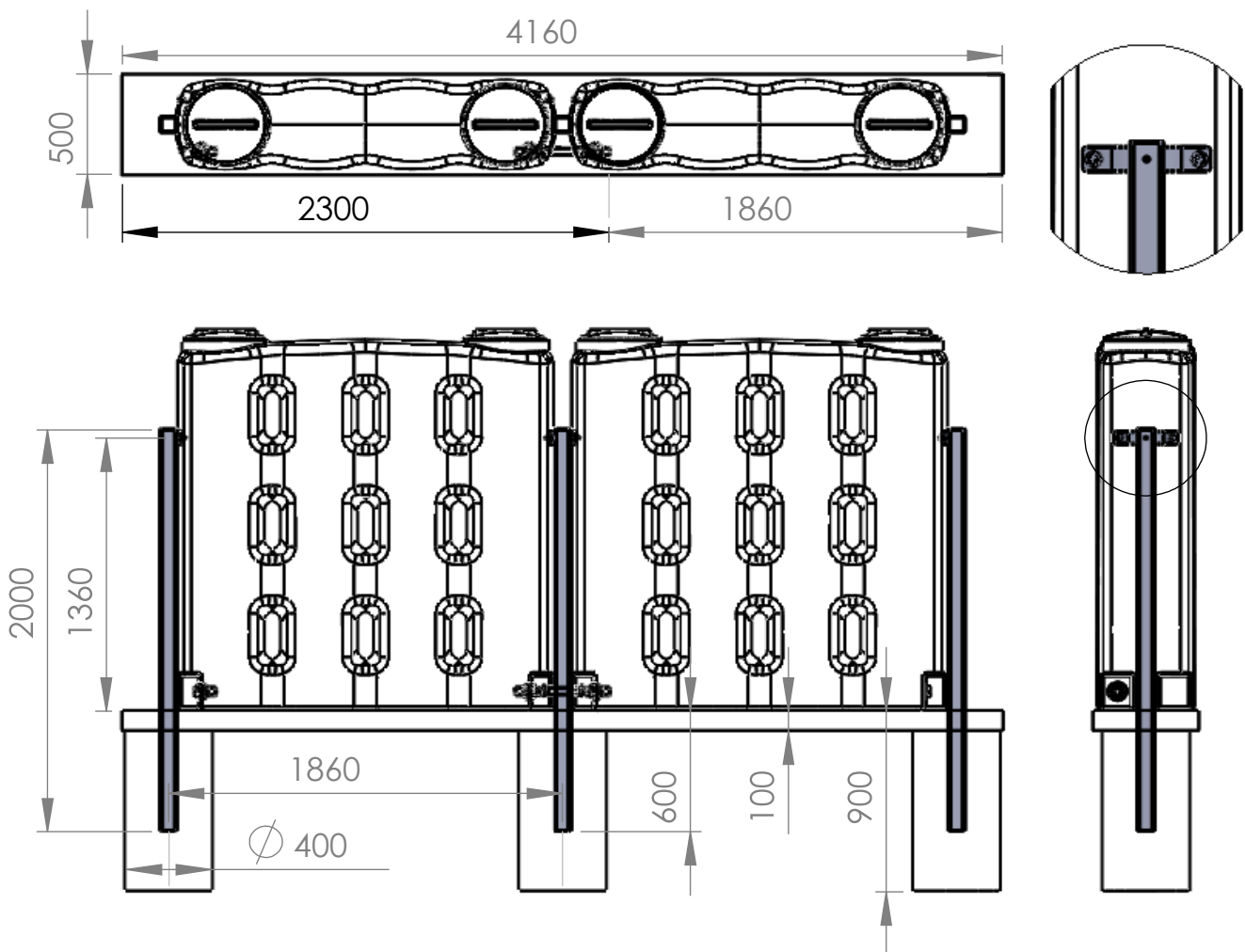

5. Seismic Restraints (Brackets)

Seismic Wall Brackets are available for the [BWT Slimline Water Tanks](#). The recommended installation instruction is to have a solid filled concrete block wall with a minimum 140mm thick, with a tied to the wall a minimum of 100mm thick slab to support the tank, with a minimum 20MPA and mesh, alternative well compacted GAP 7 to solid ground at least 100mm thick and retained so it cannot wash out.

The Stainless-Steel Brackets are attached to the wall with a M12 fixing with a minimum 100mm deep anchor, chemset or similar attachment anchor. The brackets require the heavy duty 65mm Square Stainless-Steel Washer to fix to the concrete and prevent the bracket bending at the wall fixing. It is recommended to install the brackets at 1360mm from finished floor level. Holes in the Stainless-Steel bracket plates are slotted to allow 12mm of adjustment up or down to line up with moulded in inserts in the tank, brackets are “bent” onsite to fit to tank profile and attached with M10x20 Hex Bolts with Washers. For Joining tanks, 2 opposing brackets are attached behind the Stainless-Steel Washer.

The minimum concrete slab strength is 20MPA with mesh. 2140mm Concrete width for one tank with an additional 1860mm per additional tank

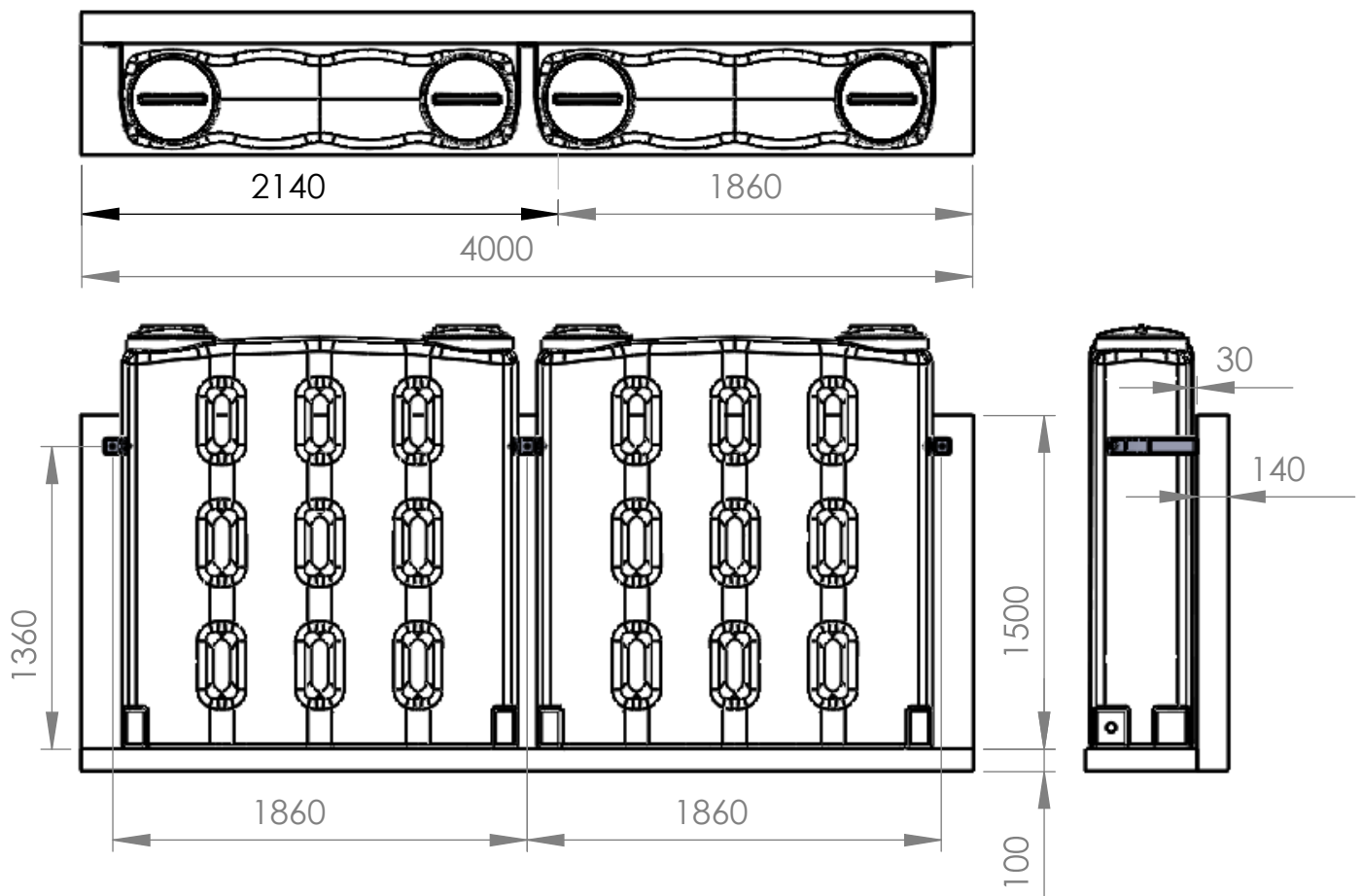

6. Alternative Seismic Restraints

We have supplied a few of options to restrain the BWT Slimline Water Tank and seismic restraints can be installed in several ways however the onus upon the installer to confirm that the structure the tank is being installed to be suitably rigid and strong enough to support they tank in the event of a seismic event and/or to support the tank in everyday use. It may be recommended to have an engineer design a specific solution for your site if required.

6.1. Between Structures

The Tank can Be installed in a space between two rigid structures on well compacted ground with a suitable base as above instructions. Strapping may not be required in this situation however that depends on the gap between the structures.

6.2. Other Single Sided Structures

Against a timber framed building:

If the tank is installed adjacent a timber framed building brackets would need to be installed into rigid structural timber, attaching to weather boards would not be acceptable.

Timber Fencing:

Timber Fencing can be used to support the tank however it is required that the posts be sufficiently concreted into the ground and a supporting rail be fastened to the posts to secure tanks to.

Strapping:

Stainless Steel Seismic Strapping can be used to fasten the tank to a building, or fence, it is recommended to install two straps per tank fastened with suitable anchors to the structure. Please ensure all water tightness regulations are met.

- Install 2 Straps (per tank) to the structure where the top two outside through holes would be prior to installing the tanks is easier (approximately 1500mm from Ground Level)
- Wrap straps thought this hole once the tank is in place then fasten strap to the structure around the outside the tank.

7. Product Codes and Spare Parts

Product Code	Product Description	Colour/ Material
BWTSL-MG	1200l Slimline Water Tank	Mist Green
BWTSL-HG	1200l Slimline Water Tank	Heritage Green
BWTSL-BL	1200l Slimline Water Tank	Black
BWTSL-BE	1200l Slimline Water Tank	Beige
BWTSL-LG	1200l Slimline Water Tank	Light Grey
BWTSL-DG	1200l Slimline Water Tank	Dark Grey
BWTSL-SG	1200l Slimline Water Tank	Slate Grey
BWTSL-ITCC	1200l Slimline Inter-tank Connection Kit 32mm 2 x 32mm Hose Tails 2 x SS Hose Clamps 1 x 210mm long 32mm Blue Hose	Multiple
BWTSL-POST	1200l Slimline Post 75x75 x 2m Long (One unit)	Galv Steel
BWTSL-POSTBR	1200l Slimline Post Bracket Kit End 2 x Stainless Steel Bracket 6 x M10x20 SS Bolts 6 x M10 SS Washers 2 x M10 SS Nut 2 x Black Plastic Post Cap	SS + Plastic
BWTSL-WALLBR	1200l Slimline Wall Bracket Kit 2 x Stainless Steel Wall Bracket 4 x M10x20 SS Bolts 4 x M10 SS Washers 2 x M12x65 SS Square Washer	SS

8. 10 Year Warranty

Big Water Tanks Ltd (BWT) warrants to the original purchaser that the tank will be free from material defects arising from the manufacturing process for a period of 10 years from the date of purchase, and BWT may, at its sole discretion, replace or repair a defective tank during that period subject to the following conditions.

The Warranty is void if:

- It is not installed correctly.
- It is not used for ambient temperature water.
- It is not used for potable water storage.
- The base support degrades or washes out.
- It is moved or handled incorrectly i.e., with water in it etc.
- Degrades due to force majeure (bad weather, earth movements, natural disasters, roots or tree damage, fire, vermin).
- It is not connected with plumbing flexible connections.

The following is excluded from the warranty:

- Inlet holes, overflow holes, or holes created on-site.
- Change of colour over time.
- Removable Lids.
- Reasonable weathering.
- Consequential loss or damage including but not limited to and buildings, production or the like.

Any defect must be reported to Big Water Tanks Limited within 5 days of occurrence with photographs of the defects.