



OVAL GEAR

Medium capacity positive displacement
Mechanical Flowmeters

INSTRUCTION MANUAL

**Models: 1" (025), 1½" (040), 2" (050)
& 2" (050E) (Extended flow range)**



1.0 General		Page
1.1	Overview	2
1.2	Operating principal	3
1.3	Specifications	4
2.0 Installation		
2.1	Mechanical installation	5
2.1.1	Meter & totaliser orientation	5
2.1.2	Flow conditioning & locations	6
3.0 Commissioning		7
4.0 Maintenance		7
4.1	Disassembly of meter & exploded view	8
4.2	Inspection	9
4.3	Re-assembly of meter	9
4.4	Spare parts list	10
5.0 Fault Finding		11
5.1	Trouble shooting	12

1.1 Overview

The Oval Gear meter is a precise positive displacement flowmeter incorporating a pair of oval geared rotors. These meters are capable of measuring the flow of a broad range of clean liquids. Stainless Steel flowmeters are suited to most water based products and chemicals and aluminum meters are suitable for fuels, fuel oils & lubricating liquids.

Mechanical oval gear meters are fitted with both a Primary and Secondary rotor. The Primary rotor has an extension shaft with pinion gear that drives the mechanical register via a reduction gearbox.

This series of 1" (25mm), 1½" (40mm) and 2" (50mm) flowmeters is available with either an M3 (4 Digit) register which reads in Litres or an M4 (4 Digit) register which reads in US Gallons.

The M3 register fitted to 1" (25mm) & 1½" (40mm) meter has
4 digit resettable totalizer reading to 9999.9 Litres (decimal place is read off vertical Vernier scale).
8 digit accumulative totalizer reading to 99,999,999 Litres.

The M4 register fitted to 1" (25mm) & 1½" (40mm) meter has
4 digit resettable totalizer reading to 9999.9 US Gallons (decimal place is read off vertical Vernier scale).
8 digit accumulative totalizer reading to 99,999,999 US Gallons.

The M3 register fitted to 2" (50mm) meter has:
4 digit resettable totalizer reading to 99,999 Litres (x 1 Litre is read off vertical Vernier scale).
8 digit accumulative totalizer reading to 999,999,99 (0) Litres. (x 1 Digit not shown)

The M4 register fitted to 2" (50mm) meter has:
4 digit resettable totalizer reading to 99,999 US Gallons (x 1 US Gallon is read off vertical Vernier scale).
8 digit accumulative totalizer reading to 999,999,99 (0) US Gallons. (x 1 Digit not shown)

The 2" (50mm) flowmeter is also available with an optional V series 5 digit mechanical register (Litres ONLY). The V-series register is not available for the 1" (25mm) & 1½" (40mm) mechanical flowmeters due insufficient torque output from these smaller flowmeters to meet the torque required to drive the V-series mechanical register.

The V1 register fitted to 2" (50mm) meter has:
5 digit resettable totalizer reading to 999,999 Litres (Last x 1 Litre is read off vertical Vernier scale).
8 digit accumulative totalizer reading to 999,999,99 (0) Litres. (x 1 Digit not shown)

The V1 register is ONLY available in LITRE increments and is NOT available for US Gallons

1.2 Operating Principle

The Oval gear are positive displacement flowmeters where the passage of liquid causes two oval geared rotors to rotate within a precision measuring chamber and with each rotation a fixed volume of liquid is displaced passing through the meter. Magnets embedded within the rotors initiate a high resolution pulse train output. The pulse output can be wired directly to process control and monitoring equipment or can be used as an input to instruments supplied with or fitted directly to the meter.

The benefits of this technology allow precise flow measurement and dispensing of most clean liquids irrespective of their conductivity, with other liquid characteristics having nil or minimal effect on meter performance. This metering technology does not require flow profile conditioning as required with alternative flow technologies making the installation relatively compact and low cost.

OPERATION :

Liquid travels around the crescent shaped chambers created by the rotational movement of the rotors

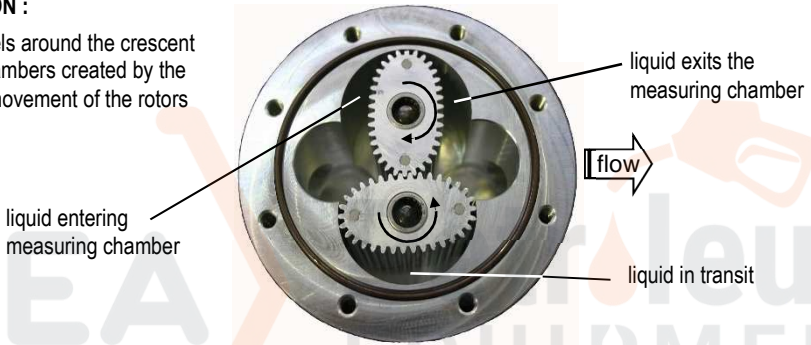

Oval Principle

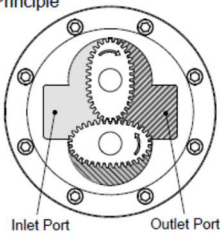

□ Liquid Entering the Measuring Chamber

▨ Liquid in Transition

▩ Liquid Leaving the Measuring Chamber

1.3 Specifications

Model Prefix	OM025	OM040	OM050
Nominal Size	1" (25mm)	1.5" (40mm)	2" (50mm)
Flow range ¹ (USG/min)	2.6 ~ 40	4 ~ 66	8 ~ 120
Flow range ¹ (L/min)	10 ~ 150	15 ~ 250	30 ~ 450
Accuracy (liquids ≥ 3cP)	± 1% of reading		
Repeatability (liquids ≥ 3cP)	Typically, ± 0.03%		
Temperature Range	-4°F ~ +176°F (-20°C ~ +80°C)		
Pressure Ratings – PSI (Bar) – threaded meters only ²			
Aluminium	580 (40)	435 (30)	285 (20)
Stainless Steel	580 (40)	435 (30)	285 (20)
Environment Protection Class (L & G Models)	IP65		
Environment Protection Class (V Models)	N/A		IP54
Flow Direction ³	Right to Left	Right to Left	Right to Left
Minimum Filtration ⁴	100 mesh (150 micron)		

1. Maximum flow rate must be reduced with increased viscosity, maintain maximum pressure drop across the meter at below 1Bar (14.5psi)
2. Flanged meter pressure rating is in accordance with applicable flange standard, or with threaded meter rating, whichever is lower.
3. Factory orientation, registers can be rotated onsite by directions in this manual
4. Filtration requirements are for soft particles only; hard particles of any size are not acceptable.

2.0 Installation

2.1 Mechanical Installation *Prior to installing the meter check :*

The fluid is compatible with the meter materials of construction using appropriate information such as fluid compatibility charts and site experience.

Application and process conditions are compatible with the meter specifications. Minimum and maximum flows are within the meter specified range including any in-situ cleaning processes. When metering viscous liquids the maximum allowable flow may need to be reduced to ensure the pressure drop across the meter does not exceed 100 kPa (1 Barg, 15 PSIG).

Process temperature and pressure does not exceed meter ratings.

The meter is not exposed to process temperatures and pressures that will cause the liquid medium to gasify (flash) within the meter.

2.1.1 Meter & totaliser orientation

The flowmeter MUST be mounted so that the rotor shafts are in a horizontal plane. This is achieved by mounting the meter so that the mechanical display is facing the user in a horizontal direction, it should never point towards the sky or towards the ground. If installed incorrectly the weight of the rotors will bear down on the lower end of the measuring

Correct Orientation



Liquid can flow into the meter from either a horizontal or vertical direction. For vertical flow installations the most common orientation is for the liquid to rise through the meter (*i.e. travel from bottom to top*) to assist in air or entrained gas elimination. Be sure to observe flow direction Arrow marking.

Given the size and weight of these meters, it is recommended that any 2" meters have adequate support so that there is no excessive pressure on the process connections. Failure to support these meters during the installation process can result in structural damage to the flowmeter's threaded connections/flanges during normal operation.

Each meter is supplied from the factory with the totaliser orientated to suit a Uni-directional horizontal pipe run, should the installation require the opposite flow direction, or have a vertical pipe run, the totaliser may be rotated in increments of 90° to suit the flow direction of the installation.

Note that the flow direction of the flowmeter is set by the flowmeter gearbox, and cannot be changed by rotating the mechanical display. The flowmeter must be installed with the correct flow orientation to suit the arrow marked on the meter, and the display rotated to allow the operator to read the digits.

In order to rotate the display follow the instructions in section 4.1 (page 8) up to the point of removing the 4 x lower housing screws. Once the 4 x lower housing screws are removed, the lower housing can be rotated in increments of 90 degrees (*the register plate does not require rotation*), and the screws reinstalled. Once the lower housing is oriented to suit your requirements, reassemble the mechanical display the opposite of disassembly, taking care that the bevel gear in the mechanical counter assembly correctly meshes with the mating bevel gear on the register plate.

2.1.2 Flow Conditioning and Locations

Strainer : It is recommended to INSTALL a 100mesh (150 micron) strainer immediately upstream of (prior to) the meter. Strainers are available from the factory.

Flow conditioning : The flowmeter does not require any flow conditioning, therefore straight pipe runs before or after the meter are not required. If required, the pipe size about the meter can be altered to suit the installation.

Locations : The flowmeter is preferred to be fitted upstream of any flow control and/or shut off valve, this prevents free discharge from the meter and minimizes the risk of drainage and air entrapment which can result in erroneous readings or damage the meter on start up.

Process or safety critical meters should be installed in a by-pass section of pipe with isolation valves to enable the meter to be isolated and serviced as required. A by-pass installation also allows purging of the system during commissioning (see *Commissioning*). The meter must be appropriately rated and is typically located downstream (on the discharge side) of the pump.

Fluid state : Fluid entering the meter must remain a liquid at all times so protect the meter to avoid solidification or gelling of the metered medium. If meters are to be trace heated or jacketed in any way the maximum temperature rating of the meter must not be exceeded. Size the meter to avoid gasification of volatiles (*flashing*) within the liquid due to the pressure drop experienced within the system or within the meter.

Hydraulic shock : If pressure surges or hydraulic shock of any kind is possible, the system upstream of the meter must be fitted with a surge suppressor or pressure relief valve to protect the meter from damage. High frequency flow pulsations can damage the meter. Such pulsations can be caused by the injection profile in diesel engines. Most pulsations are removed with the installation of a suitable pulsation dampener.

3.0 Commissioning Once the meter has been mechanically installed the meter is ready for commissioning.

The meter must NOT be run until the pipework is flushed of foreign matter, more often than not foreign matter is present after pipework fabrication or modification, weld slag, grinding dust, sealing tape & compound &/or surface rust are most common offenders.

Flushing can be undertaken by utilizing a by-pass or removing the meter from the pipework. If neither is practical then the meter rotors must be removed prior to flushing (*refer to Maintenance section of this manual for disassembly*).

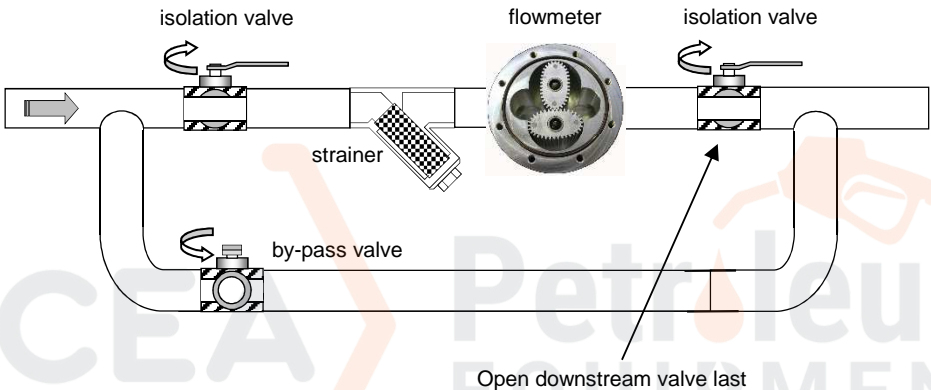

After flushing or following long periods of shutdown the meter must be purged of air/vapour. This can be achieved by allowing the liquid to flow through the meter at a slow rate until all air/vapour is displaced. Never run the meter above its maximum flow or exceed 100kpa (1 bar, 15psi) pressure drop across the meter. Now the meter is ready for its operation to be confirmed by ensuring correct indication on the mechanical display. Refer if necessary to fault finding section of this manual.

4.0 Maintenance Adhering to the installation instructions in this manual should ensure your meter provides the required operational performance. These are mechanical meters and a periodic maintenance and inspection regime will maximize the operational availability of the meter.

The frequency of maintenance depends on the application factors including liquid lubricity and abrasiveness and operational factors such as flowrate and temperature.

BEFORE undertaking meter maintenance ensure the following :

- Associated alarm(s) or control output(s) are isolated so not to affect the process.*
- The meter is isolated from any source of supply of liquid upstream or downstream.*
- The meter is depressurized and liquid drained from the meter.*

4.1 Disassembly of Meter (Refer Exploded View) To gain access to the oval geared rotors, undo the 6 body screws (5), carefully pry the meter cap from the meter body, avoiding misplacing or damaging the O-ring (3) or rotors (2).

If it is required to gain access to the internals of the mechanical register and gearbox (within meter cap [4]), you must begin with removal of the mechanical display/register.

In order to access the internal components of the mechanical register, the upper housing screws are removed (12). **Tool required: 4mm Hex Key (Allen Key)**. Once the upper housing (11) is removed, the register gasket (10) should be carefully removed and set aside, followed by the mechanical counter assembly (9). As the counter assembly is retained by the housing; once the upper housing is removed the counter assembly can be easily lifted out of the lower housing (7). When removing the mechanical counter assembly take care not to drop the input shaft or bevel gear, as these components will no longer be retained once the counter is removed from the housing.

The 4 x lower housing screws (8) can now be removed using the same **4mm Hex Key (Allen Key)**. **Do not remove the lower housing screws until your system has been turned off and depressurised; removal of these screws will allow any internal pressure in your system to blow off the lower housing and register plate assembly exposing a wetted area.**

Once the lower housing screws are removed, the lower housing (7) and register plate (6) can be removed from the flowmeter. The lower housing will come away from the flowmeter easily; however the register plate is sealed to the flowmeter with an O-Ring so may need to be pried gently off the meter cap, taking care not to damage the mounting faces.

“BEWARE THAT REMOVAL OF ITEM (6) WILL EXPOSE A WETTED CHAMBER WHICH COULD BE UNDER PRESSURE”.

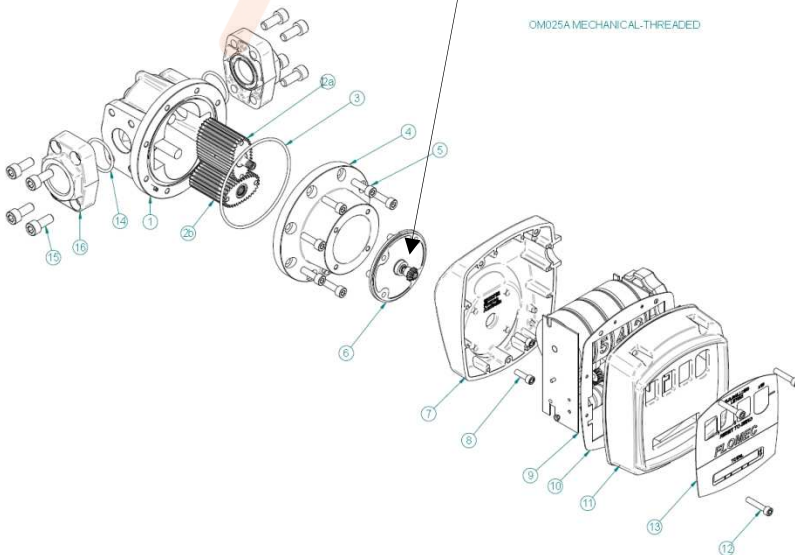

4.2 Inspection (*refer Exploded View*) Inspect O-rings for damage, chemical attack, deformity or any form. Remove, inspect & clean the rotors, check that the primary rotor gear pinion for any damage. Check the measuring chamber for damage or scoring & redress if necessary, the rotor shafts should NOT be loose or able to be rotated.

Inspect the under gears & gear shafts for any wear or damage, check that the gear train rotates freely & that the circlips are in place. Check that the transition gear shaft & bevel gear rotate freely in the register base (6).

4.3 Re-assembly of meter (*refer Exploded View*) When re-installing the rotors the primary rotor with gear pinion must be fitted to the shorter of the two rotor shafts. Both rotors will only engage correctly if fitted precisely at an orientation of 90 degrees to each other. Rotate the rotors slowly by hand to ensure they are correctly fitted at the same time check the rotor shafts & rotor bearings for wear.

Fit the O-ring into the groove and assemble the two parts of the meter, the body & cap align in one position only; this is dictated by the rotor pinion in the 1st rotor.

Fit the body cap screws (5) and tighten in a star sequence then torque in the same sequence to the torque settings stated below. All bolts should be lightly lubricated with a nickel based grease (or other suitable lubricant) prior to re-assembly.

Body Screw Torque settings:

1" (025) Meters:	10 Nm (7.5 ft.lb)
1½" (040) Meters:	20 Nm (15 ft.lb)
2" (050 & 050E) Meters:	20 Nm (15 ft.lb)

This sequence and procedure ensures the meter bodies are assembled correctly and evenly.

Fit the register assembly with maintaining original orientation if so desired.

4.4 Spare Parts

Item	Description	OM025	OM040	OM050	OM050E
		Part No.	Part No.	Part No.	Part No.
1	Body assembly with rotor shafts				
	Aluminium/Stainless Steel (for PPS and SS Rotors)	1401171	1401174	1401176	
	Stainless steel	1401110	1401112	1401135	
2#	Rotor assembly set				
	Aluminium mechanical rotor set	1524086	1524089	1524092	1524095
	PPS mechanical rotor set	1524088	1524091	1524094	
	Stainless steel mechanical rotor set	1524087	1524090	1524093	
3#	Body O-ring (O-ring size)				
	Viton (standard)	BS153V	BS245V	BS253V	BS253V
	EPR	BS153E	BS245E	BS253E	BS253E
	Teflon	BS153T	BS245T	BS253T	BS253T
	Buna-N	BS153B	BS245B	BS253B	BS253B
4	Meter cap				
	Aluminium with gear train	1402069	1402210	1402072	
	Stainless steel with gear train	1402095	1402211	1402093	
5	Body screws (Qty per meter/Price each)	8 per meter	8 per meter	8 per meter	8 per meter
	Stainless steel socket head	M6X20 SHCS 304 SS	M10X25 SHCS 304 SS	M10X25 SHCS 304 SS	M10X25 SHCS 304 SS
6	Register plate assembly				
	Aluminium - Litres - Viton	1406047	1406047	1406047	1406047
	Aluminium - US Gallons - Viton	1406046	1406046	1406046	1406046
	Stainless steel - Litres - Viton	1406048	1406048	1406048	
	Stainless steel - US Gallons - Viton	1406045	1406045	1406045	
	Stainless steel - Litres - Teflon/Kalrez	1406058	1406058	1406058	
	Stainless steel - US Gallons - Teflon/Kalrez	1406055	1406055	1406055	
7	Mechanical Register Kit				
	M3/M4 Register assembly - no fascia	1502041	1502041	1502041	1502041
	M3 FLOMEC fascia	1315109	1315109	1315110	1315110
	M4 FLOMEC fascia	1315119	1315119	1315120	1315120
	M3/M4 register reset knob kit	1506005	1506005	1506005	1506005
8	Register base screws (4 per meter)				
	Stainless steel socket head	M5X20 SHCS 304 SS	M5X20 SHCS 304 SS	M5X20 SHCS 304 SS	M5X20 SHCS 304 SS
11	Flange portion kit (incl. bolts, Viton O-rings)				
	BSP Flange Kit (Aluminium)	1522015			
	NPT Flange Kit (Aluminium)	1522016			
	BSP Flange Kit (SS)	1522017	1522021	1522025	1522025
	NPT Flange Kit (SS)	1522018	1522022	1522026	1522026
	ANSI-150 Flange Kit (SS)	1522019	1522023	1522027	1522027
	DIN PN16 Flange Kit (SS)	1522020	1522024	1522028	1522028

5.0 Fault Finding Meters have two distinct sections: the mechanical wetted section housing the rotors and reduction gear assembly & the mechanical dry section from the register base (6) out. The aim of fault finding is to trace the source of the fault to one of these two sections.

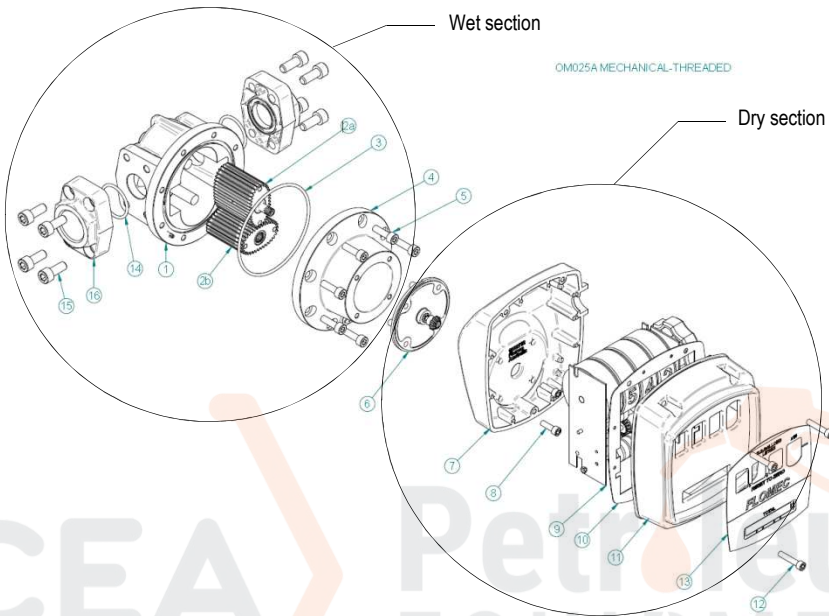

Below are basic fault finding steps. Also refer to Trouble Shooting Guide on following page.

Step 1 - Check application, installation and set-up.

Refer to Mechanical Installation section for installation and application factors that may affect the meter operation including pulsation and air entrainment or incorrect meter selection including incorrect flow rate, temperature and pressure or materials compatibility.

Step 2 - Check for blockages.

The most common cause of fault/unsatisfactory meter operation, particularly for new or altered installations, is due to blockage within the system or meter caused by foreign particles such as weld slag, sealing tape or compound, rust, etc.

Step 3 - Ensure flow is present.

No flow or lower than normal minimum flow may be attributed to a blocked strainer, jammed or damaged rotors within the flowmeter, malfunctioning pump, closed valves or low liquid level in feeder tank.

Step 4 - Ensure oval gears within meter are rotating.

If the register is not totalizing first that the rotors are rotating by holding a screw driver blade to the meter body and pressing the handle hard against the ear lobe. If necessary test the meter with the flow turned off and turned on to familiarize yourself with the audible rotation signature. If the rotors are rotating then the problem will most probably be somewhere within the reduction gear assembly (within items 4 & 6) or totaliser assembly (9).

5.1 TROUBLE SHOOTING

Symptom	Possible cause	Solution
Meter readings are high	1. Entrained air or gas	1. Remove source of air or gas entrapment 2. Install an upstream air eliminator
	2. Pulsating flow from reciprocating style pump	1. Increase back pressure on pump 2. Install a fast response one way check valve 3. Install a surge arrestor between pump & meter 4. Re-calibrate meter in situ to compensate for pulsations 5. Change pump style to smooth delivery type pump
Meter readings are low	1. Damaged or worn rotors	1. Inspect, repair, clean or replace rotors
	2. Damaged or worn measuring chamber	1. Inspect measuring chamber for damage - repair 2. Check concentricity of rotor shafts within chamber
Register no totalising	1. Rotors fouled	1. Check that rounded teeth are towards base of chamber 2. Check for obstruction due to foreign particles 3. Clean, repair or replace rotors
	2. Meter incorrectly reassembled	1. See instructions for reassembly of meter with particular emphasis on positioning of rotors & magnets
	3. Gear train jamed	1. Inspect, repair, clean or replace gear train

Notes:



**Each meter has been calibrated on mineral oil
and will contain a small amount of oil residue.**

**The oil used is Castrol Diesel Calibration
Fluid 4113 (product code 055830).**

