

ITEM NO.	ITEM DESCRIPTION
1	FILTER DONALDSON TANK BREATHER TRAP DFF0078
2	THERMAL RELIEF LINE
3	2" FIRE SAFE BALL VALVE
4	Y STRAINER - SS DN50
5	PUMP E120 240V AC PIUSI 000326000
6	POLY NOZZLE BOOT NOZZLE HOLSTER
7	WEATHERPROOF BOX
8	NOZZLE DIESEL AUTOMATIC SHUT OFF PIUSI F00610020
9	1 X 6m X 25mm Alfagomma HOSE WITH MALE BSPT FITTINGS EACH END
10	FILTER DONALDSON CLEAN AND DRY DIESEL FILTRATION P506073
11	ROAD TANKER UNLOADING
12	HOSE HOOK (OPTIONAL)
13	OUTDOOR WEATHERPROOF SINGLE PHASE POWER CONNECTION POINT
14	FMS IFUEL® LITE ONLINE
15	GAUGE PIUSI 240V OCIO F0075510D
16	PULSE METER PIUSI K600/3 F00472A00

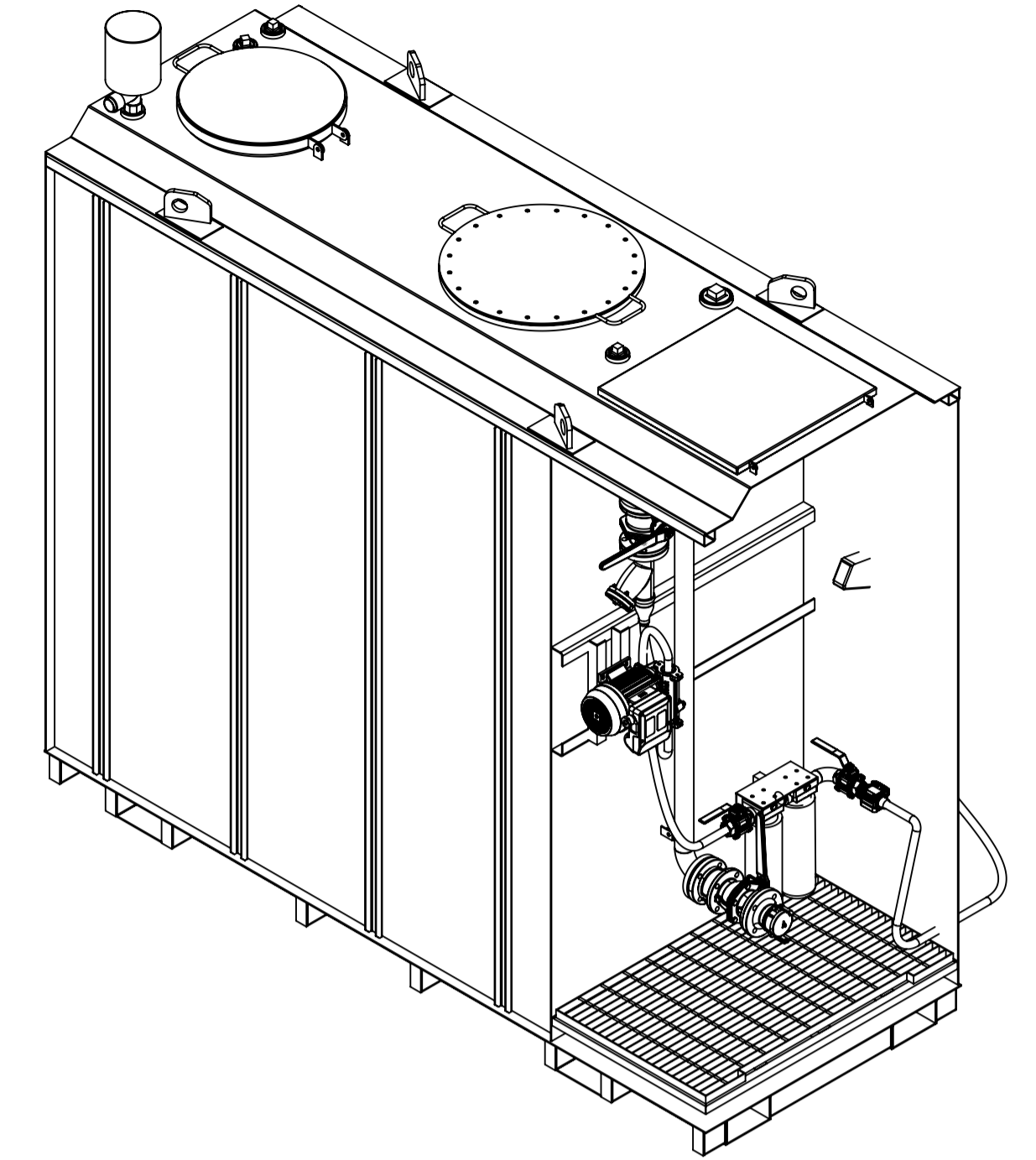

REV.	DATE	REVISION DESCRIPTION	DES. CHK.	APPROVED	REV.	DATE	REVISION DESCRIPTION	DES. CHK.	APPROVED	REFERENCE DRAWING No.	REFERENCE DRAWINGS	PRODUCED BY	DESIGNED BY	DRAWN BY	PROJECT NO	CHECK DESIGN	CHECK DRAWING	CONTRACT NO	LEAD ENGINEER	APPROVAL DATE	DRAWING SIZE	AREA PROJECT ENGINEER	ENGINEERING MANAGER	PLOT SCALE	PROJECT MANAGER	APPROVAL DATE	CAD FILE NAME	CLIENT	APPROVAL DATE	SCALE	DRAWING NUMBER	REV.
												All dimensions are in mm unless specified otherwise Drawn to AS1100.101-1992	JL	Ivo A	k	---	Ivo A	k	PIE44148	Jason L	22/11/18	A3	---	---	---	PIE44148-GOIND-PS5.5	GO IND	---		PIE44148-GOIND-PS5.5	A	

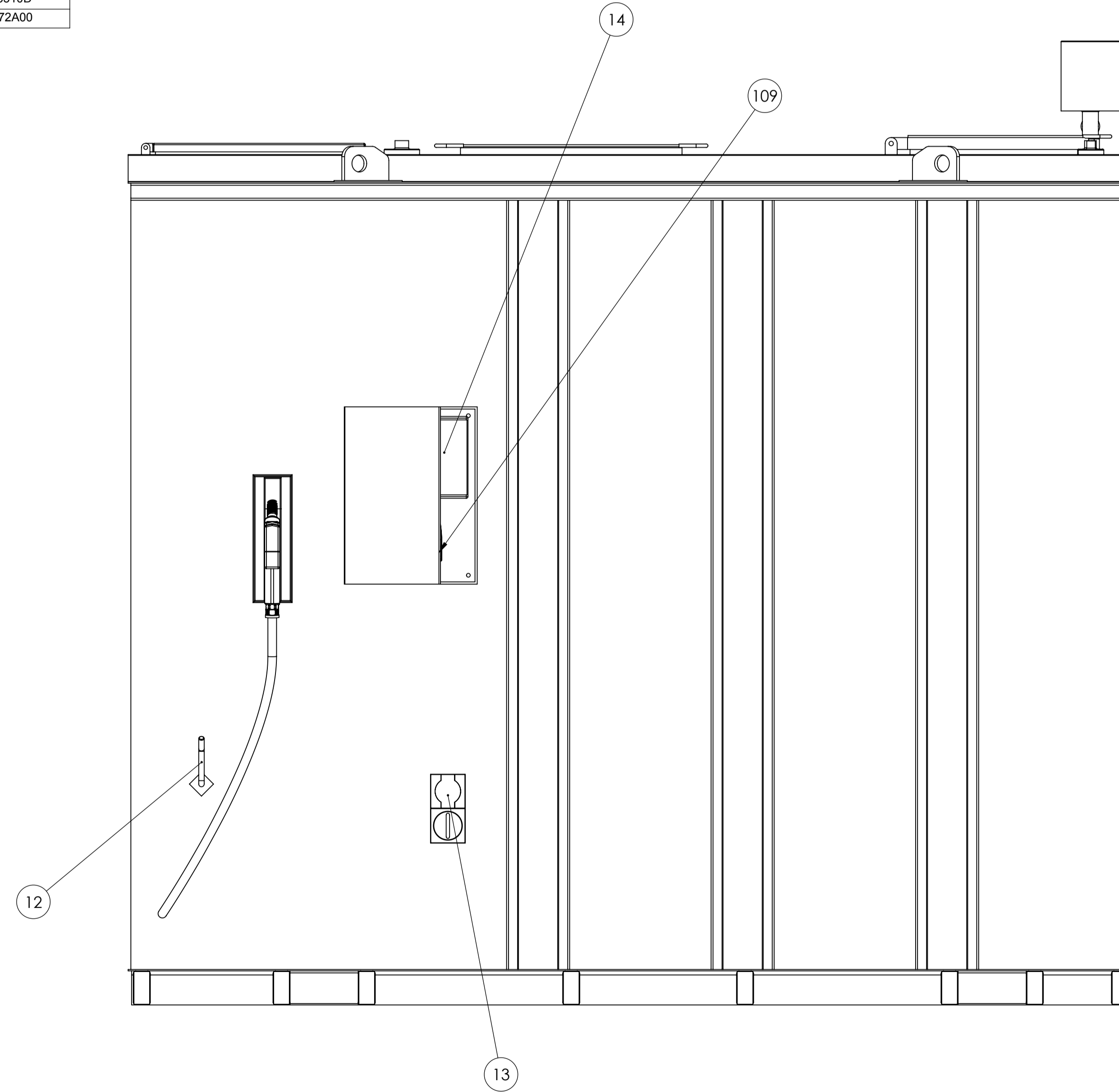
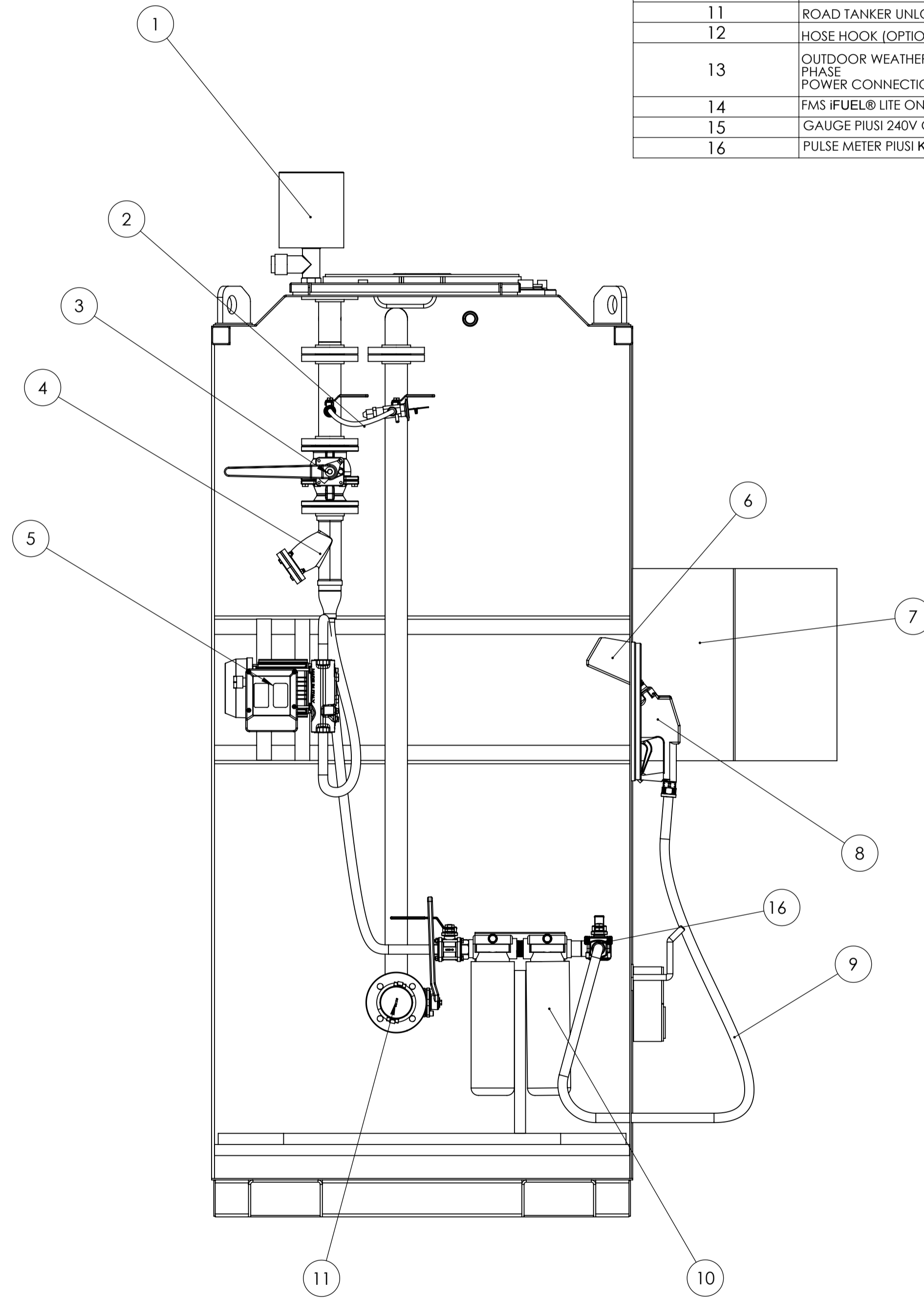