

07					
06					
05					
04					
03					
02					
01	/ /				
REV:	DATE:	REVISION:	DRAWN:	CHECKED:	APPROVED:

Note:
 > Designed and approved to AS1940 / AS1692 / AS1657
 > All welding to AS1554.1



Material:
 Weight: 4499.75KG

DRAWN: SAVING DATE: 2017/11/10
 CHECKED: DATE:
 CLIENT: DATE:
 APPROVED: DATE:

TITLE: 22000L CEA STORE
 DRAWING NO. :
 PURCHASE ORDER NO. :
 REV: A3
 SHEET: 1 of 5
 Scale: No scale

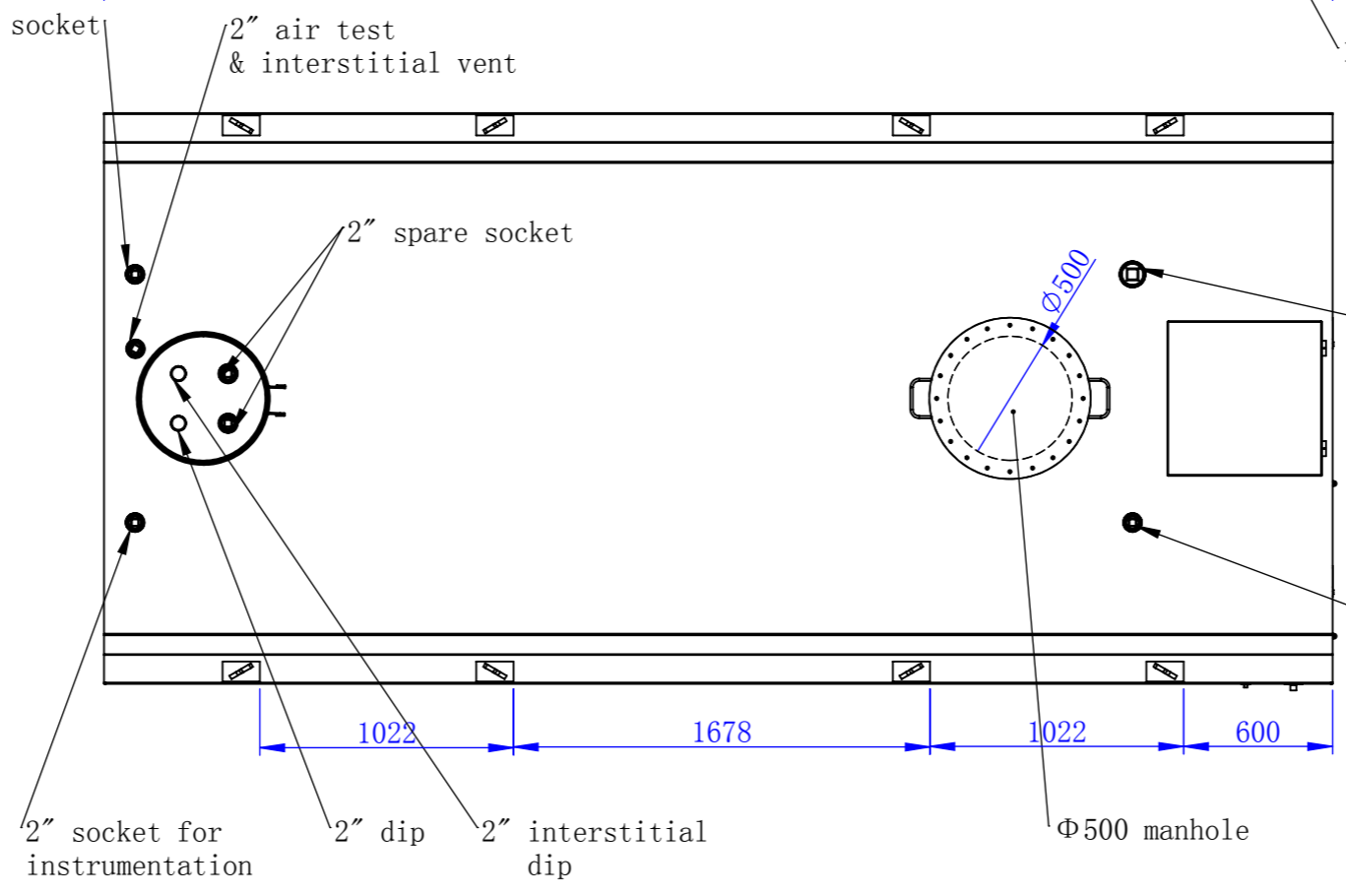
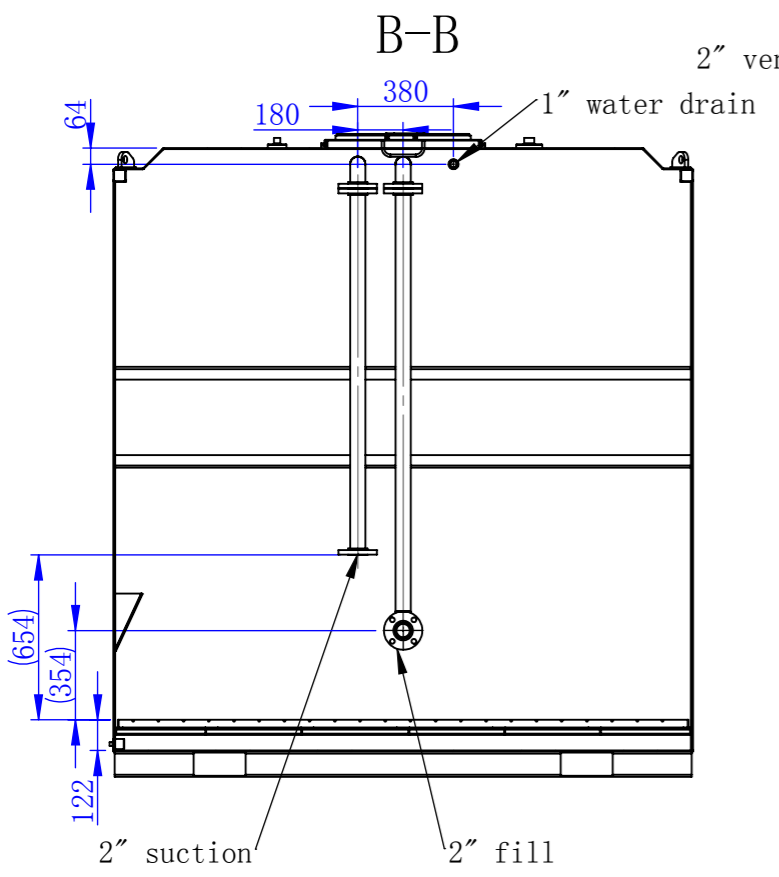
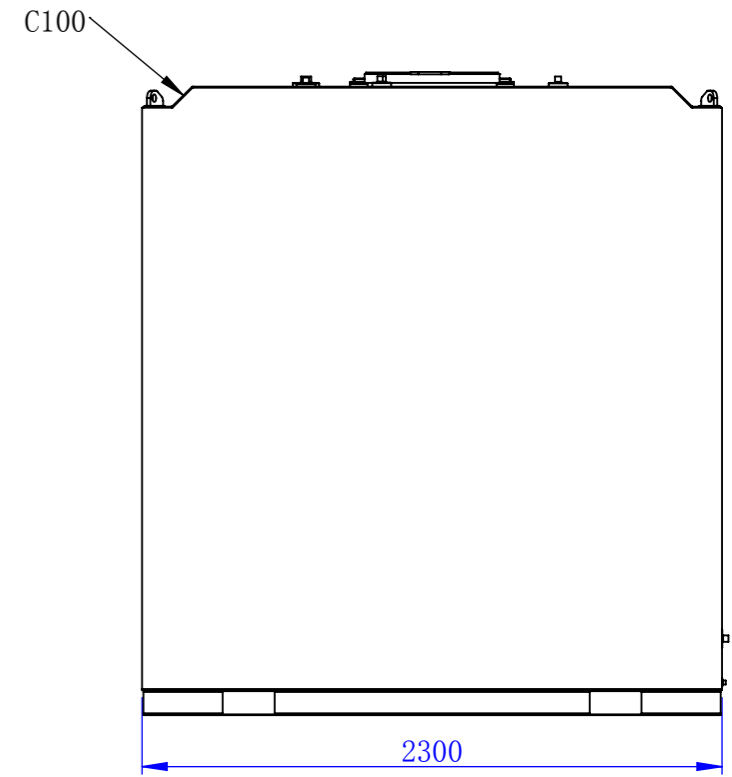
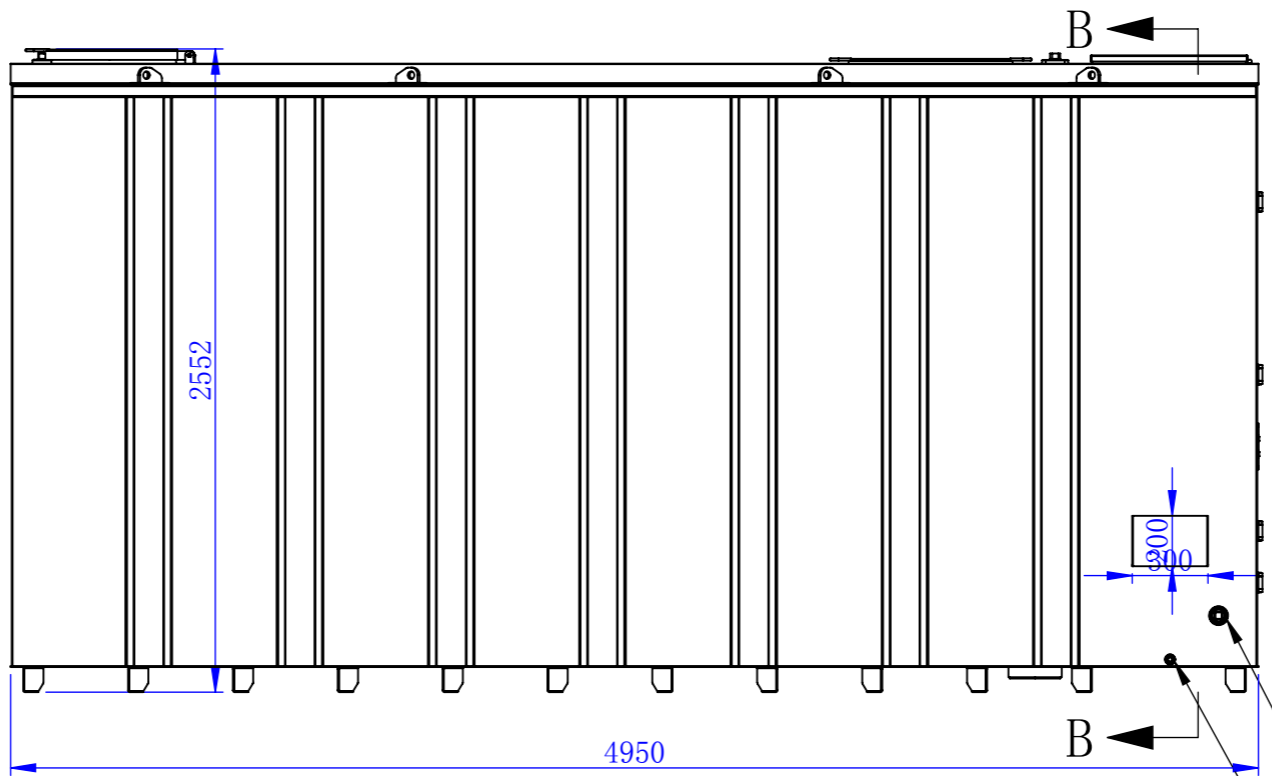
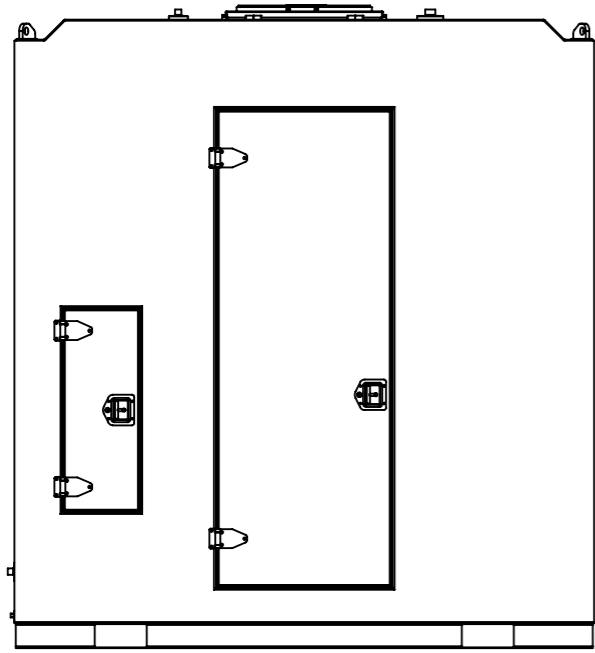

- 2" wire sokcet
- 1" drian socket
- 3" socket for submersible pump
- 2" socket for instrumentation

Tank	
Content	Diesel
External size	LWH 4950x2300x2550mm
Internal size	LWH 4230x2212x2381mm
Total volume	22000L
Safe volume (90%)	20000L

07					
06					
05					
04					
03					
02					
01					
REV:	DATE:	REVISION:	DRAWN:	CHECKED:	APPROVED:



Material:
Weight: 4499.75KG

DRAWN: SAVING DATE: 2017/11/10
 CHECKED: DATE:
 CLIENT: DATE:
 APPROVED: DATE:

22000L CEA STORE

DRAWING NO. :
 REV: A3
 SHEET: 2 of 5
 PURCHASE ORDER NO. :
 Scale: No scale

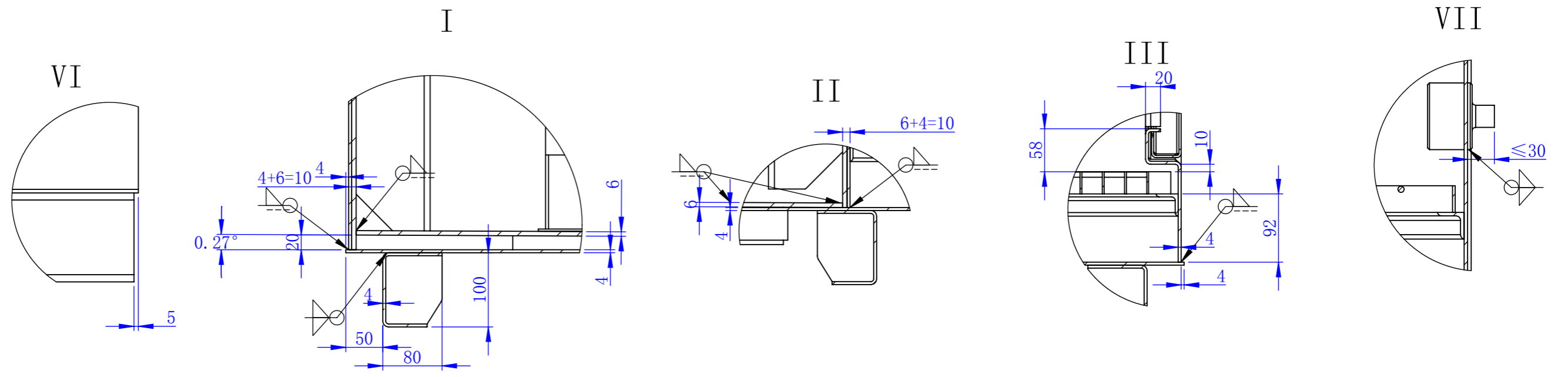
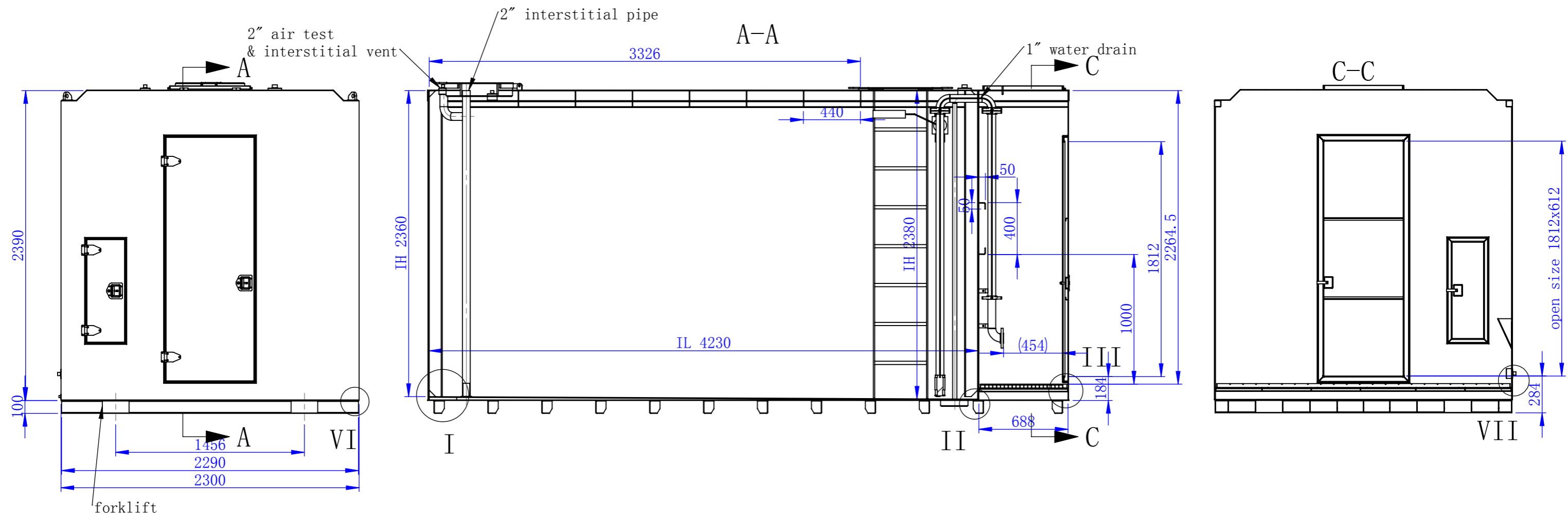

07					
06					
05					
04					
03					
02					
01					
REV:	DATE:	REVISION:	DRAWN:	CHECKED:	APPROVED:

CEA Petroleum
EQUIPMENT

Material:	
Weight:	4499.75KG

DRAWN:	SAVING DATE:	TITLE:	
CHECKED:	DATE:	22000L CEA STORE	
CLIENT:	DATE:	DRAWING NO. :	REV:
APPROVED:	DATE:	PURCHASE ORDER NO. :	A3
		Scale:	⊕ - ▽
		No scale	

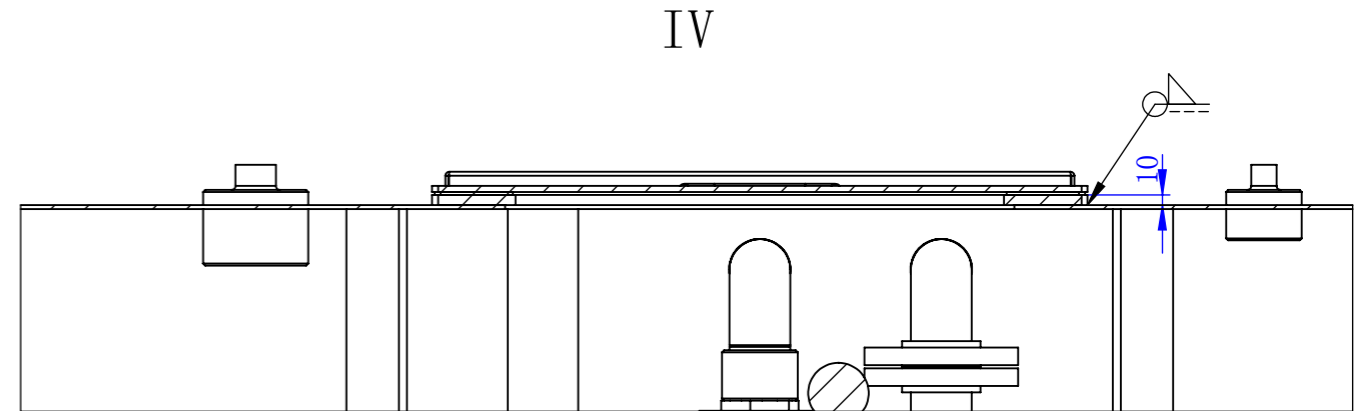
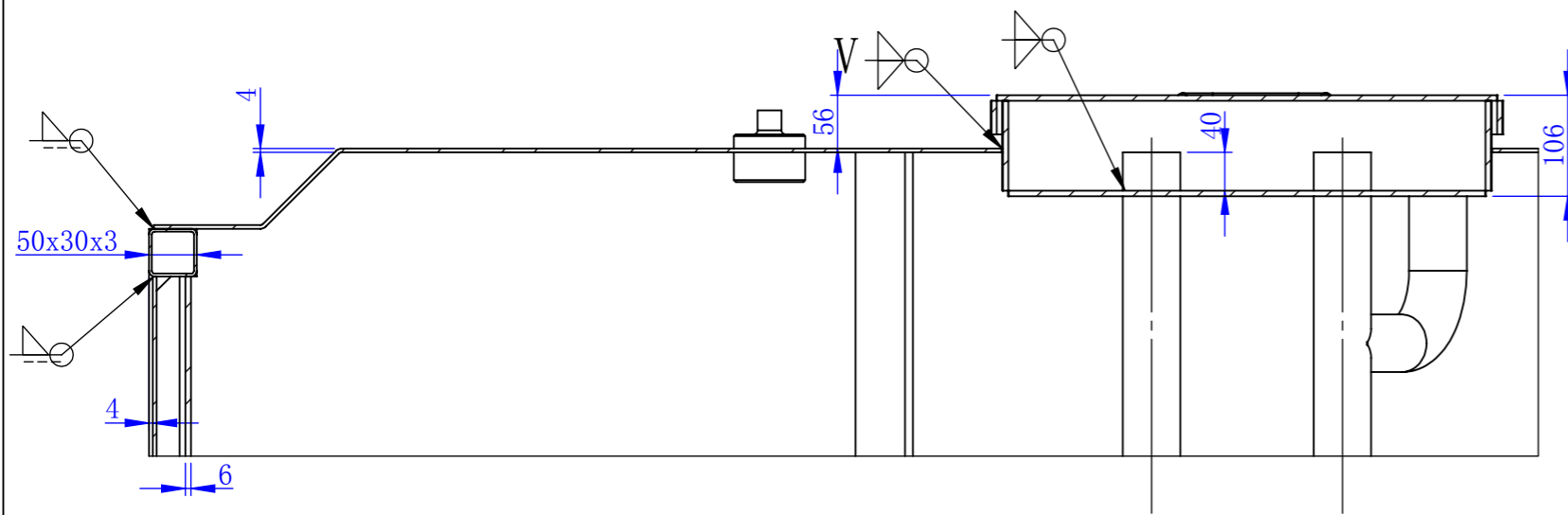
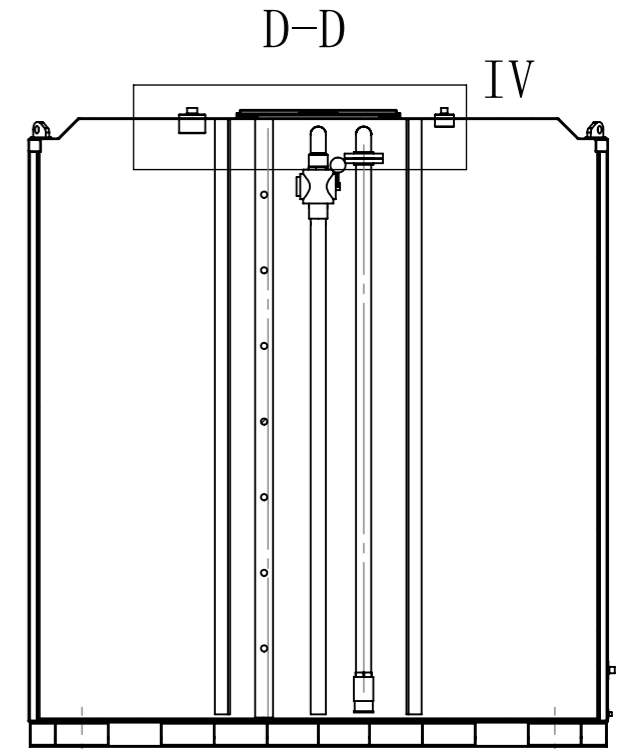
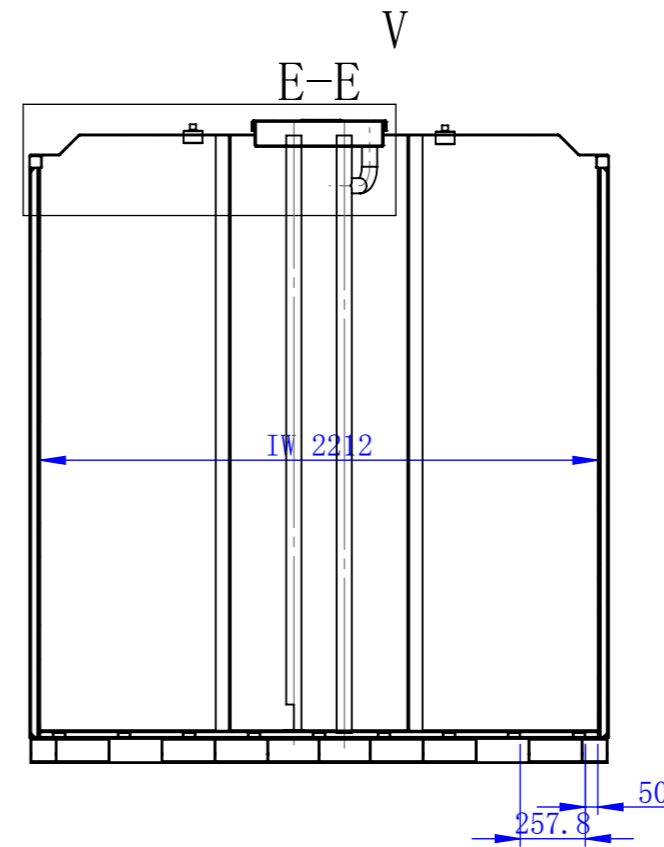
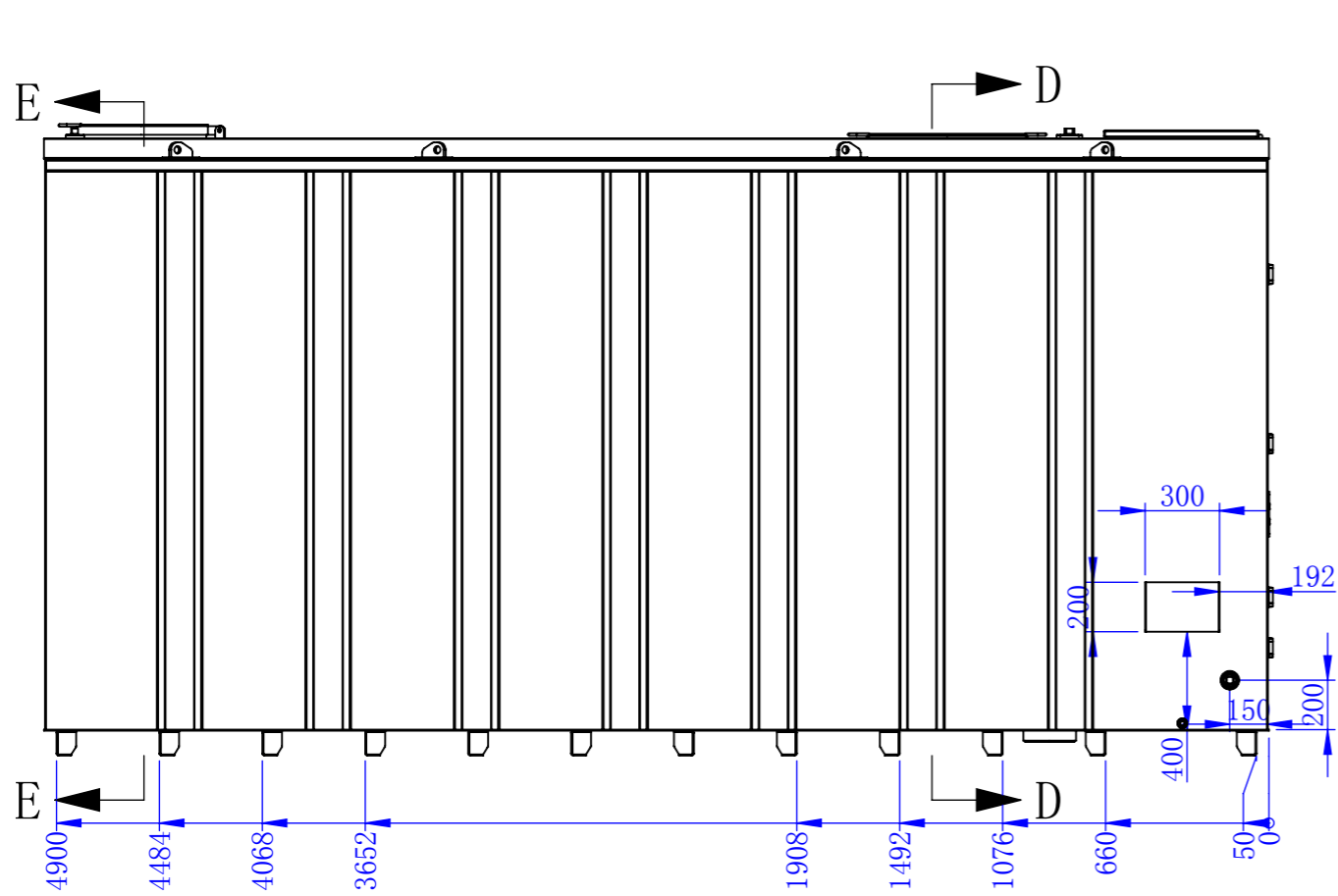

07					
06					
05					
04					
03					
02					
01					
REV:	DATE:	REVISION:	DRAWN:	CHECKED:	APPROVED:



Material:
Weight: 4499.75KG

DRAWN:
CHECKED:
CLIENT:
APPROVED:

SAVING DATE:
DATE:
DATE:
DATE:

22000L CEA STORE
DRAWING NO. :
PURCHASE ORDER NO. :
REV:
SHEET: 4 of 5
Scale: No scale

A3



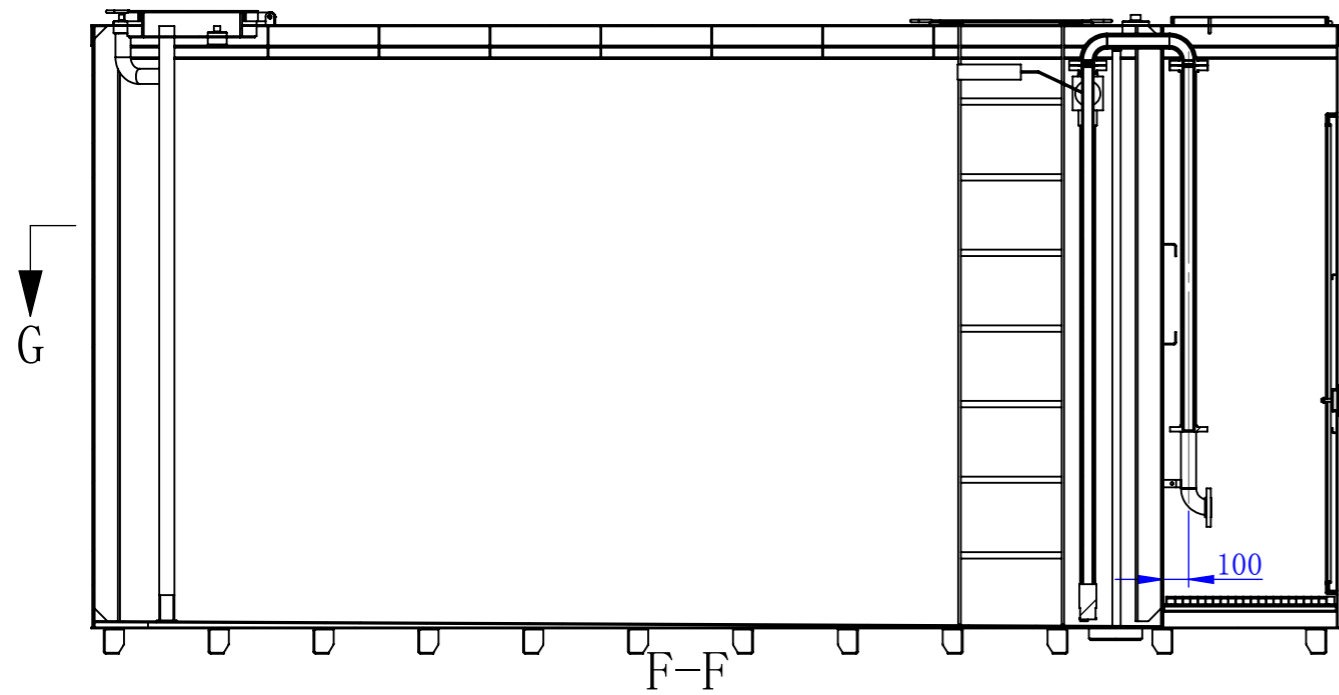
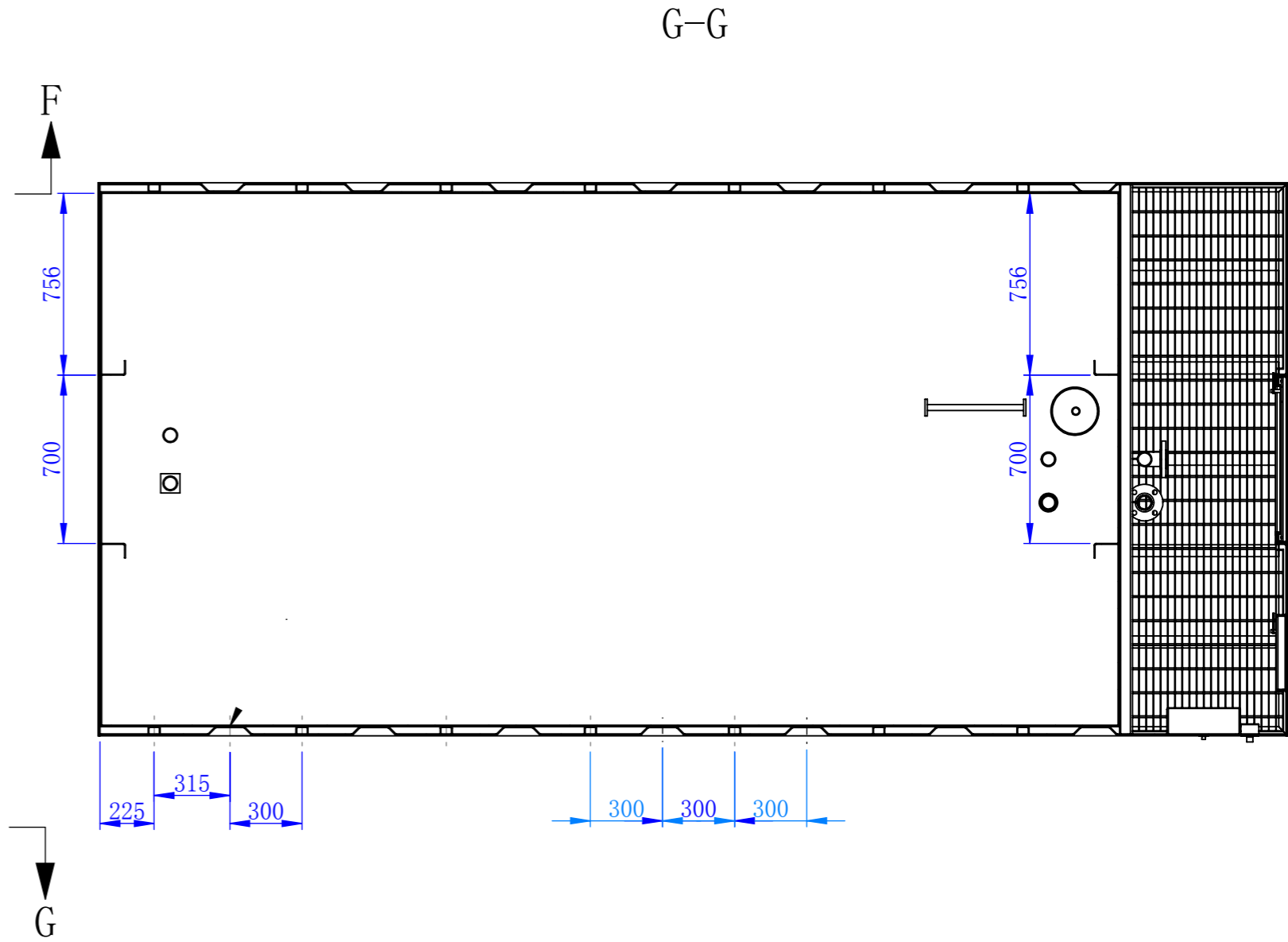
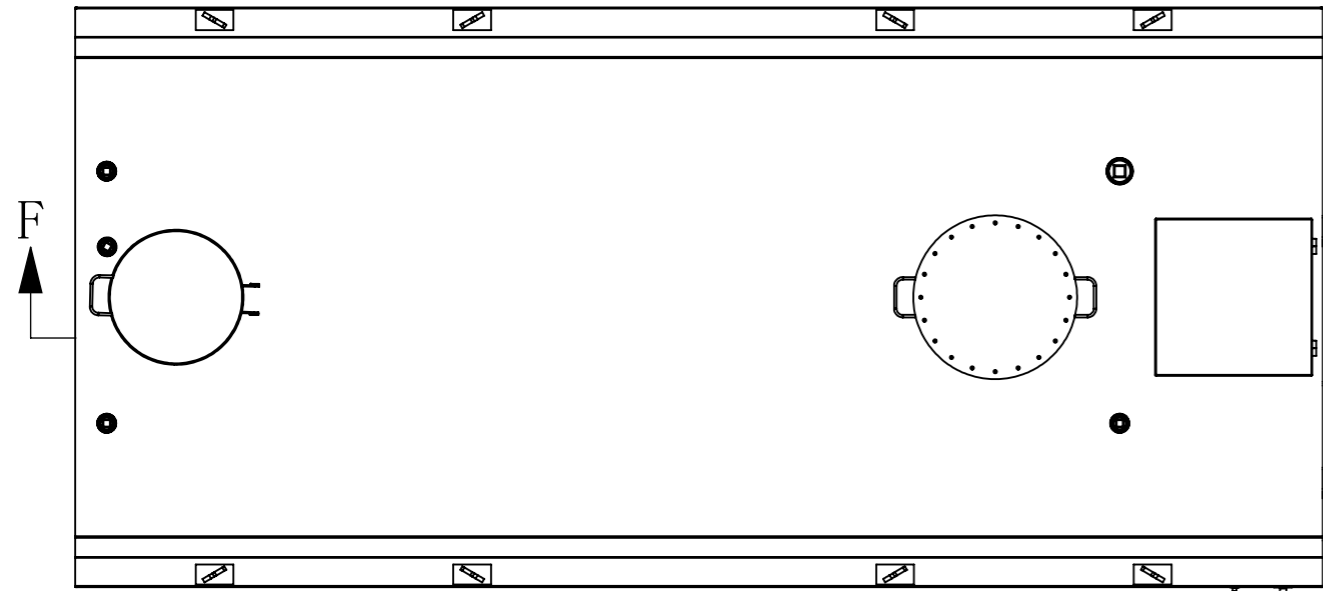

07					
06					
05					
04					
03					
02					
01					
REV:	DATE:	REVISION:	DRAWN:	CHECKED:	APPROVED:



Material:
Weight: 4499.75KG

DRAWN:
CHECKED:
CLIENT:
APPROVED:

SAVING DATE: 2017/11/10
DATE:
DATE:
DATE:

TITLE:
22000L CEA STORE

DRAWING NO. :

PURCHASE ORDER NO. :

REV:

SHEET:
5 of 5

Scale:
No scale

A3

