



**Petroleum
EQUIPMENT**



TECH FLOW 3C/4C MAT FLOW 3C/4C R-FLOW 3C/4C

ITALIANO
(lingua originale)

IT

ENGLISH
(translation of original instructions)

EN





USE AND MAINTENANCE MANUAL

Machine: DIESEL FUEL METERS

Models: TECH FLOW 3C-4C, MAT FLOW 3C-4C, R-FLOW 3C-4C



The use and maintenance manual must be carefully stored near the machine in an environment protected against humidity and heat. The manual must accompany the machine if sold. It is prohibited to damage, modify or remove any part of the manual.

The undersigned:

ADAM PUMPS S.p.a. Soc. con Socio Unico

Via della Resistenza, 46/48

41011, Campogalliano (MO), ITALY

DECLARES

that the equipment described:

Description: mechanical Meter

Models: TECH FLOW, MAT FLOW, R-FLOW

Year of manufacture: see the production date on the label affixed to the product

MFG DATE:

Month

Feb-17

Year

It is subjected to the following checks and calibrations: factory calibration, leak test, functional check.

This declaration does not exempt the installer or user from carrying out the appropriate checks and calibration to obtain the declared precision $\pm 1\%$ when testing the system.

ADAM PUMPS reserves the right to change the testing process described at any time and without prior notification.

Device not suitable for measuring products for sale to the public, their use in relation to third parties is prohibited

The documentation is available to the relevant authority, against a justified request, from ADAM PUMPS S.p.a. Soc. con Socio Unico or by sending a request to: info@adampumps.com

The person authorised to compile the technical file and draw up the declaration is Davide Stassi as legal representative

Place and date of the document
Campogalliano, 28/05/2020

The legal representative

Davide Stassi

TABLE OF CONTENTS

1 - GENERAL WARNINGS

2 - SAFETY INSTRUCTIONS

2.1 Safety measures

2.2 First aid

2.3 Protective devices

2.4 Packaging

2.5 Contents

3 - OPERATING CONDITIONS

Environmental conditions

3.2 Allowed fluids / Forbidden fluids

3.3 Meter orientation

4 - INSTALLATION

4.1 General information

4.2 Mechanical

5 - CALIBRATION

5.1 Definitions

5.2 Calibration procedure

6 - TROUBLESHOOTING

7 - MAINTENANCE

7.1 Cleaning

8 - DEMOLITION AND DISPOSAL

9 - WARRANTY

10 - TECHNICAL SUPPORT

1 - GENERAL WARNINGS

! ***IMPORTANT:** It is essential to have understood the entire instruction manual before performing any operation so as to safeguard the operator and to avoid potential product damage.*

Storing the manual: This manual must be kept intact and fully legible. The end user and the skilled technicians authorised with installation and maintenance of the product in question must be able to consult it at all times.

Reproduction rights: This manual is the property of ADAM PUMPS S.p.a. Soc. con Socio Unico, which is the sole owner of all rights provided for by applicable law, including without limitation copyright rules. All rights under these rules belong to ADAM PUMPS S.p.a. Soc. con Socio Unico: reproduction, even partial, of this manual, its publication, modification, transcription, public disclosure, distribution, marketing in any form, translation and/or development, loan, or any other activity reserved by law to ADAM PUMPS S.p.a. Soc. con Socio Unico

2 - SAFETY

2.1 - Safety Measures

! ***CAUTION: Live equipment.** Contact between the power supply and the liquid to be pumped must be prevented at all costs. Connect all equipment in the work area to the earthing system. Immediately stop operation in the event of electrostatic discharges or if you feel a shock. Do not use this device until the problem has been identified and duly solved.*

! ***CAUTION: Flammable liquids.** Observe the precautions against the risk of fire or explosion. Read the safety data sheets to know the specific hazards of the fluids used. If there are flammable liquids in the work area (petrol, glass cleaning liquids, etc.), you must be aware that the vapours produced can ignite and explode. Only use the product in well-ventilated areas to prevent fires and explosions. Do not connect or disconnect the power cables or turn the lights on and off in the presence of flammable vapours.*

! ***CAUTION: Dangerous liquids.** Read the safety data sheets to know the specific hazards of the fluids used. When pouring dangerous liquids, always follow the safety measures provided by the liquid manufacturer. Keep dangerous liquids in approved containers and dispose of them in compliance with the applicable guidelines.*

IMPROPER USE OF THE PRODUCT

Improper use can result in serious injury or death. Do not operate the unit when fatigued or under the influence of alcohol or drugs. Do not leave the work area while the product is powered or under pressure.

Turn all equipment off when not in use. Do not blow compressed air through the meter. Prevent liquids from drying inside the meter. Do not alter or modify the product. Alterations or modifications to the product may invalidate the approvals and cause safety hazards. Place the pipes and cables away from traffic, sharp edges, moving parts, and hot surfaces. Do not twist or bend the hoses too much, do not move the product by the hoses. Keep children and animals away from the work area. Observe all of the safety regulations in force.

ALWAYS KEEP A WORKING FIRE EXTINGUISHER IN THE WORK AREA.

2.2 - First Aid

In the event of contact with EYES, SKIN, INHALATION or INGESTION, read the SAFETY DATA SHEET of the fluid used.

2.3 - Technical specifications

Protective equipment characteristics: Wear equipment that is appropriate for the operations to be carried out; Wear equipment that is resistant to the products used. **Personal Protective Equipment to be worn:**



Safety footwear



Protective clothing



Protective gloves



Safety goggles

2.4 - Packaging

The meter is supplied in a box bearing a label with the following data:

- Product
- Product version
- Flow direction of the fluid (Up, Down, Right, Left)
- Gross weight

2.5 - Contents

QTY	COMPONENT
1	TECH-FLOW, MAT-FLOW, R-FLOW
1	USE AND MAINTENANCE MANUAL

3 - OPERATING CONDITIONS

3.1 Environmental conditions

Temperature: min. -10°C / max. +60°C (*)

Relative humidity: max. 90%

(* *Caution!* The temperature limits shown refer to the components making up the meter and should be respected to prevent any damages or malfunctions from occurring.

3.2 - Allowed fluids forbidden fluids

Allowed

DIESEL FUEL with 2 to 5.5 cSt viscosity (at 38°C)

Minimum flash point (MF): 55 °C

LIGHT OIL with 10 to 200 cSt viscosity (at 40°C)

Forbidden

petrol, flammable liquids (mf <55°C), food liquids, solvents, liquids with > 200 cst viscosity, water, corrosive chemicals

3.3 - Meter orientation

For proper use, install the TECH-FLOW, MAT-FLOW or R-FLOW meter as instructed on the back (fluid direction arrow).

The meters can have fluid outlet upwards, downwards, to the left or to the right.

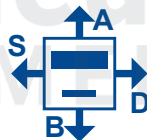

4 - GENERAL INDICATIONS

4.1 - General Information

TECH-FLOW, MAT-FLOW, R-FLOW meters have 1" BSP-G threaded inlets and outlets that are flanged on both sides. The meter is designed for fixed installation on a line.

! *IMPORTANT:* Do not use conical connections that can damage the meter. When installing position a suction filter of at least 40 mesh.

4.2 - Mechanical meters

TECH-FLOW, MAT-FLOW, R-FLOW mechanical meters can have a 3-digit or 4-digit numerator, depending on the version chosen. The meter is delivered pre-calibrated by the manufacturer and ready for installation.

! *IMPORTANT:* Due to the different operating conditions, pre-calibration may be different than the one required; it is therefore recommended to calibrate the meter with each installation (see CHAP. 5).

5 - CALIBRATION

5.1 - Fluid

Fluid litres = Fluid weighed ÷ Fluid density

Flow rate (in litres per minute, LPM) = Fluid litres ÷ Fluid dispensing time (in seconds) · 60

5.2 - Calibration Procedure

Calibration procedure for mechanical TECH-FLOW, MAT-FLOW, R-FLOW meters:

Fill the container up to a measured quantity.

If the amount displayed does not match the measured quantity, the meter must be calibrated. Make sure the pump is off and the system is not under pressure before moving onto the next point.

Remove the sealing plug and turn the calibration screw anticlockwise to reduce the quantity displayed or clockwise to increase it (a full turn changes the quantity displayed by about 2 litres).

Put the sealing plug back.

Repeat the previous points until calibration is acceptable.



! CAUTION: if the amount of liquid dispensed is less than 5 litres, the device will not allow calibration.

6 - TROUBLESHOOTING

PROBLEMS:	POSSIBLE CAUSES:	SOLUTIONS:
The meter does not read	Suction filter clogged	Clean the filter
	Meter placed incorrectly	Check the direction arrow of the liquid on the body; if the meter has been installed upside down it won't work
Incorrect reading precision	Flow rate too low or too high	check the technical specifications for the flow rate limits (Chap. 12.2)
	Incorrect calibration	Follow the procedure for a new calibration (Chap. 6.2)
	Air inside the system	Check for any air intake leaks and make sure the pump does not draw in air

7 - MAINTENANCE

7.1 - Cleaning

TECH-FLOW, MAT-FLOW, R-FLOW meters do not have a suction filter. It is advisable to add a suction filter of at least 40 mesh to prevent any residues from interfering with the mechanical parts measuring the fluid. To clean the filter, see the instruction manual provided with the filter used.

9 - DEMOLITION AND DISPOSAL

9.1 - Disposal Instructions

If the meter is to be scrapped, its parts are to be given to companies specialised in disposing of and recycling industrial waste, as shown on the table below:

PARTS TO BE DISPOSED OF	DISPOSAL METHOD
PACKAGING	The packaging consists of biodegradable cardboard which can be sent to companies for normal pulp recycling.
METAL PARTS	The metal parts, whether painted or aluminium and stainless steel, are usually recycled by companies specialised in the scrap metal industry.
PARTS OF A DIFFERENT NATURE	Other parts of the system in which the meter is installed, such as pipes, rubber gaskets, plastic parts and wiring, are to be given to companies specialised in disposing of industrial waste.
APPLICABLE REGULATIONS FOR CUSTOMERS IN THE EUROPEAN UNION	The European Directive 2002/96/EC states that the equipment bearing this symbol on the product and/or on the packaging is not to be disposed of with unsorted municipal waste. The symbol indicates that this product must not be disposed of with normal household waste. It is the responsibility of the owner to dispose of these products and the other electrical and electronic equipment through specific collection facilities appointed by the government or by local authorities.



10 - WARRANTY

The warranty provided by the manufacturer Adam Pumps Spa covers the product for 2 years from the date of production.

Adam Pumps Spa (manufacturer) provides its customers with:

a warranty that covers problems resulting from production and conformity defects in the purchased products

the warranty period starts from the date indicated on the CE label which indicates the date of manufacture. A label indicating the date of manufacture will be applied to those products which are not provided with a CE label. Therefore, the warranty period will start from that date;

the warranty will become immediately null and void should the date of manufacture be illegible, for any reason, unless Adam Pumps Spa is responsible for this;

the warranty covers repairs or replacement of the product, in the event it cannot be repaired

repair operations can be carried out only by Adam Pumps or by Adam Pumps' authorised centres;

the warranty will not be valid in the event the product is tampered with by unauthorised persons, bodies, and/or companies;

any warranty request is subject to approval by Adam Pumps. The goods can be returned only if provided with an authorisation code. Upon request, Adam Pumps will provide this code which will invoke the warranty for the product to be repaired or replaced

unless otherwise agreed with Adam Pumps, the returned goods must be sent via transport pre-paid by who has invoked the warranty to Adam Pumps Spa;

goods returned without authorisation and/or with transport not paid can be rejected;

The warranty will not be applied in the following cases:

Failure to use or install the product according to Adam Pumps' instructions

The product has been used with unauthorised fluids.

The product has been modified or tampered with

The product is used in an area with power supply defects (voltage changes, current phase shift, etc.)

The product is used without the supplied suction filter (inside or outside the pump).

Immediately excluded from the warranty are: adhesive labels, plastic and metal casing, keyboards and masks, components subject to wear such as blades, impellers, graphite brushes (where present in the motors), seals and gaskets in general.

11 - TECHNICAL SUPPORT

The Manufacturer is always available for any information required on installation, operation or maintenance of the machine. The Customer should ask the questions clearly, with reference made to this Manual and to the instructions listed. Always remember to specify the type of product.

Technical Specifications

SPECIFICATIONS	TECH FLOW 3C MAT FLOW 3C	TECH FLOW 4C MAT FLOW 4C	R-FLOW 3C	R-FLOW 4C
Measuring system:	Swinging plate	Swinging plate	Swinging plate	Swinging plate
Degree of protection:	IP55	IP55	IP55	IP55
Partial [digits]:	3	4	3	4
Totaliser [digits]:	6	8	6	8
Unit of measurement:	litres, gallons*	litres, gallons*	litres, gallons*	litres, gallons*
Min flow rate [l/min / GPM]:	20 / 5,28	20 / 5,28	20 / 5,28	20 / 5,28
Max flow rate [l/min/ GPM]:	120 / 31,7	120 / 31,7	120 / 31,7	120 / 31,7
Max pressure [bar/psi]:	3,5/50	3,5/50	10/145	10/145
Burst pressure [bar/psi]:	25/362	25/362	30/435	30/435
Precision [%]:	± 1	± 1	± 1	± 1
Repeatability [%]:	0,2	0,2	0,2	0,2
Input/Output [BSP/G]:	1" F, Flanged	1" F, Flanged	1" F, Flanged	1" F, Flanged
Body material:	Aluminium	Aluminium	Aluminium	Aluminium
Swinging plate material:	POM-C	POM-C	PBT	PBT
O-Ring material:	NBR	NBR	NBR	NBR
Other materials in contact with the fluid:	Brass, PPS, Steel		Brass, Steel	
Min/max operating temperature [°C]:	-10 / +60	-10 / +60	-10 / +60	-10 / +60
Allowed fluids:	Diesel, Light oil		Diesel	
Forbidden fluids:	Gas, Alcohol, Petrol, Water			
Noise [dBA]:	< 75	< 75	< 75	< 75
Net weight [Kg]:	1,9	1,9	1,9	1,9
Single size packaging [mm]:	I 220 x b 150 x h 220			
Gross weight [Kg]:	2,2	2,2	2,2	2,2

EXPLODED VIEWS

TECH FLOW 3C-4C

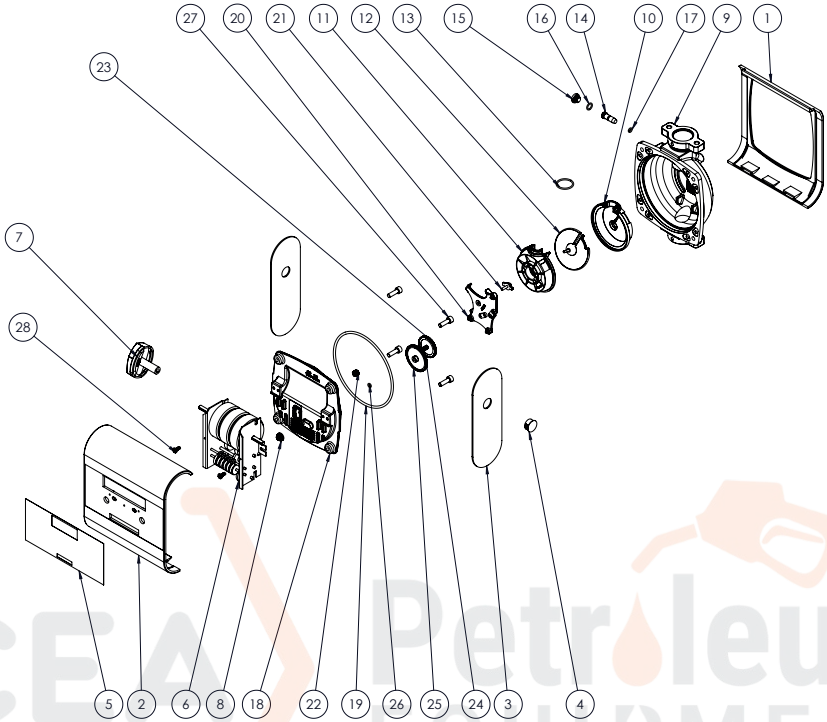

3C	DESCRIPTION	Q.TY	
1	TF014N	BOTTOM COVER	1
2	TF013N	TOP COVER	1
3	TF015G	SIDE COVER WITH HOLE	2
4	60302000	PLASTIC CAP	1
5	MA999	FACEPLATE	1
6	TF044	MECHANICAL NUMERATOR	1
7	TF012X	RESET KNOB	1
8	TF005	CONICAL GEAR	1
9	TF011	METER BODY	1
10	TF002	BOTTOM HALF-CHAMBER	1
11	TF003	TOP HALF-CHAMBER	1
12	TF001	SWINGING PLATE	1
13	OR001	O-RING Ø24 X 2	1
14	TF019	CALIBRATION SCREW 1/8"	1

3C	DESCRIPTION	Q.TY	
15	TF018	CALIBRATION CAP 1/8"	1
16	11010100200	O-RING 108 NBR	1
17	11010050200	O-RING 2018 NBR	1
18	TF010	METER FLANGE	1
19	OR002	O-RING 4500	1
20	TF009	GEAR SUPPORT	1
21	TF008	PIN WITH LEVER	1
22	TF004	CYLINDRICAL GEAR	1
23	6051800000	ROLLER Ø2	1
24	TF006	DOUBLE GEAR WHEEL Ø36	1
25	TF007	GEAR WHEEL Ø45	1
26	11010040200	O-RING 2015 NBR	1
27	VT001	SCREW M6X20	4
28	80901439100	SCREW M4X10	2

4C	DESCRIPTION	QTY	
5	MA998	FACEPLATE	1
6	TF045	MECHANICAL NUMERATOR	1

MAT FLOW 3C - 4C

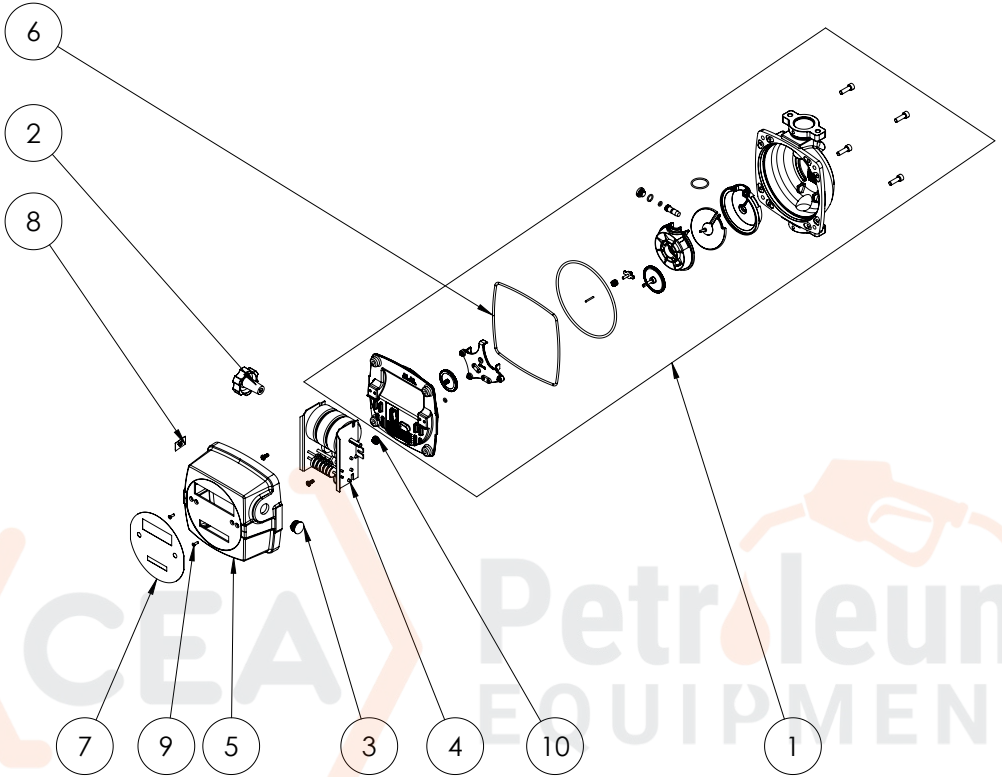

	3C	4C	DESCRIPTION	QTY
1	PHANTOM3	PHANTOM4	3/4DIGIT MAT FLOW	1
2	TF063	TF063	RESET KNOB	1
3	60302000	60302000	RESET CAP	1
4	TF044	TF045	NUMERATOR HEAD	1
5	TF069	TF069	MAT-FLOW COVER	1
6	OR040	OR040	O-RING 130x3 NBR 70	1
7	MA984	MA983	FACEPLATE	1
8	MA071	MA071	"MADE IN ITALY" LABEL	1
9	13101006	13101006	SCREW M3x10 ISO7046	2
10	TF005	TF005	CONICAL GEAR	1

R-FLOW 3C - 4C

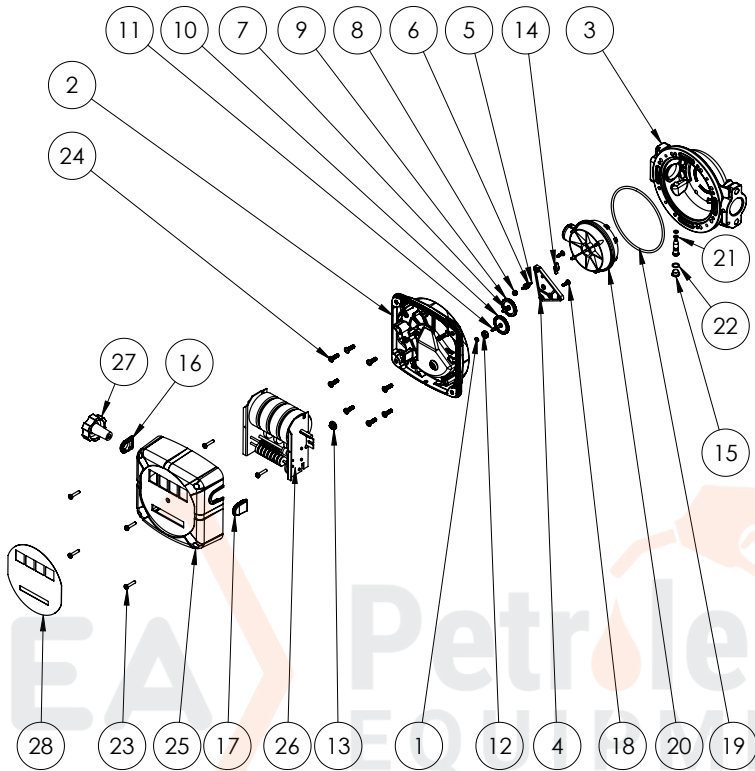

4C	DESCRIPTION	Q.TY
1	OR051 QUAD-RING (3,68x1,78) FKM 70SH	1
2	TF095 CHAMBER LID	1
3	TF097 METER BODY	1
4	TF098 GEAR HOLDER	1
5	TF099 GEAR WHEEL SHAFT Z.14	1
6	TF100 GEAR WHEEL Z14	1
7	TF101 WHEEL GEAR SHAFT Z .61/11 Z.61/23	1
8	TF102 SHAFT BUSHING Ø3MM	1
9	TF103 GEAR WHEEL Z61-Z11	1
10	TF104 GEAR WHEEL Z62	1
11	TF105 CONIC PINION SHAFT	1
12	TF106 BUSHING CONIC SHAFT	1
13	TF107 CONIC PINION Z14	1
14	TF108 DRAG LEVER	1

4C	DESCRIPTION	Q.TY
15	TF110 BYPASS CLOSING CAP + O-RING	1
16	TF111 HOLED COVER CAP	1
17	TF112 CAP COVER	1
18	VT048 SCREW TC 3,5X12 UNI8112	2
19	OR045 O-Ring 4500 NBR	1
20	TF096 MEASURE CHAMBER	1
21	TF109 ADJUSTMENT BY-PASS SCREW +O-RING	1
22	11010100200 O-Ring 108 NBR	1
23	VT071 SCREW TC M4x20 8.8 UNI8112	6
24	VT040 SCREW TC CROSS M5x16	8
25	TF091 METER COVER	1
26	TF045 4C DIGITS HEAD LITERS	1
27	TF063 MAT FLOW RESET KNOB	1
28	MA147 4C LABEL	1

3C	DESCRIPTION	Q.TY
26	TF044 3C DIGITS HEAD LITERS	1
28	MA146 3C LABEL	1

OVERALL DIMENSIONS

TECH FLOW

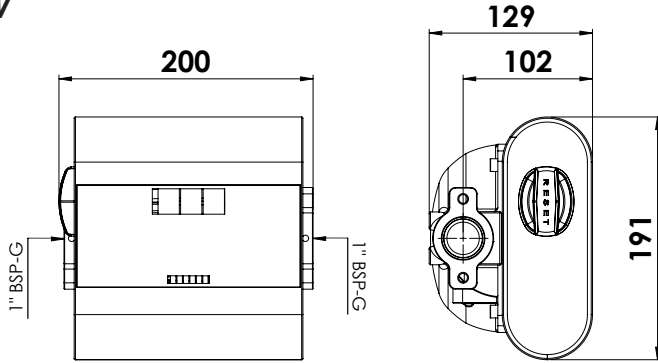

MAT FLOW

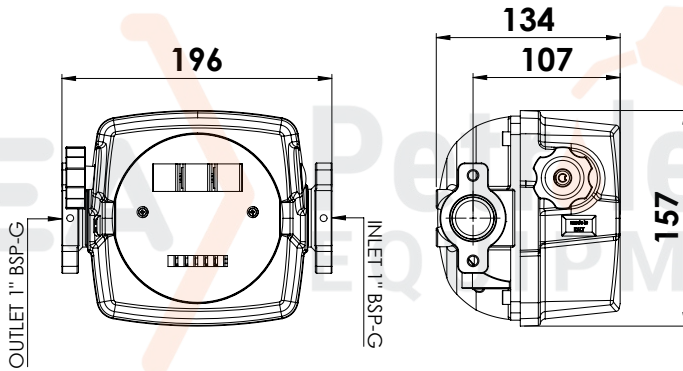

R-FLOW

