

T4000 Wiring Diagram Setting for Day Tank Control

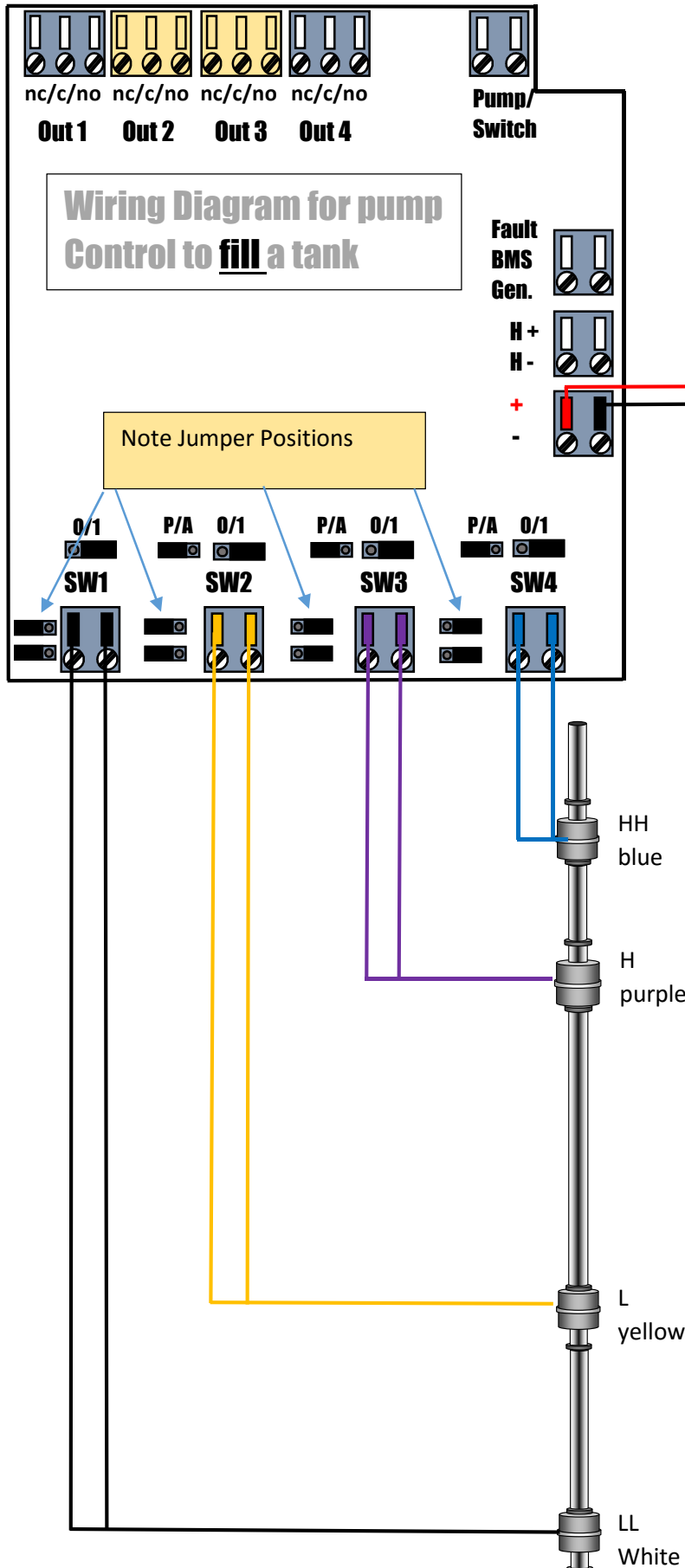

Power Supply

Units are supplied with either 24vdc direct connection, or 100/240 Vac power supply.

Power supply connection can be made by removing the mounting bracket screws temporarily



Connection Settings.

- 1/ Float switches from OLE are closed (NC), when they are in the DOWN position.
- 2/ The T4000 inputs can be switched from NC to NO as required using the 2 jumpers on each circuit.
- 3/ The 0/1 jumper can be removed to disable the Alarm circuit. (No LED)
- 4/ The P and A jumper are for when the system is being used as a Pump controller or as an Alarm.
- 5/ H+ H- is for an Audible Alarm that will activate when Flashing RED condition is present. (This is the supply voltage so 24vdc)

• Operation:

- 1/ When lights are GREEN = No Alarm
- 2/ When Lights Flash RED = Alarm / problem.
(ORANGE = PUMP ON)
- 3/ When the Acko button is pressed the Lights changed to fixed RED. This Auto resets when Alarm condition is removed.
- 4/ The BMS output (MC) changes condition (Volt Free) when any of the alarms are flashing red or solid red.
- 5/ The P and A jumper are for when the system is being used as a Pump controller or as an Alarm.
- 6/ When in Pump Control mode, Relay OUTPUTS 2 and 3 are NOT operational
- 7/ When Input 4 is in "P" (Pump Control) this also SHUTS DOWN the PUMP CIRCUIT **FAIL SAFE**

RELAYS RATED AT 240 VAC 10 AMPS