



PA



Petroleum EQUIPMENT



PA3 150



PA2 80-100



PA1 70

65
dB

EN. Electric pumps for Diesel

Self-priming volumetric vane pumps for transferring diesel fuel. The pumps are equipped with asynchronous electric self-ventilated induction engine with protection rating IP55, F type insulation class, with thermal overload protection inserted in the coil. All models are equipped with built-in by-pass valve and stainless steel filter. Cast iron body with anti-corrosion coating; sintered steel rotor and acetal resin vanes. Sturdy pumps that ensure reliability and long service life.

Features	70	80	100	150
• flow rate	70 l/min	80 l/min	100 l/min	150 l/min
• in/out	1" BSP-G	1" BSP-G	1" BSP-G	1" BSP-G
• fluids	diesel	diesel	diesel	diesel

Options

- Australian, American, English, Brazilian socket
- NPT inlet/outlet threads
- anti-siphon kit
- upon request 115V engine



ciclo di lavoro CONTINUO 70-80-100L
CONTINUOUS duty cycle 70-80-100L



ciclo di lavoro 150L
duty cycle 150L



motore - engine



Ingombri - Overall Dimensions (mm)

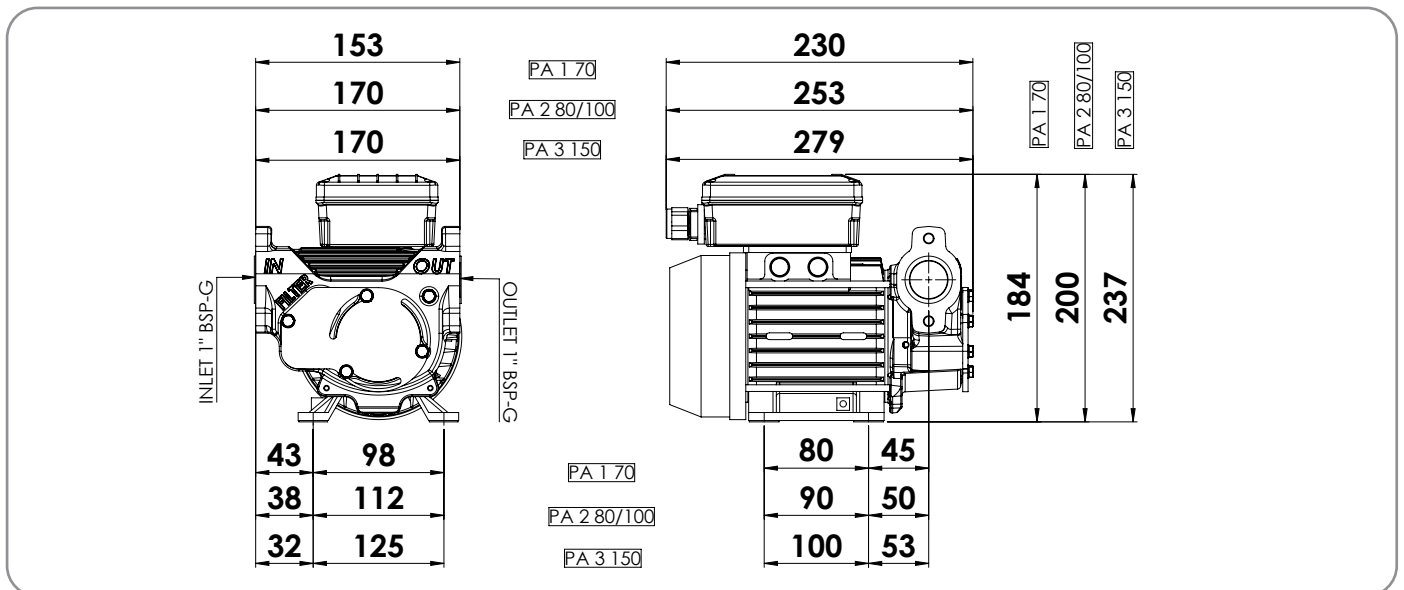

**Kit Riparazione
Repair kit**
70L ref. KIT70X
 ref. KITBY60-80-100R
80-100L ref. KIT80-100
 ref. KITBY60-80-100R
150L ref. KIT80-100
 ref. KITBY60-80-100R



**KIT ANTISIFONE
ANTISIPHON KIT**
 ref. KITANTISIF

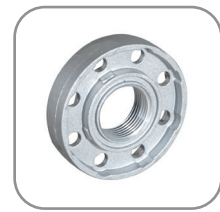

**FLANGIA
FLANGE**
 ref. TF064



Ref.	Model	l/min	V	A		LxWxH(mm)	Kg	N° boxes europallet	N° boxes europallet
PA7A00	PA1 70	70	230	2.4	2m	290X190X210	8,5	80	80
PA7A50	PA1 70	70	115 60Hz	7	2m	290X190X210	8,5	80	80
PA7A80	PA1 70	70	380	0,8	-	290X190X210	8,5	80	80
PA8000	PA2 80	80	23	3,5	2m	290X190X250	13,5	64	64
PA1007	PA2 100	100	230	4,1	2m	290X190X250	13,5	64	64
PA1500	PA3 150	150	230	14,5	2m	390X190X250	16,5	48	48