

110%
REAL CUBE
ceapet.com.au

Size	Total Fill Level (L)	Safe Fill Level (L) 95%	Length (mm)	Width (mm)	Height (mm)
CUBE3300	3300L	3000L	1589	2166	1221

07					
06					
05					
04					
03					
02					
01					
REV:	DATE:	REVISION:	DRAWN:	CHECKED:	APPROVED:

Note:
> Designed and approved to AS1940 / AS1692 / AS1657
> All welding to AS1554.1



Material:
Weight: 1111.18KG

DRAWN: DATE: 2017/6/12
CHECKED: DATE:
CLIENT: DATE:
APPROVED: DATE:

TITLE: CEA 3300L Self Bunded Cube
DRAWING NO. :
PURCHASE ORDER NO. :

REV: 01
SHEET: 1 of 3
Scale: No scale

A3



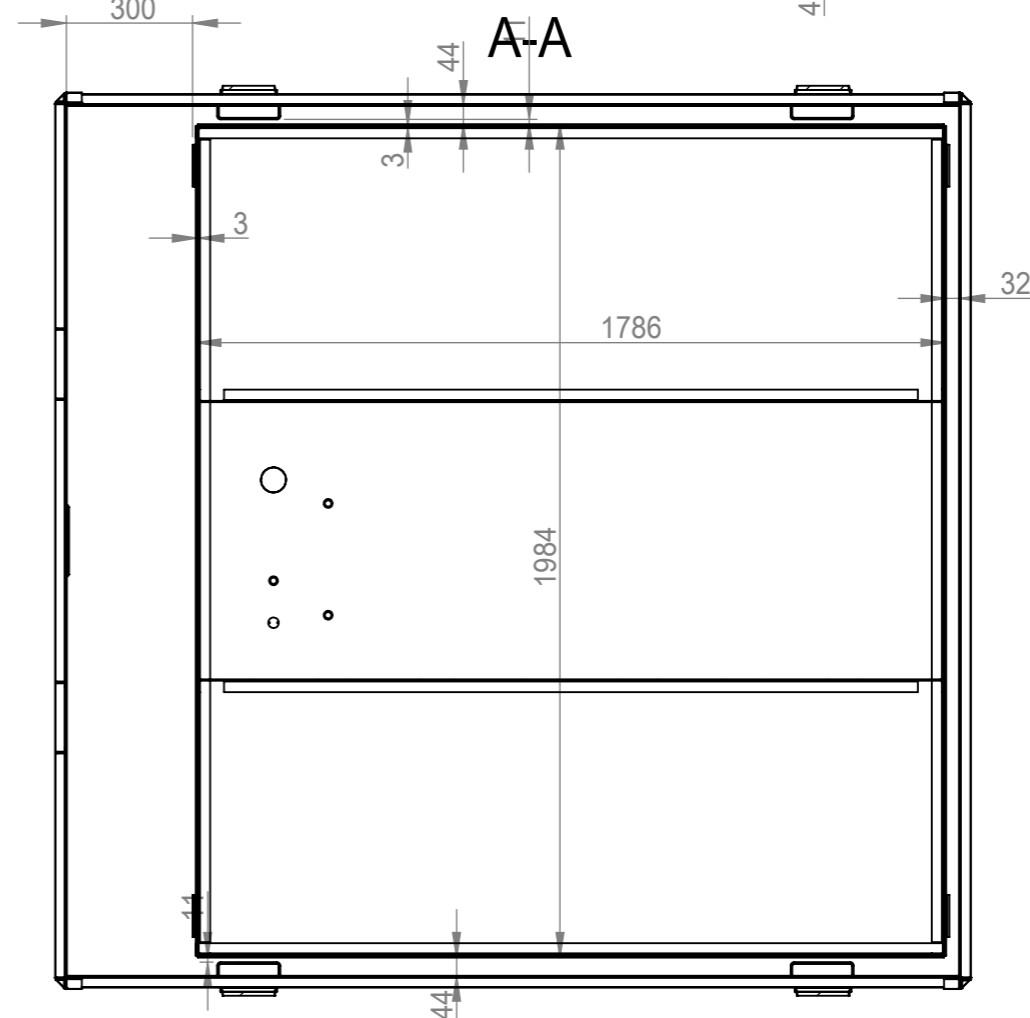
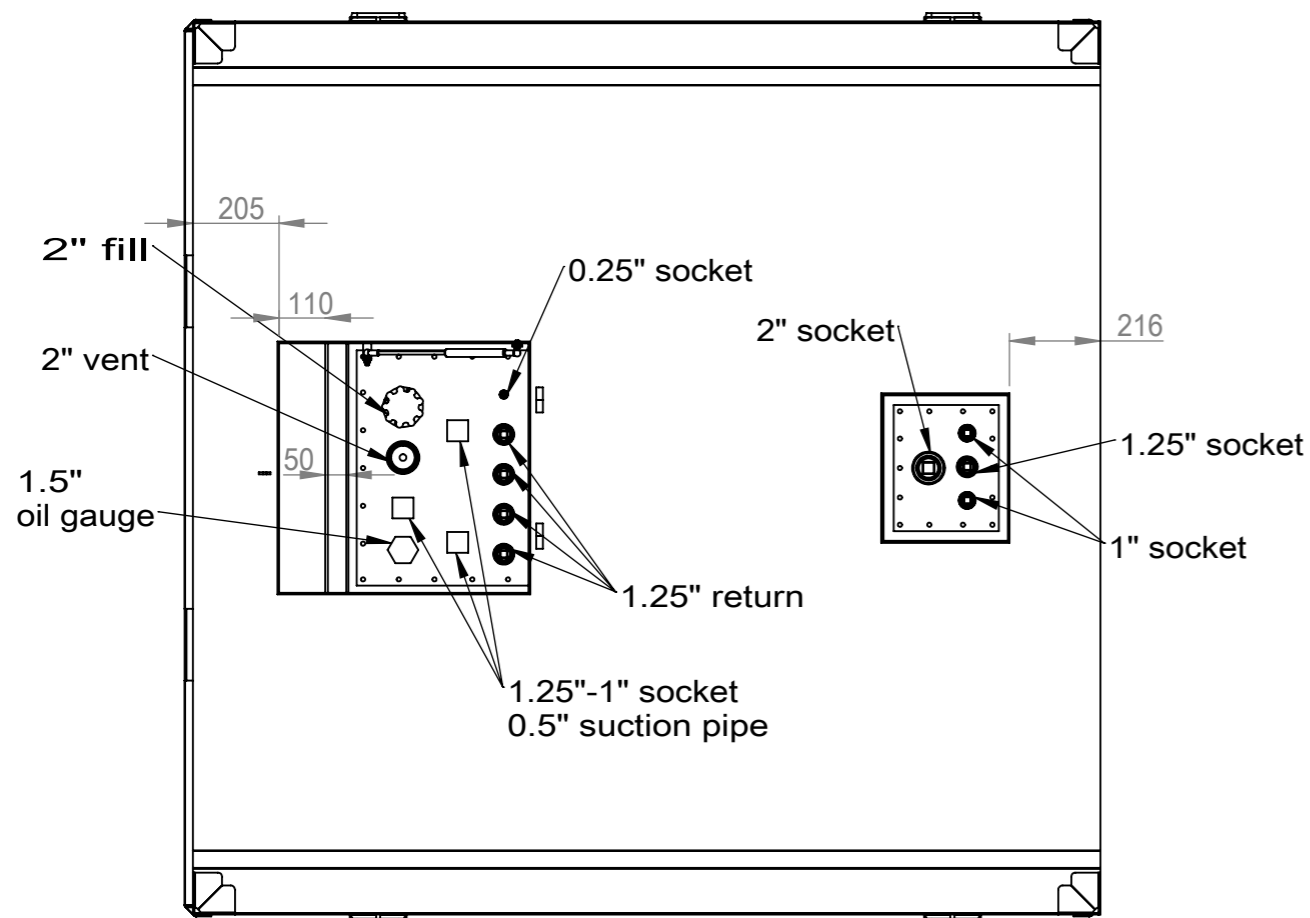
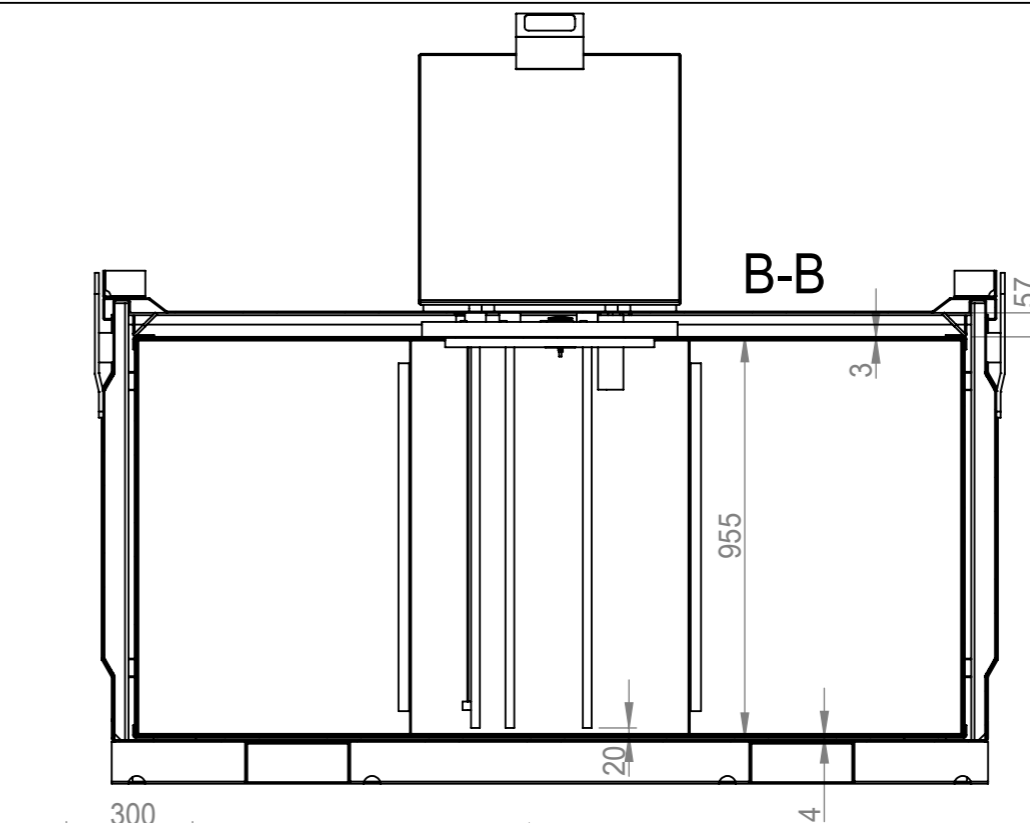
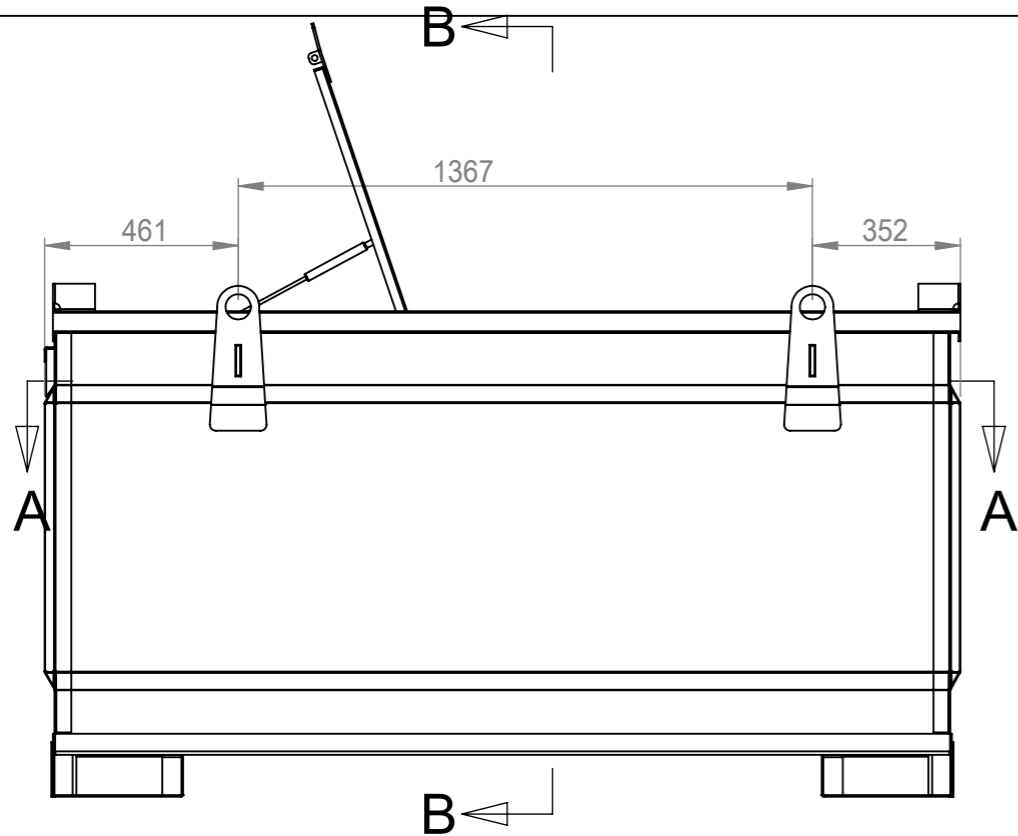

07					
06					
05					
04					
03					
02					
01					
REV:	DATE:	REVISION:	DRAWN:	CHECKED:	APPROVED:

Note:
 1.All thread is BSP ;



Material:
 Weight: 1111.18KG

DRAWN:
 CHECKED:
 CLIENT:
 APPROVED:

SAVING DATE:
 DATE:
 DATE:
 DATE:

TITLE:
 CEA 3300L Self Bunded Cube
 DRAWING NO. :
 PURCHASE ORDER NO. :

REV:
 SHEET:
 2 of 3
 Scale:
 No scale

A3

