

TANK DATA	
CONTENT	DIESEL
DESIGNED TO	AS1940
BUILT TO	AS1692, CAT. 3
CORROSION ALLOW	0mm
GROSS VOLUME	112500L
HYD. TEST PRESSURE	21KPa
SAFE FILL LEVEL	106500L
N. D. T.	Refer fabrication&assembly plan
TOTAL MASS	19148. 83Kg (EMPTY)

07					
06					
05					
04					
03					
02					
01					
REV:	DATE:	REVISION:	DRAWN:	CHECKED:	APPROVED:



CEA Petroleum Equipment

Material: _____
 Weight: 19148. 83KG

DRAWN:	SAVING DATE:	TITLE:		
	2020/4/10	48' HC	CON-110 Self Bunded Tank	
CHECKED:	DATE:	DRAWING NO. :	REV:	A3
CLIENT:	DATE:		SHEET:	
			1 of 13	
APPROVED:	DATE:	PURCHASE ORDER NO. :	Scale:	⊕ - ▢
			No scale	

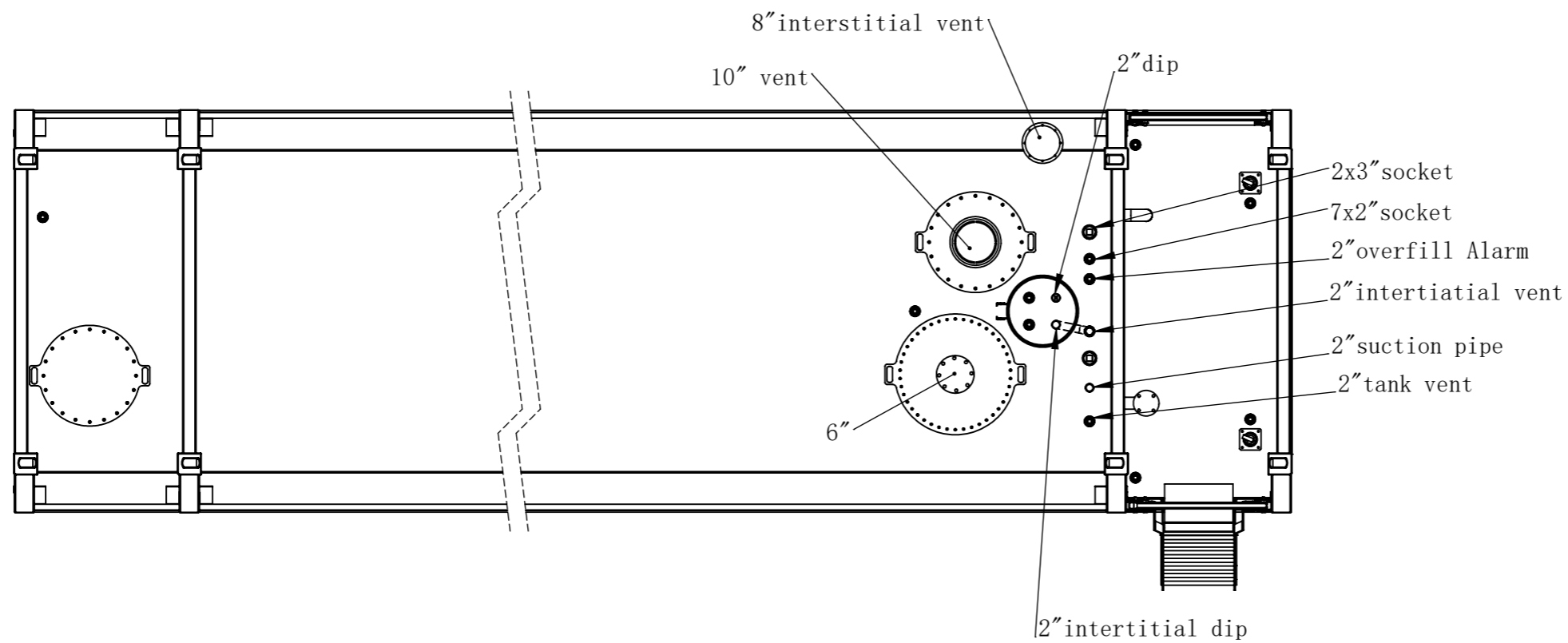
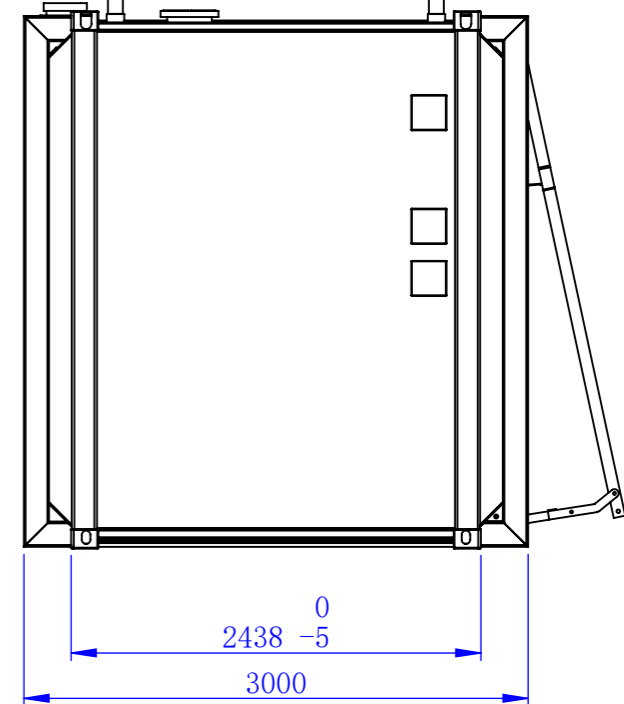
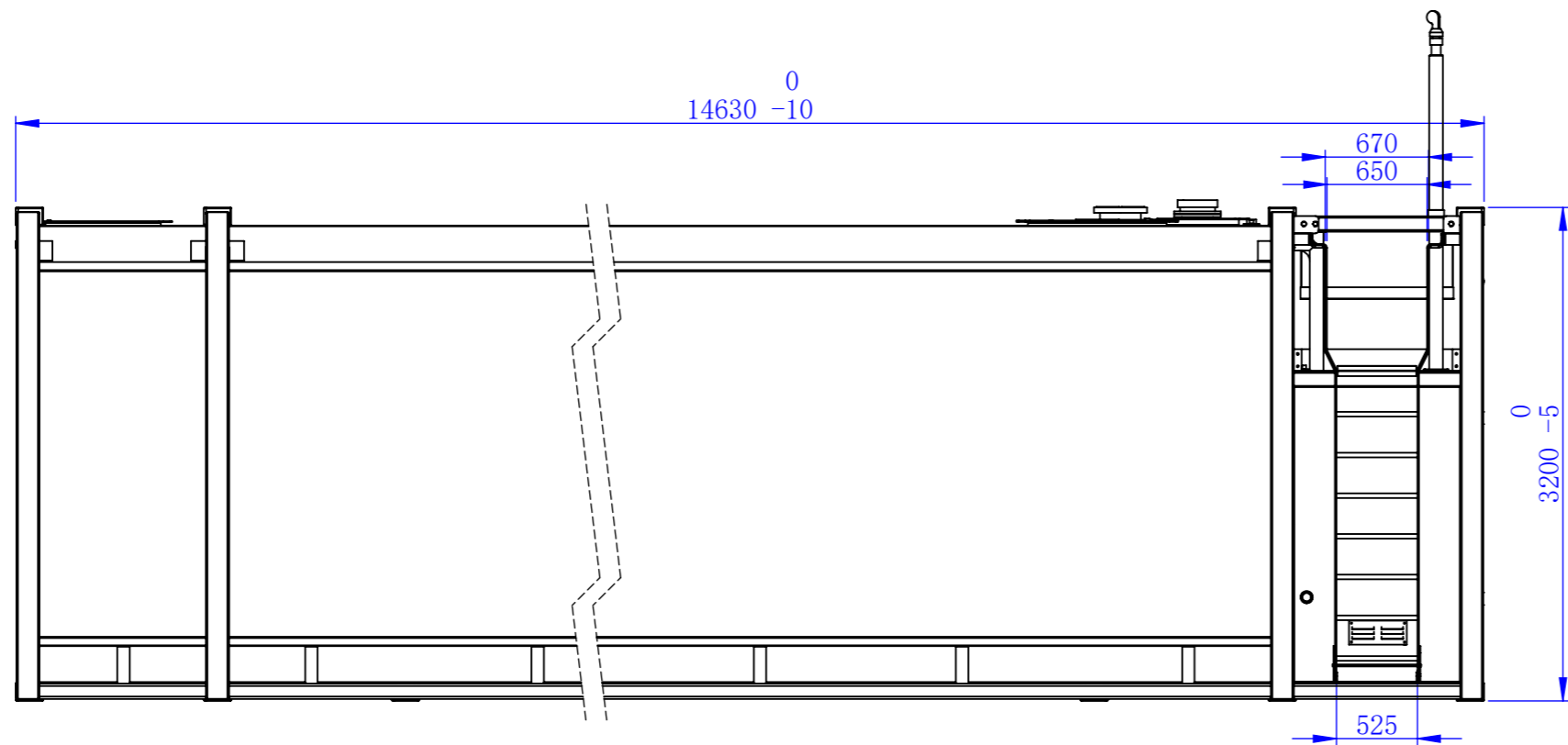

						Project :	
						CON-110 Self Bunded Tank	
						Part Name:	
						48' HC	
						Part NO. :	
NO.	Changes	File	SIGN	DATE	Material		
Design		2020/4/10	Number		Weight	19148.83KG	
CHK' D			Scale				
CHK' D							
APPV' D					⊕-▷	Revision	01
						SHEET	2
						TOTAL SHEET	13

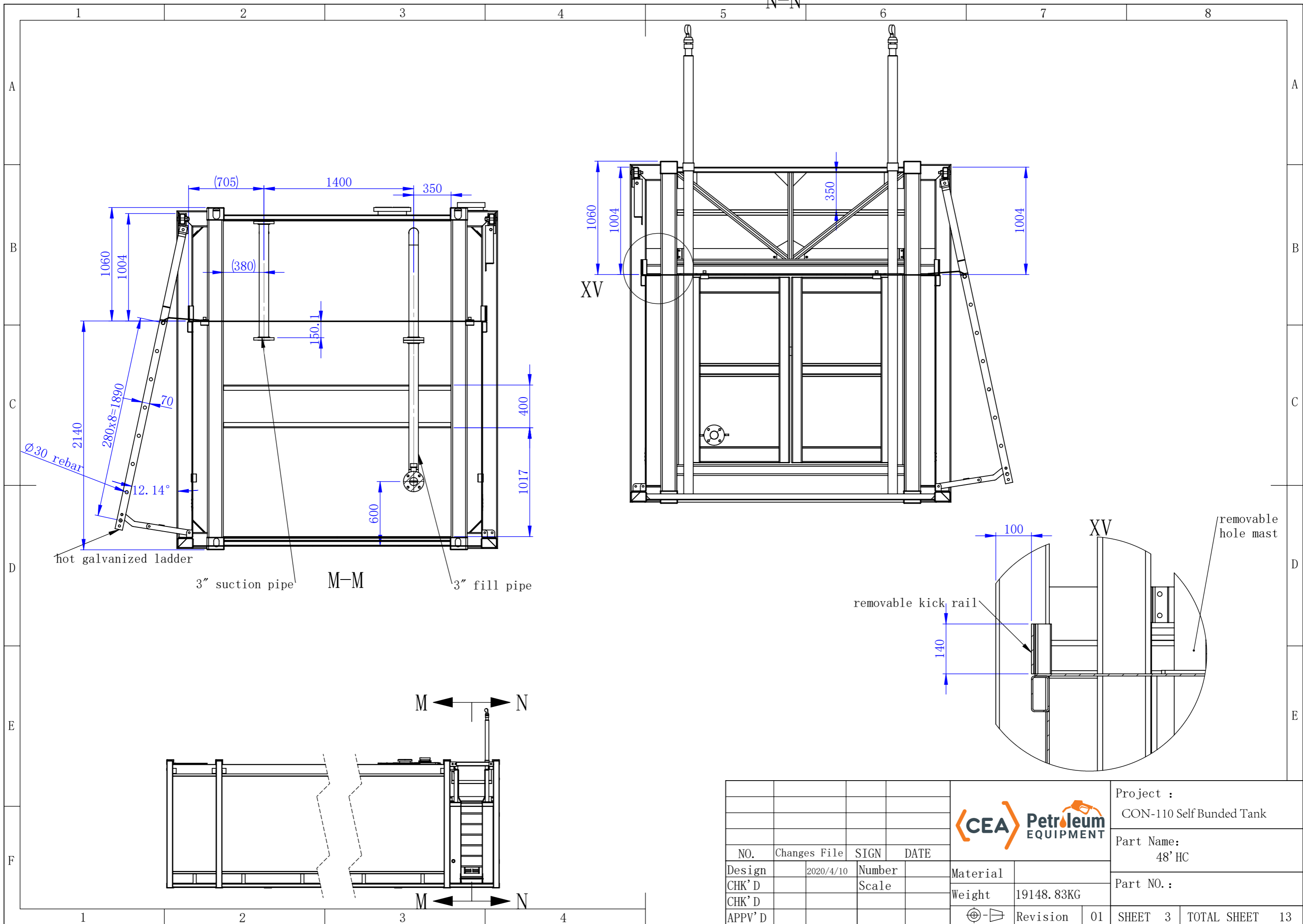

(705) 1400 350
 1060 1004 (380) 150.1
 2140 280x8=1890 70 12.14°
 Ø30 rebar
 hot galvanized ladder
 3" suction pipe
 M-M
 3" fill pipe
 600 400 1017

N-N
 1060 1004 350 1004
 XV

XV
 100
 removable kick rail
 140
 removable hole mast

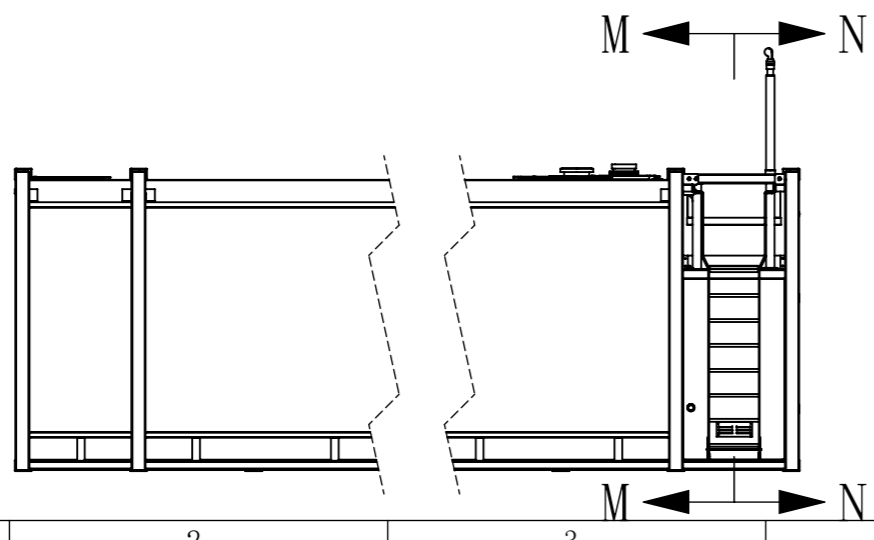

						Project :	
						CON-110 Self Bunded Tank	
				Part Name: 48' HC		Part NO. :	
NO.	Changes	File	SIGN	DATE	Material		
Design		2020/4/10			Weight	19148.83KG	
CHK' D					Revision	01	
CHK' D					SHEET 3		TOTAL SHEET 13
APPV' D							

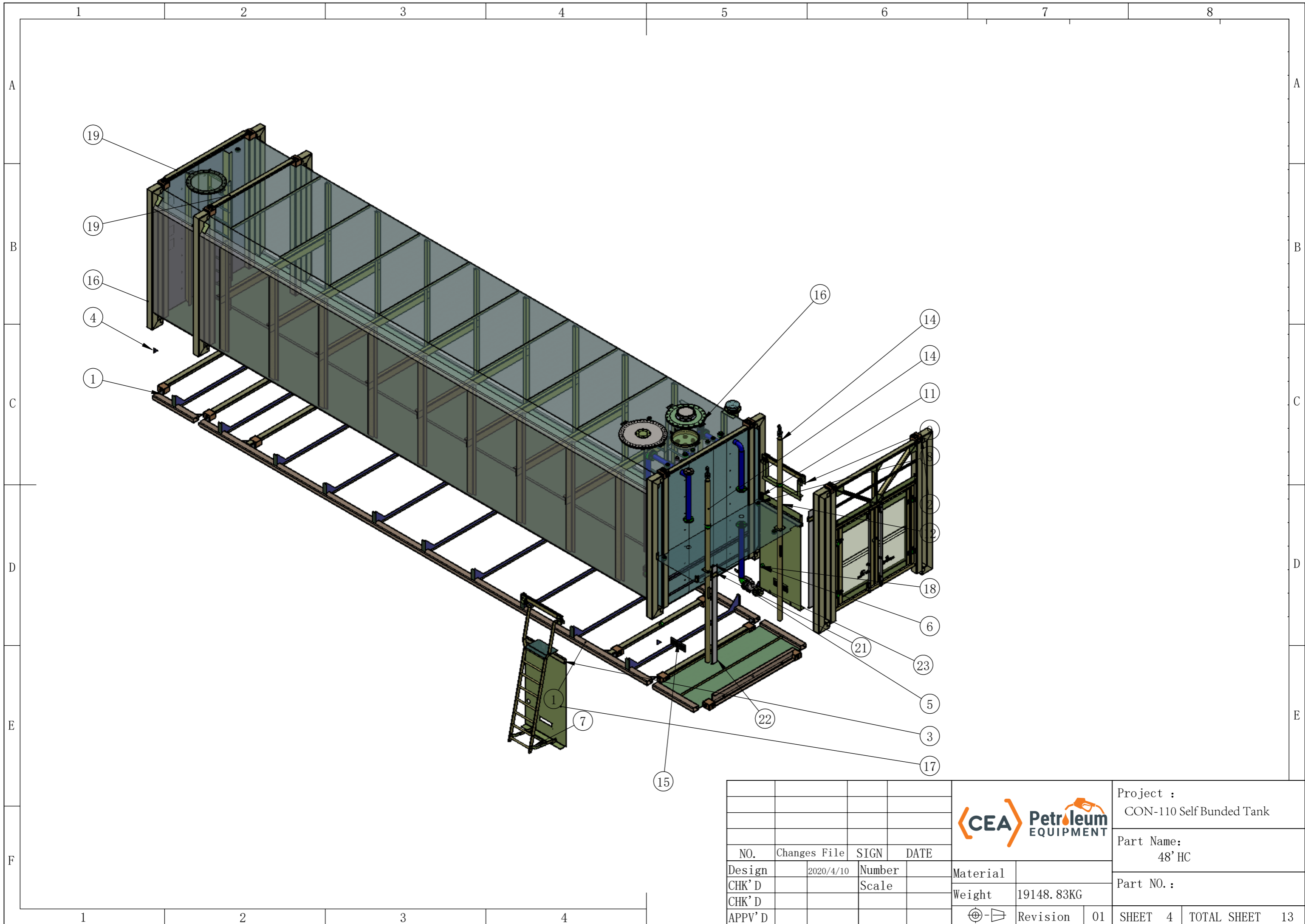

NO.	Changes	File	SIGN	DATE
Design		2020/4/10	Number	
CHK' D			Scale	
CHK' D				
APPV' D				



Project :		CON-110 Self Bunded Tank	
Part Name:		48' HC	
Part NO. :			
Material		Weight	19148.83KG
Revision	01	SHEET	4
		TOTAL SHEET	13

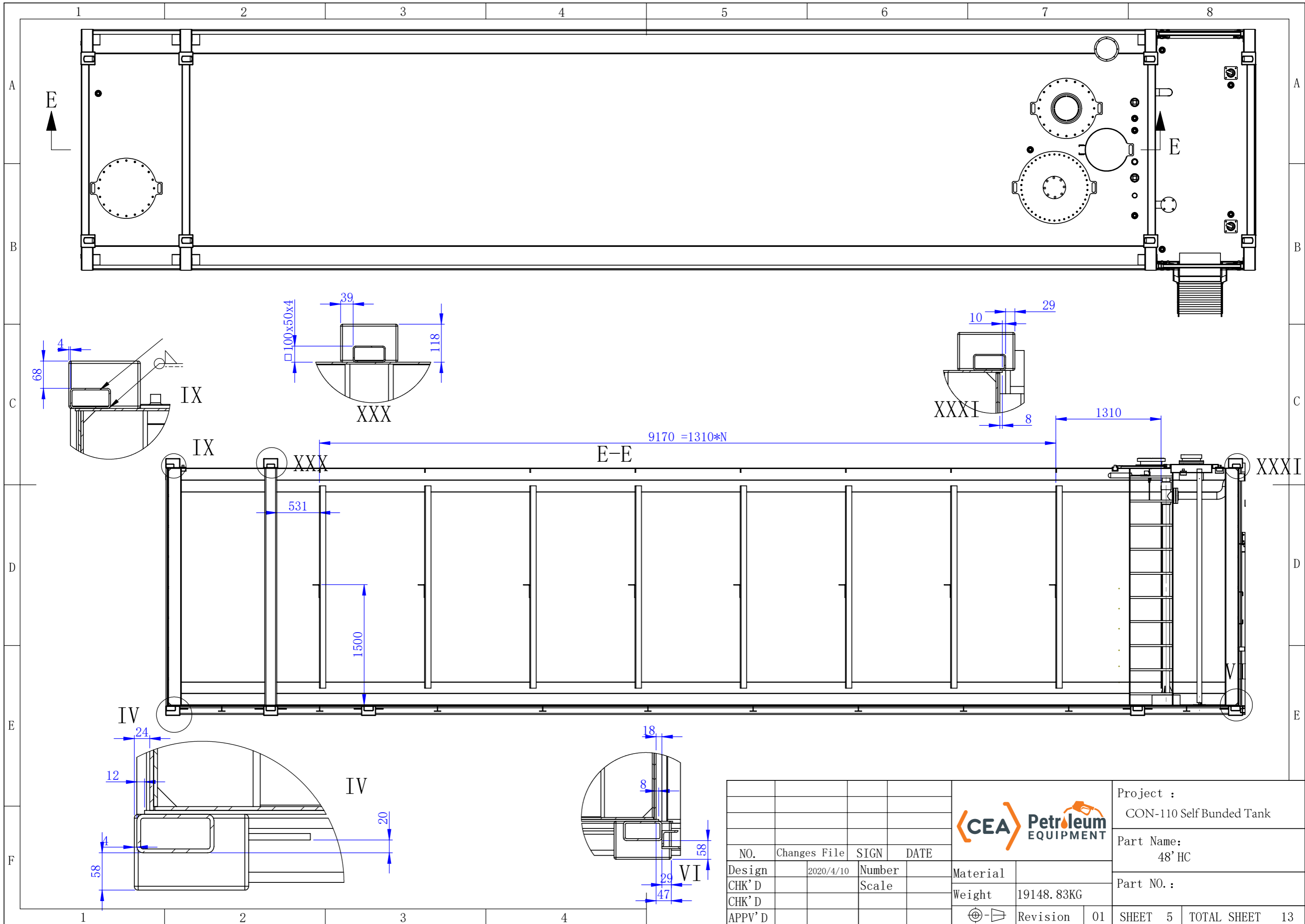

						Project :	
						CON-110 Self Bunded Tank	
						Part Name:	
						48' HC	
						Part NO. :	
NO.	Changes	File	SIGN	DATE	Material		
Design		2020/4/10			Weight	19148.83KG	
CHK' D					Revision	01	
CHK' D					SHEET	5	TOTAL SHEET
APPV' D							13