

Tank	
TANK CONTENTS	
DESIGNED TO	AS1940 / AS1692
BUILT TO	AS1657 / AS1554.1
PLATE THICKNESS, Material	4/4 mm, Q235B
Pressue Test	35KPA
External size	2966x2294x1270mm
Internal size	2858x2186x1058mm
GROSS VOLUME	6600L
SAFE FILL LEVEL	6000L
N. D. T.	Require By Client
TOTAL MASS	1823.18KG

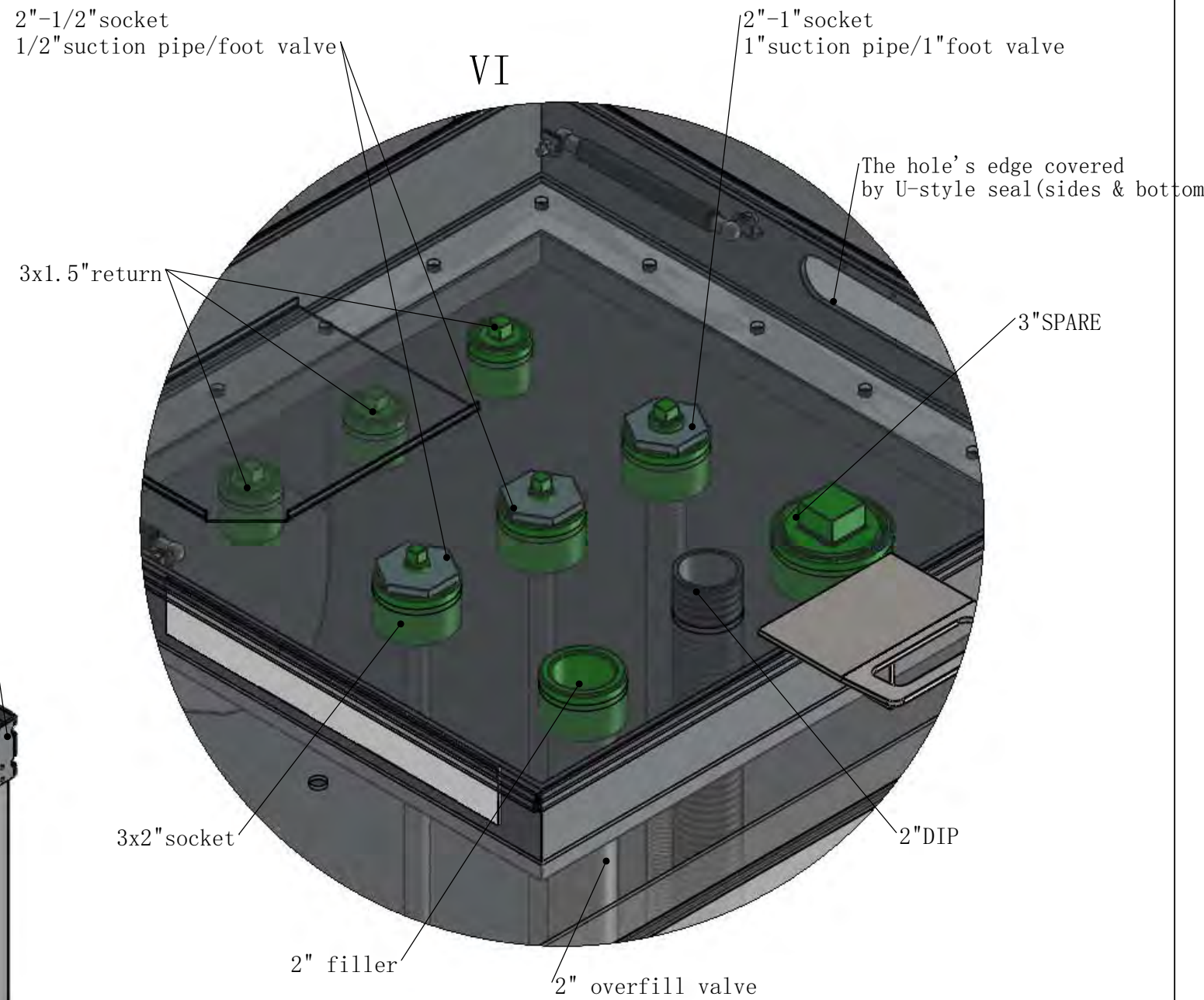

07					
06					
05					
04					
03					
02					
01					
REV:	DATE:	REVISION:	DRAWN:	CHECKED:	APPROVED:

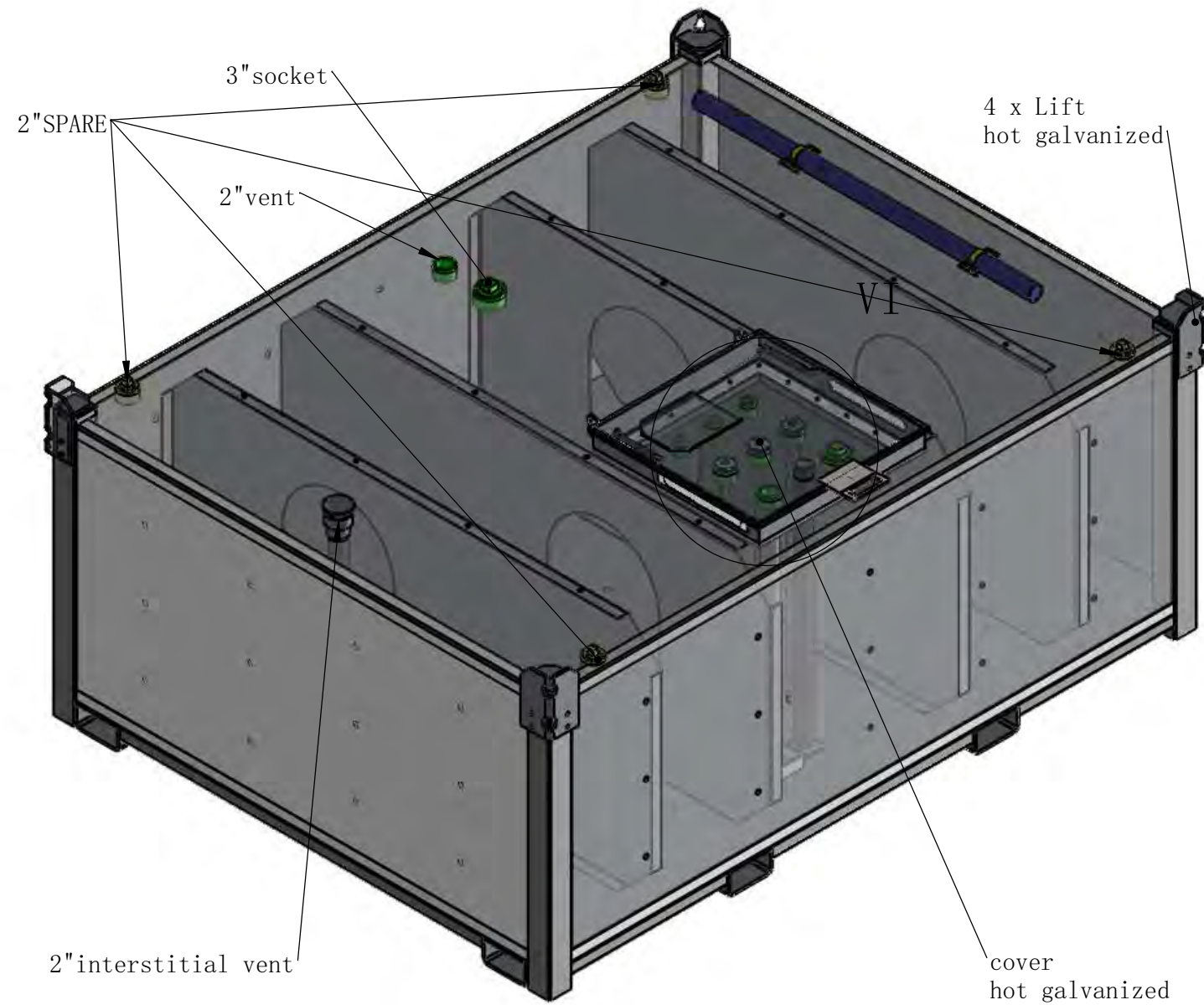

Material:	
Weight:	1823.18KG

DRAWN:	DATE:
CHECKED:	DATE:
CLIENT:	DATE:
APPROVED:	DATE:

TITLE:		CEA BOX 6600L Self Bunded Tank	
DRAWING NO. :		REV:	A3
		01	
PURCHASE ORDER NO. :		SHEET:	1 of 4
		Scale:	No scale

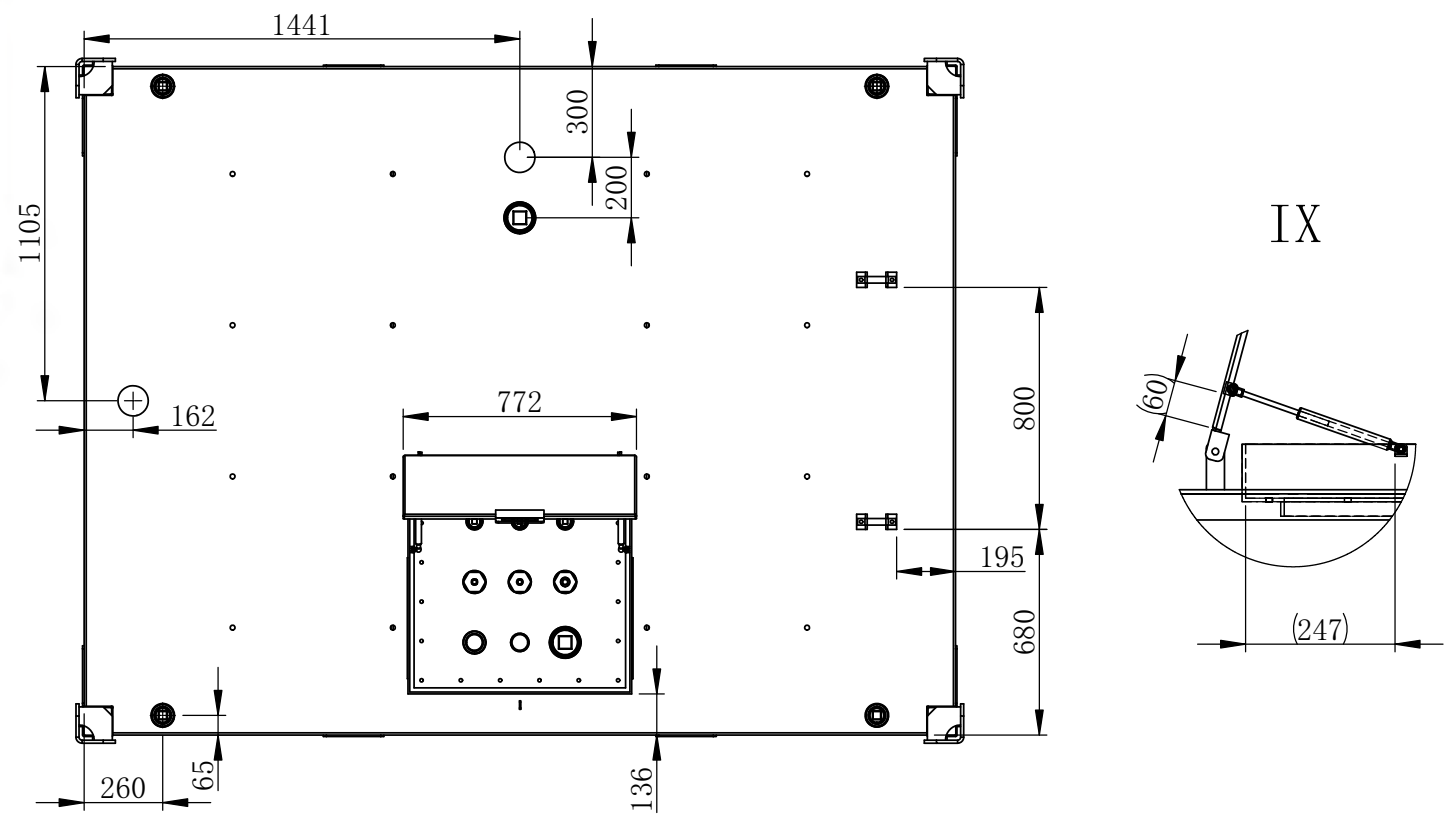
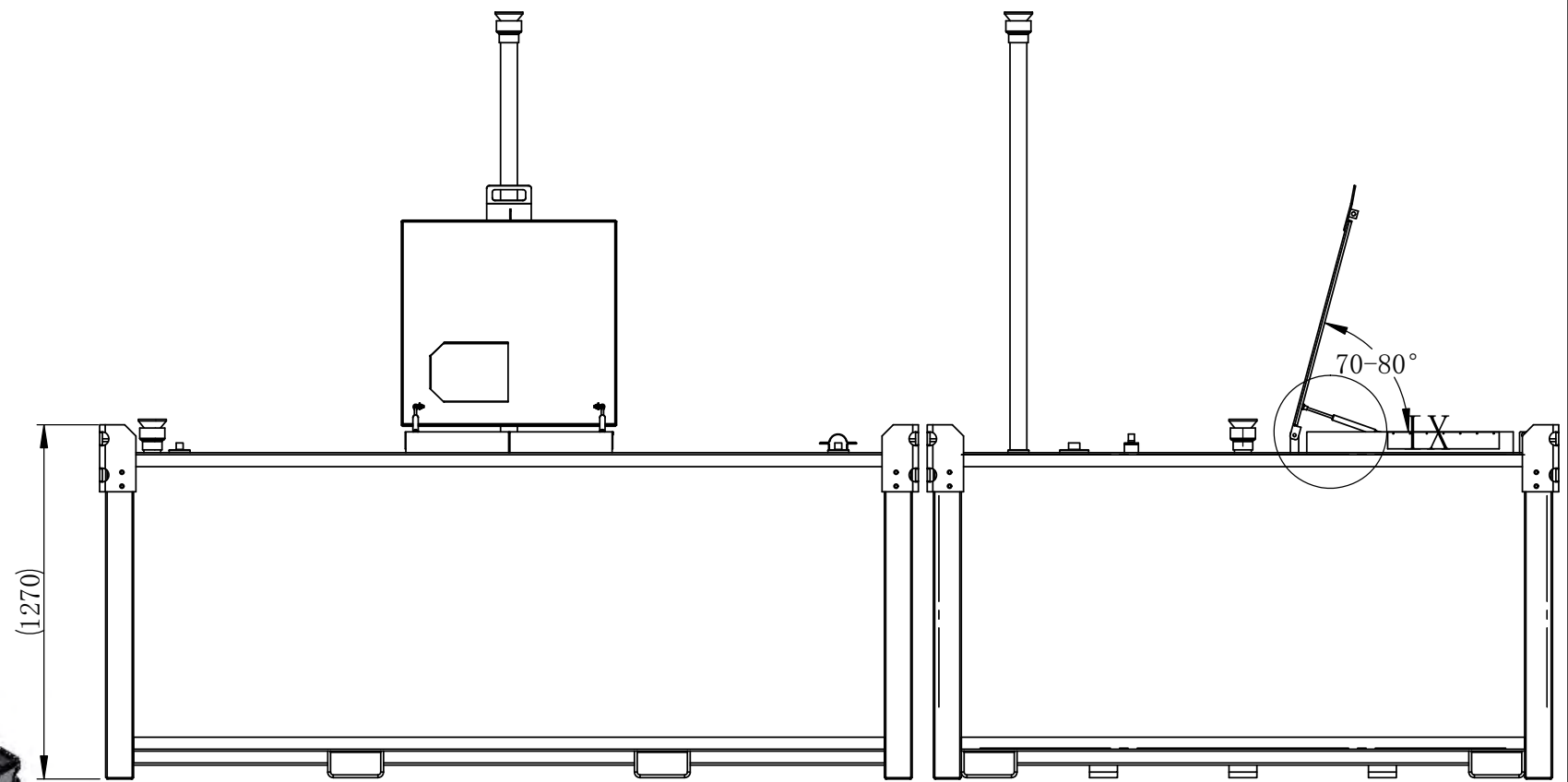
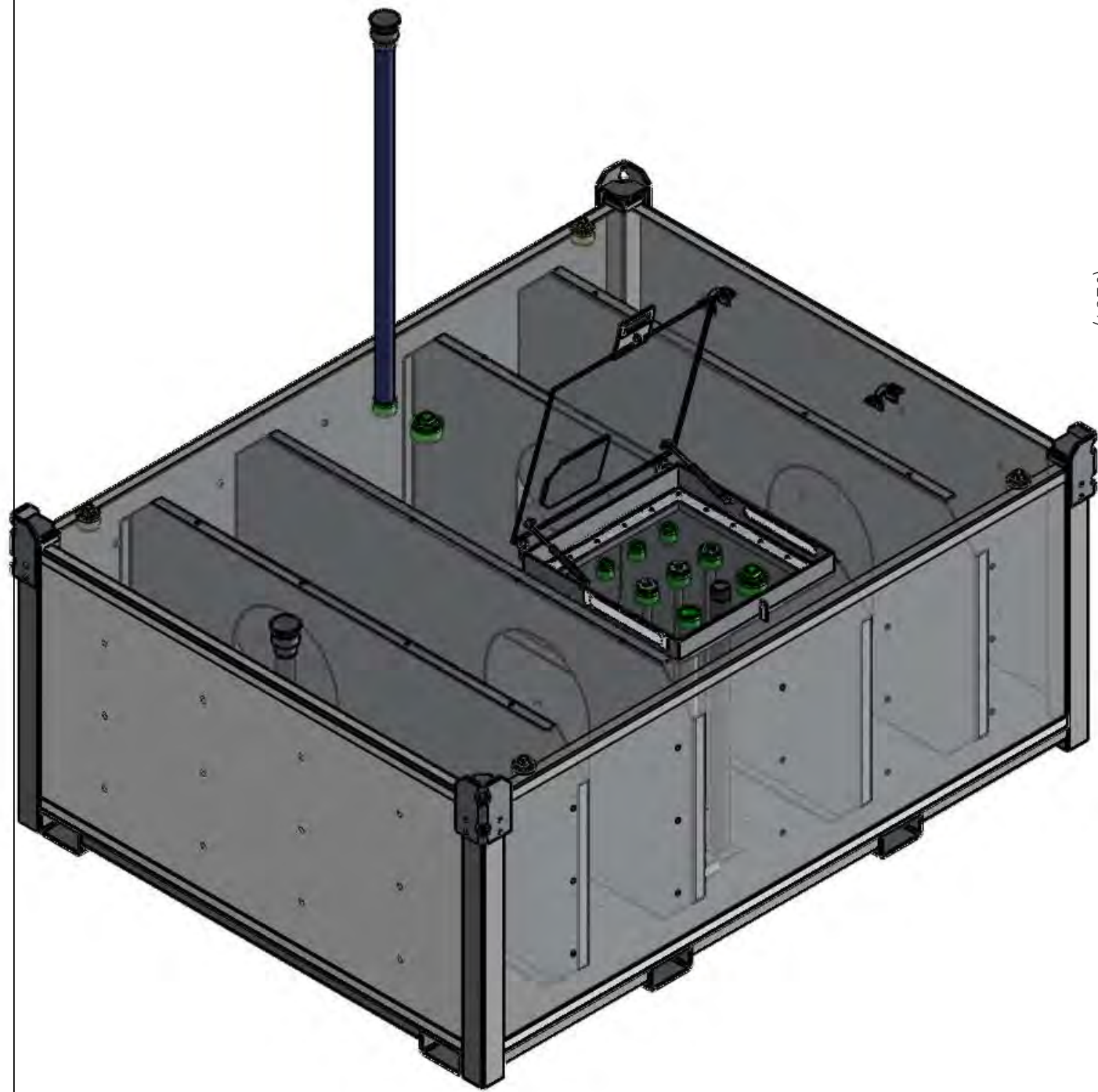

07					
06					
05					
04					
03					
02					
01					
REV:	DATE:	REVISION:	DRAWN:	CHECKED:	APPROVED:



DRAWN:		DATE:	TITLE:	
CHECKED:		DATE:	CEA BOX 6600L Self Bunded Tank	
CLIENT:		DATE:	DRAWING NO. :	REV: 01
APPROVED:		DATE:	PURCHASE ORDER NO. :	SHEET: 2 of 4
Material:				Scale: No scale
Weight:	1823.18KG			A3

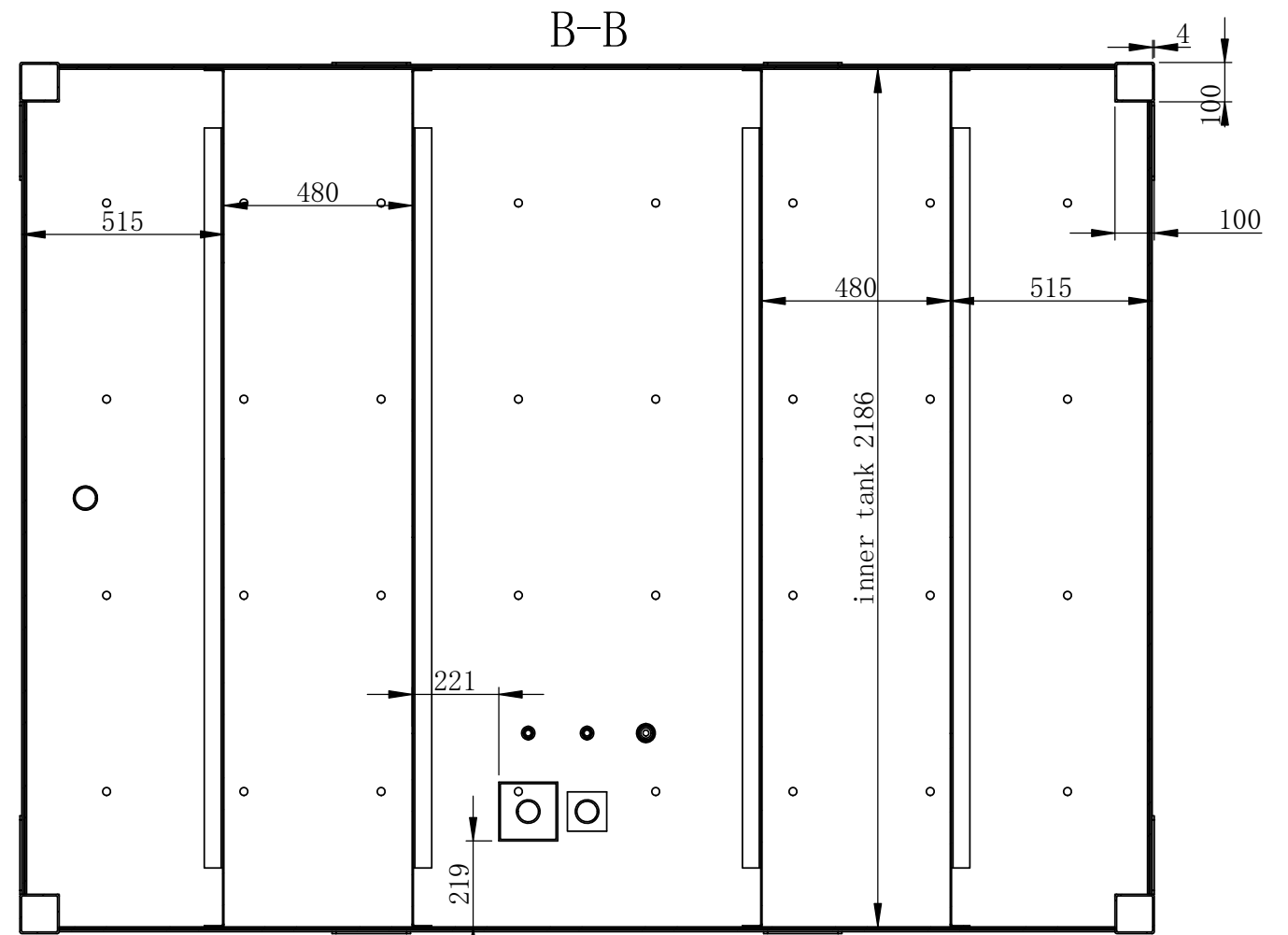
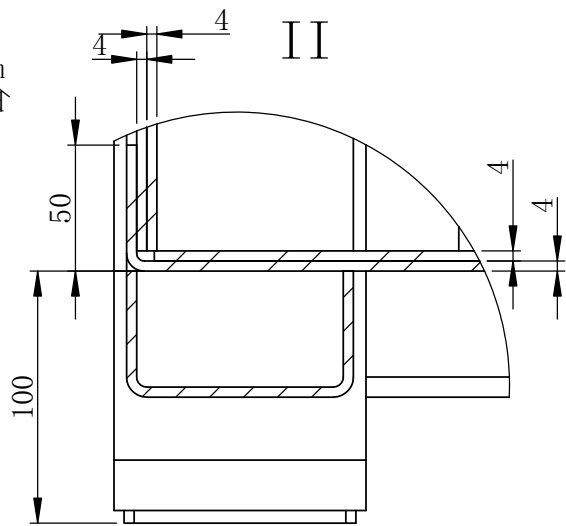
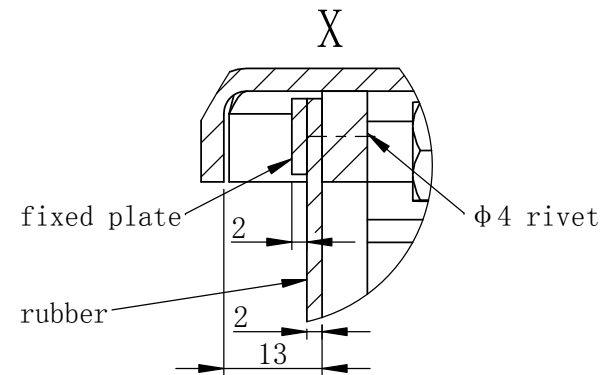
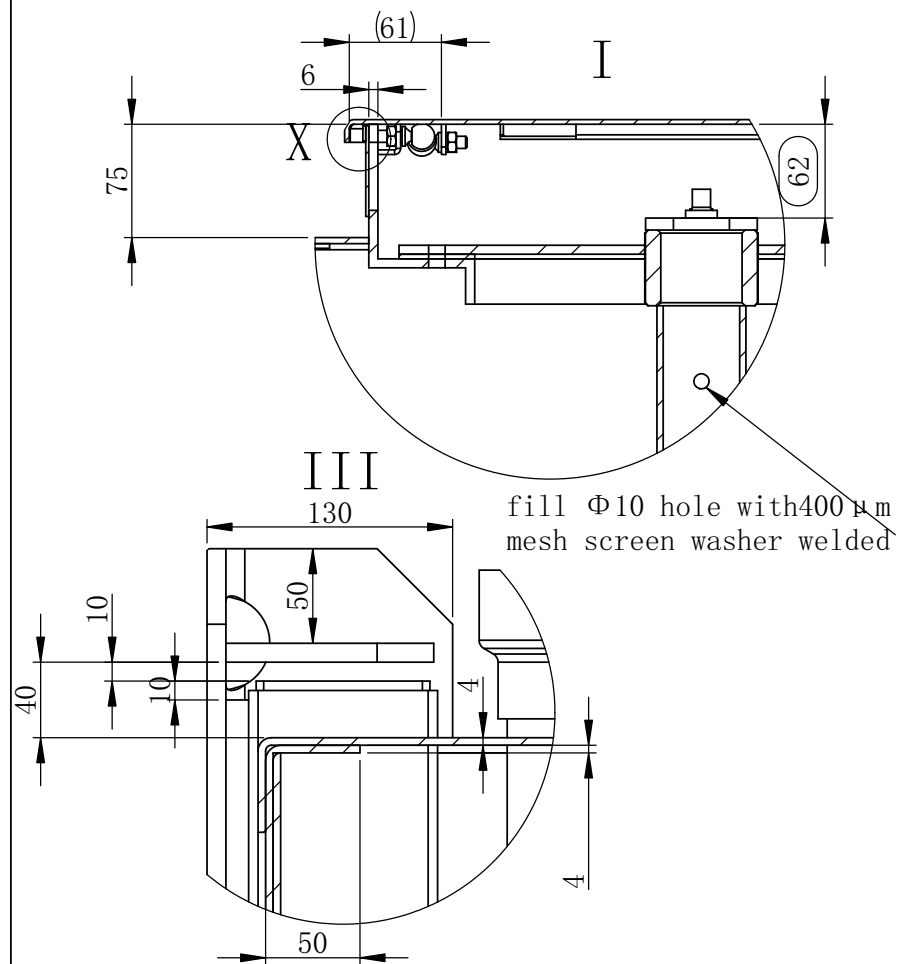
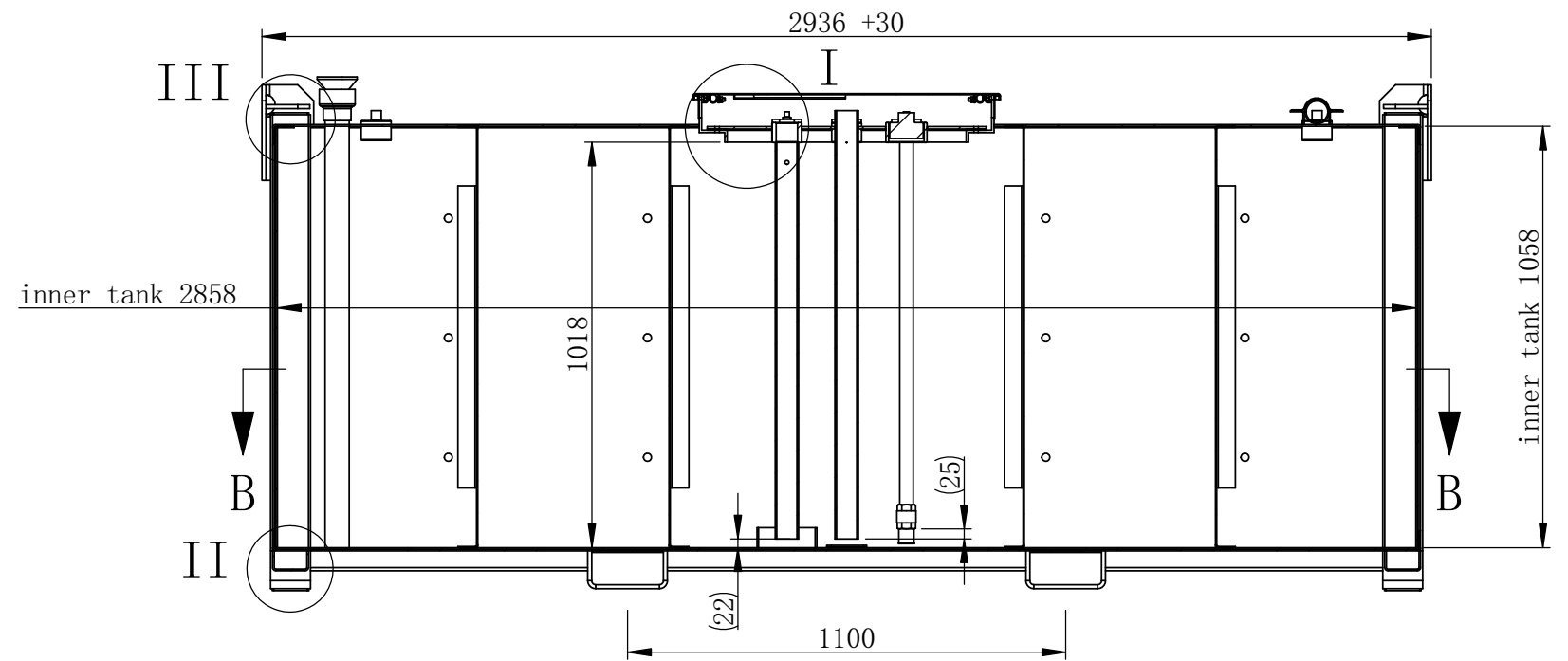
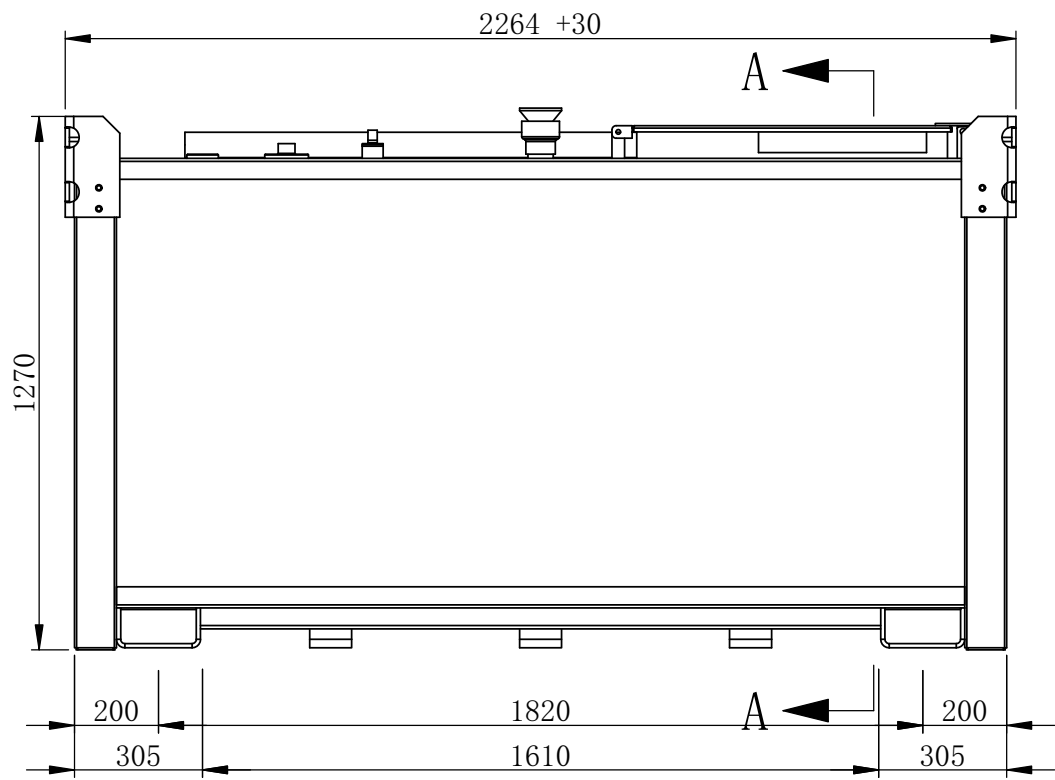

07					
06					
05					
04					
03					
02					
01					
REV:	DATE:	REVISION:	DRAWN:	CHECKED:	APPROVED:



Material:	
Weight:	1823.18KG

DRAWN:	DATE:
CHECKED:	DATE:
CLIENT:	DATE:
APPROVED:	DATE:

TITLE:		REV:	A3
CEA BOX 6600L Self Bunded Tank			
DRAWING NO. :		SHEET:	Scale: $\oplus$ - $\nabla$
		3 of 4	
PURCHASE ORDER NO. :		Scale: No scale	

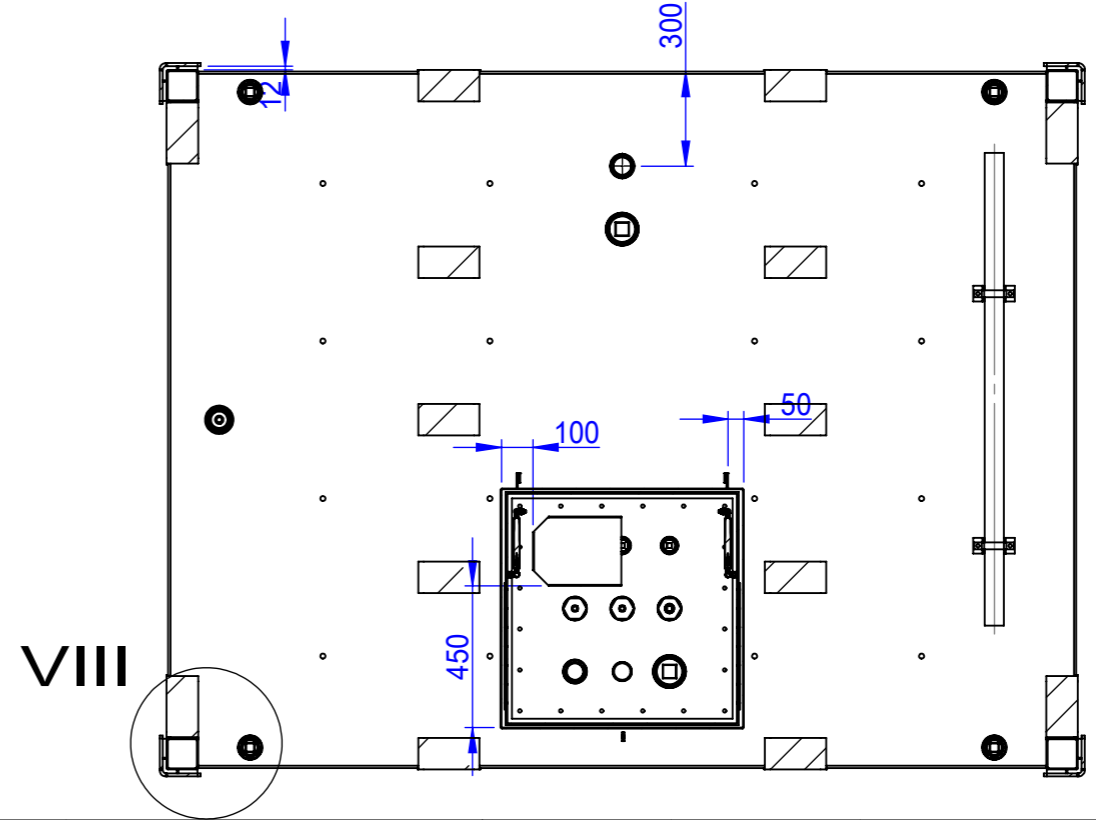
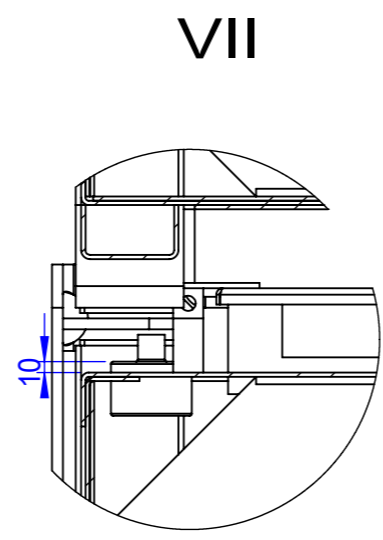
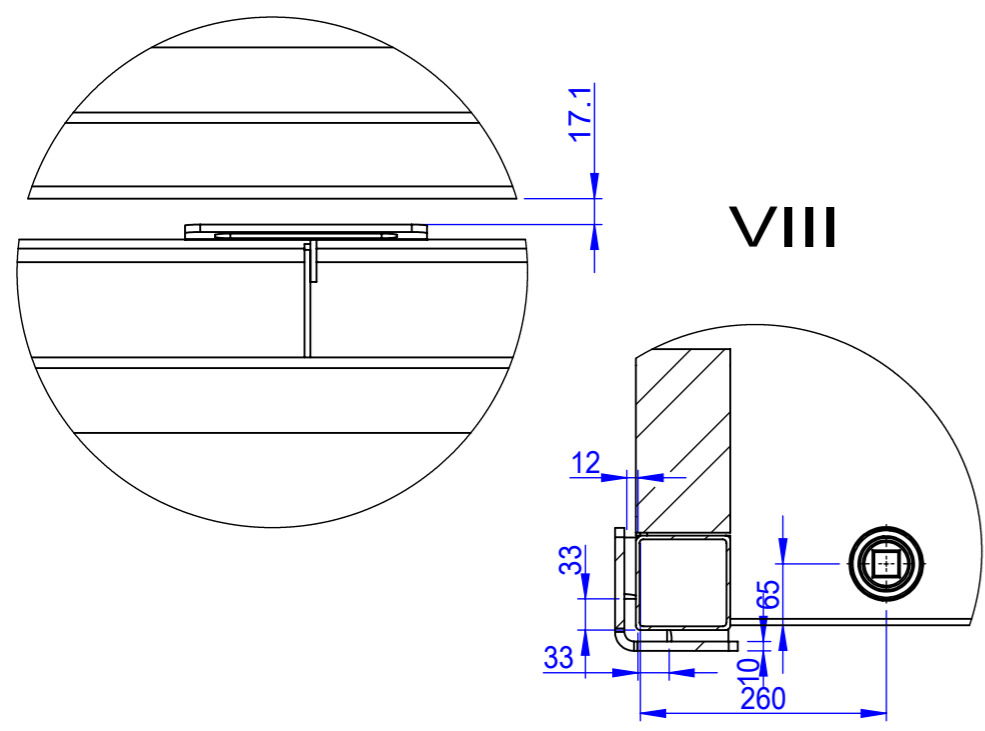
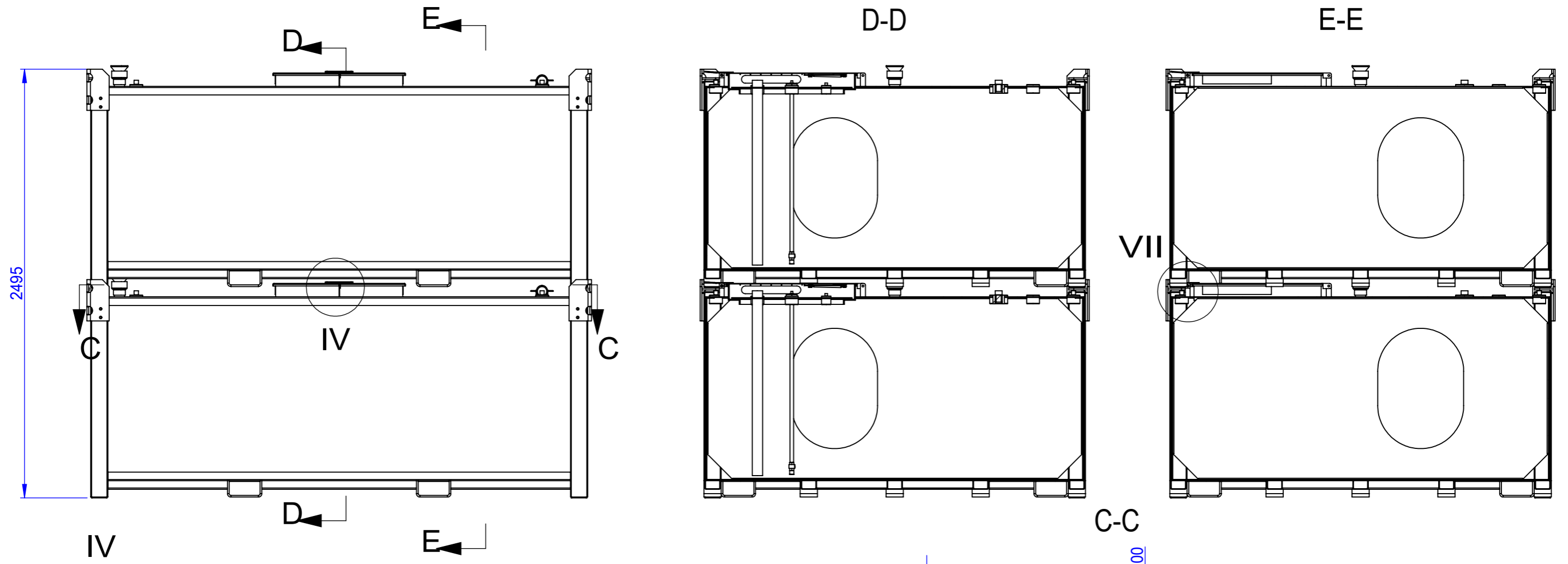

07					
06					
05					
04					
03					
02					
01					
REV:	DATE:	REVISION:	DRAWN:	CHECKED:	APPROVED:



Material:	
Weight:	3642.81KG

DRAWN:	DATE:
CHECKED:	DATE:
CLIENT:	DATE:
APPROVED:	DATE:

TITLE:		REV:	A3
CEA BOX 6600L Self Bunded Tank			
DRAWING NO. :		SHEET:	Scale:
PURCHASE ORDER NO. :		4 of 4	
		Scale:	No scale