

Tank	
TANK CONTENTS	
DESIGNED TO	AS1940 / AS1692
BUILT TO	AS1657 / AS1554.1
PLATE THICKNESS, Material	4/4 mm, Q235B
Pressue Test	35KPA
External size	724x1086x1270mm
Internal size	616x978x1008mm
GROSS VOLUME	600L
SAFE FILL LEVEL	550L
N. D. T.	Require By Client
TOTAL MASS	405.18KG

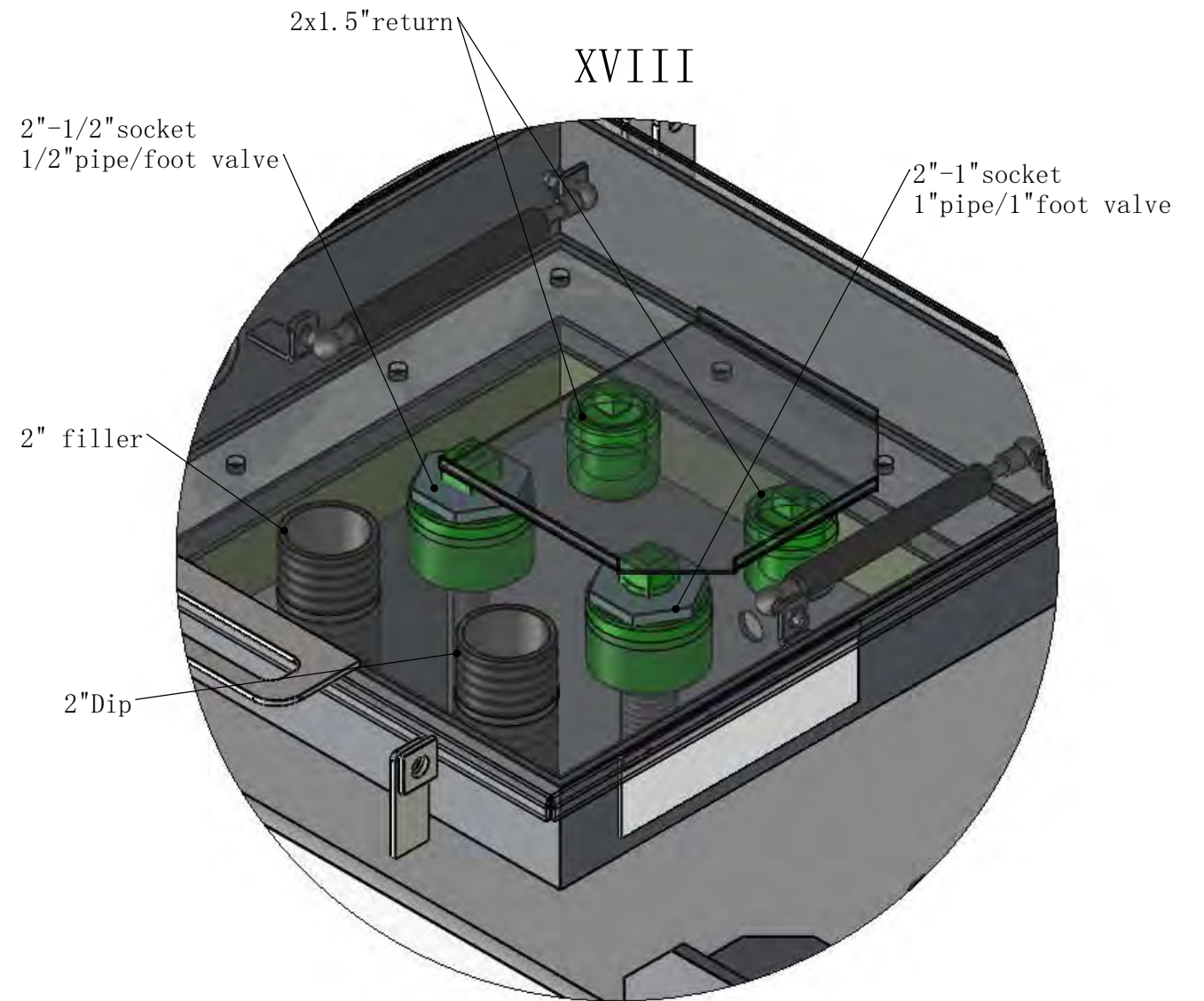

07					
06					
05					
04					
03					
02					
01					
REV:	DATE:	REVISION:	DRAWN:	CHECKED:	APPROVED:

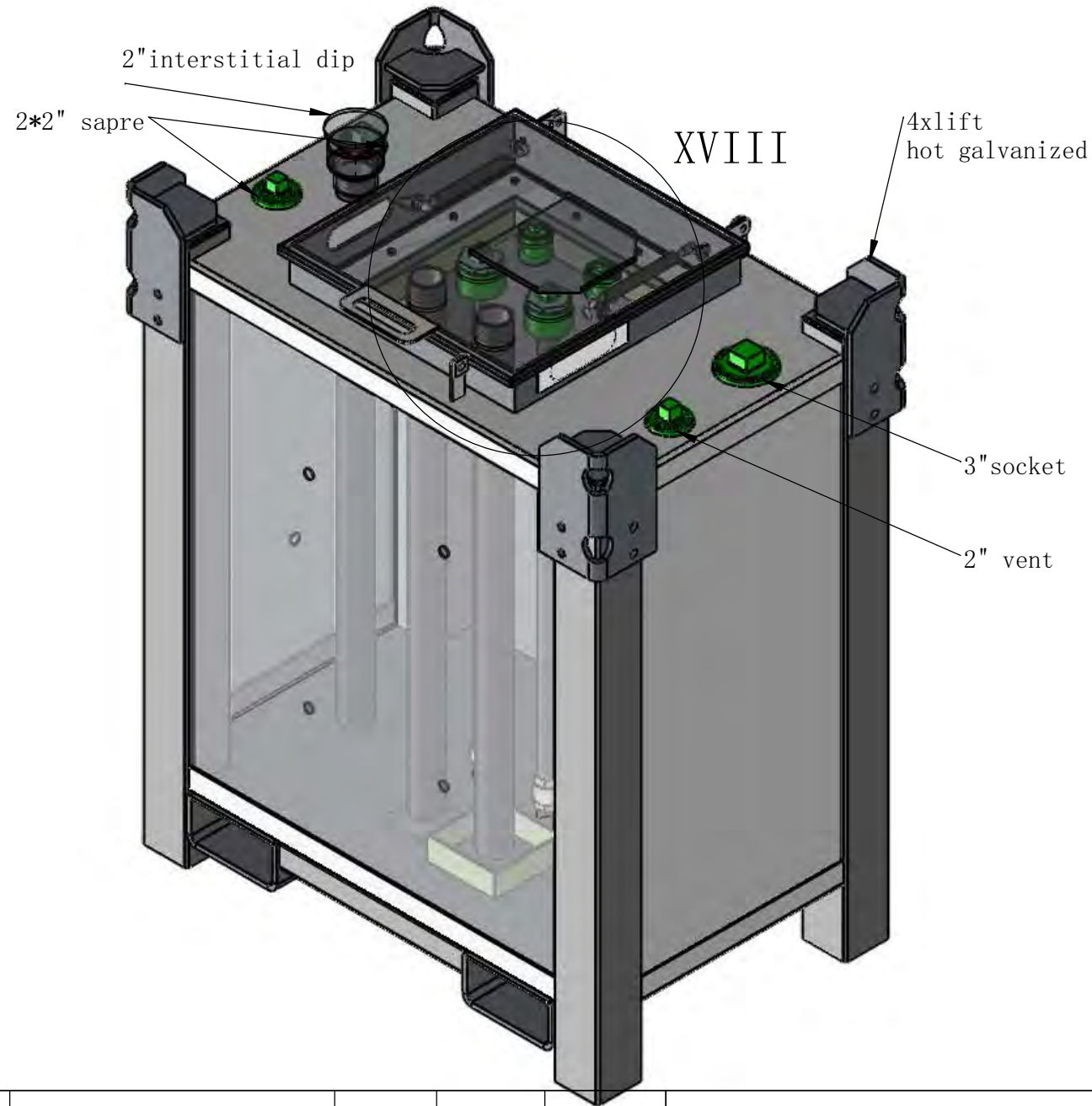

	DRAWN:	DATE:	TITLE:	
		2020-10-30	600L BOX SELF BUNDED TANK	
	CHECKED:	DATE:	DRAWING NO. :	REV:
	CLIENT:	DATE:		01
				SHEET:
				1 of 3
				Scale:
				No scale
			PURCHASE ORDER NO. :	⊕ - ▢
Material:		APPROVED:		
Weight:	405.18KG	DATE:		

A3

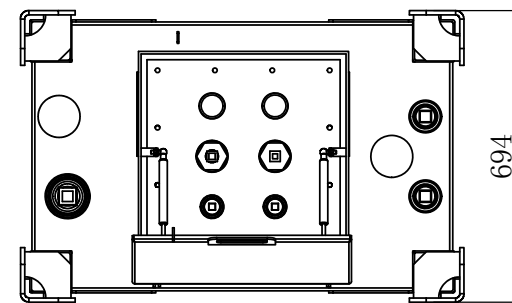
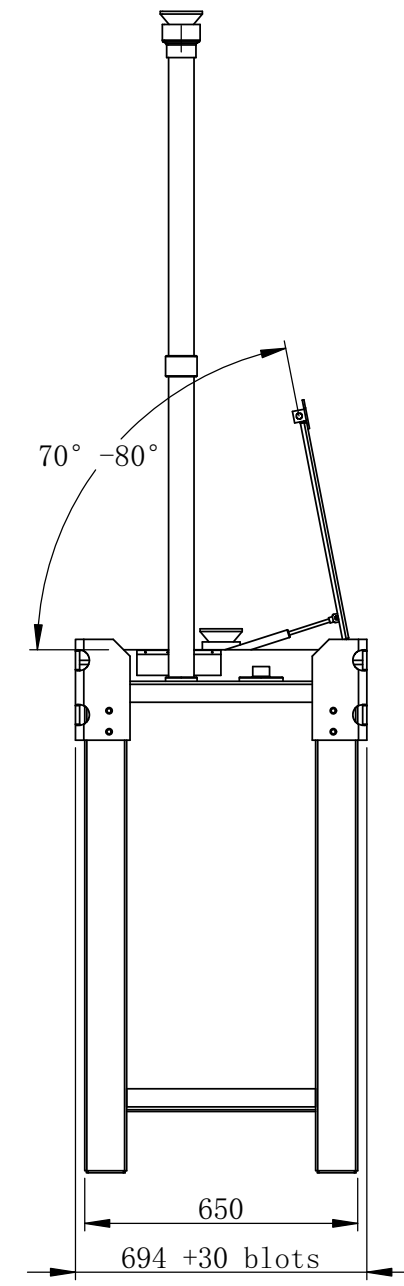
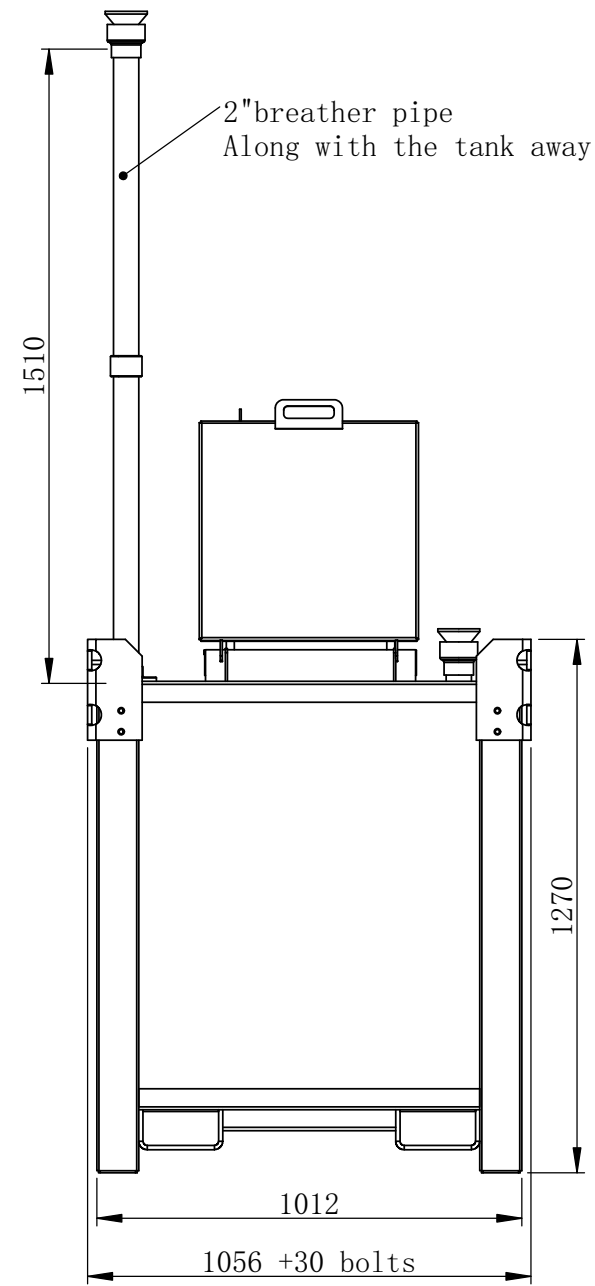
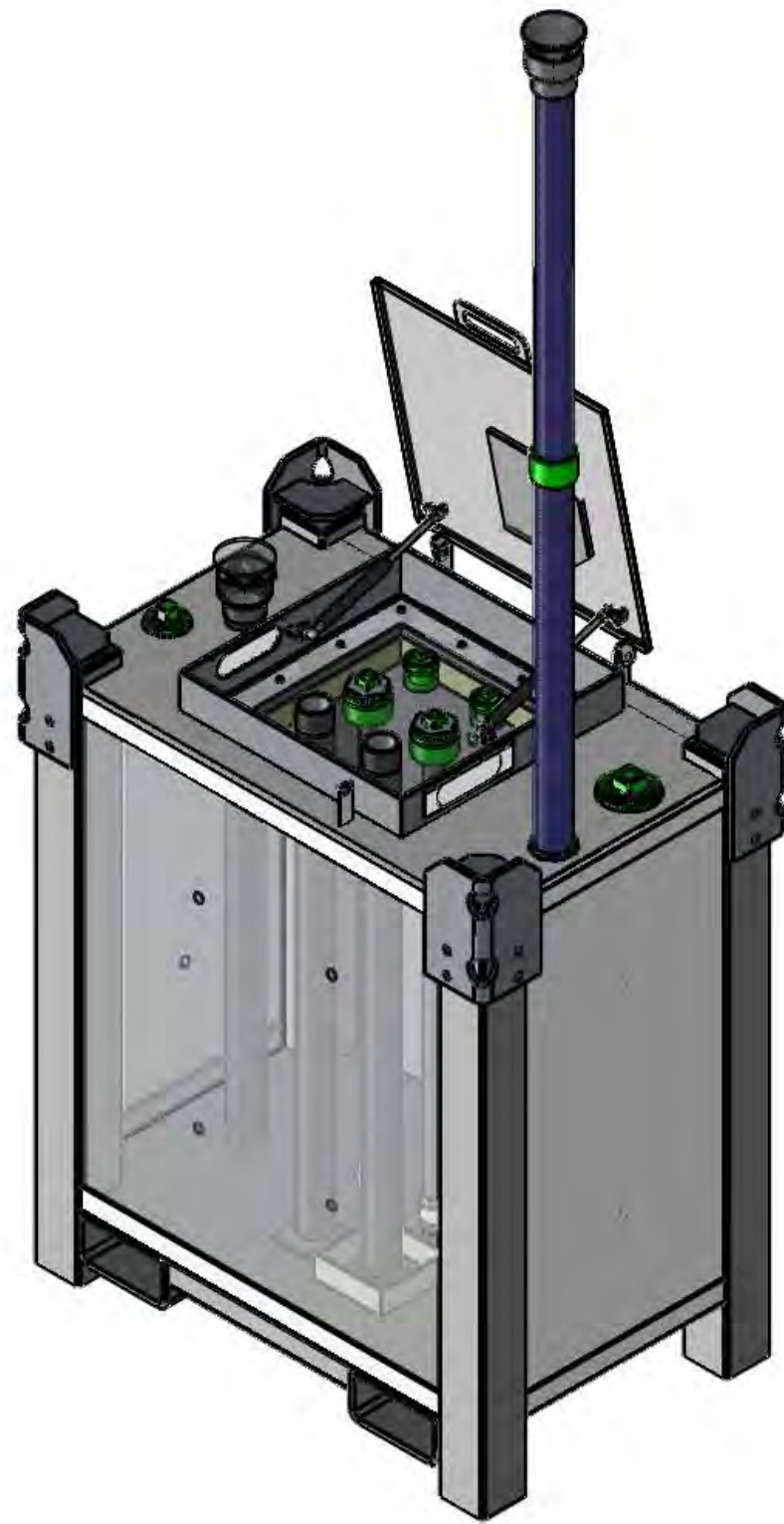

07					
06					
05					
04					
03					
02					
01					
REV:	DATE:	REVISION:	DRAWN:	CHECKED:	APPROVED:



Material:
Weight: 405.18KG

DRAWN:
DATE: 2020-10-30
CHECKED:
DATE:
CLIENT:
DATE:
APPROVED:
DATE:

TITLE:
600L BOX SELF BUNDED TANK
DRAWING NO. :
PURCHASE ORDER NO. :

REV: 01
SHEET: 2 of 3
Scale: No scale

A3



