

Tank	
TANK CONTENTS	
DESIGNED TO	AS1940 / AS1692
BUILT TO	AS1657 / AS1554.1
PLATE THICKNESS, Material	4/4 mm, Q235B
Pressue Test	35KPA
External size	2294x1086x1270mm
Internal size	2186x978x1058mm
GROSS VOLUME	2250L
SAFE FILL LEVEL	2000L
N. D. T.	Require By Client
TOTAL MASS	887.62KG

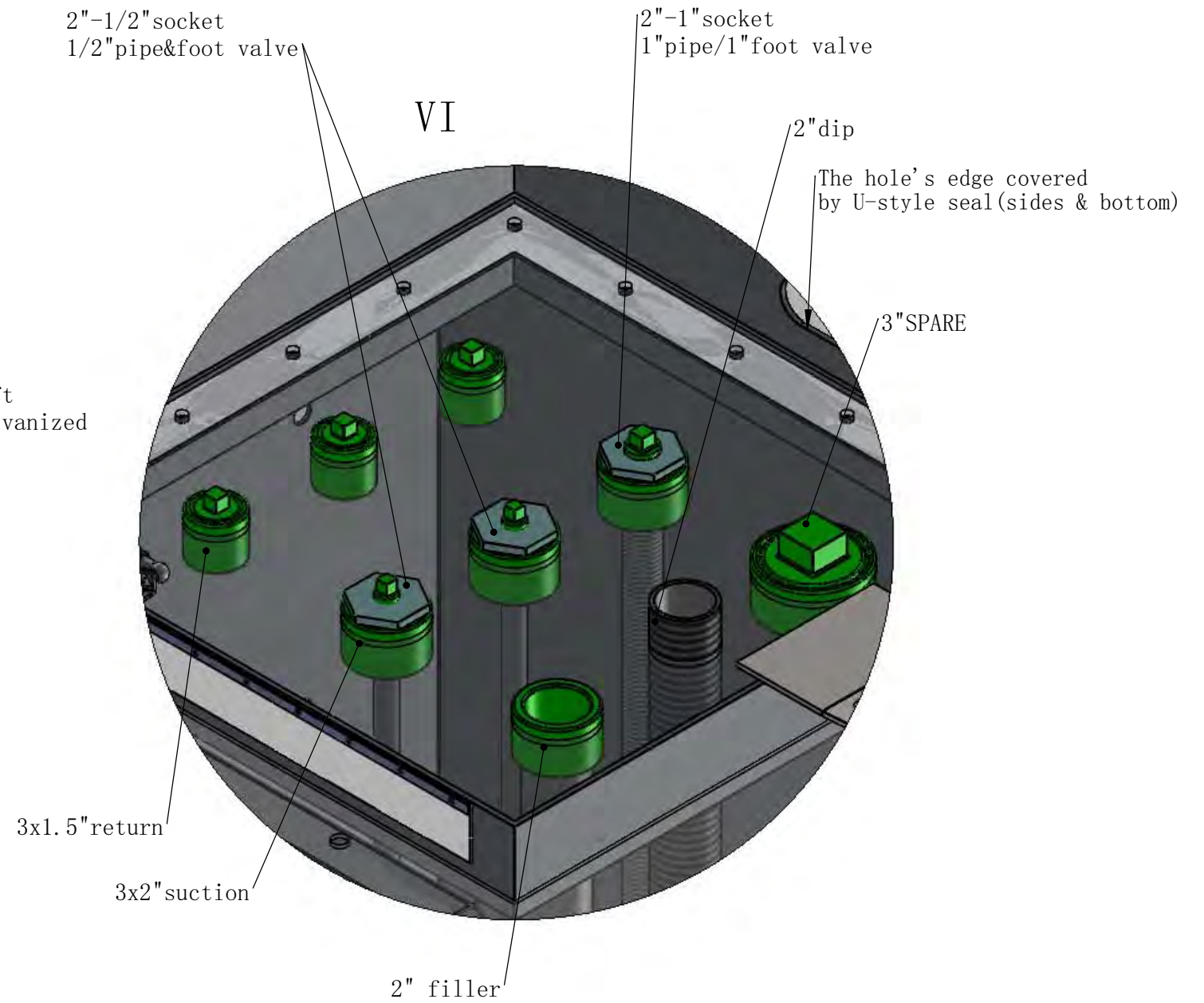

07					
06					
05					
04					
03					
02					
01					
REV:	DATE:	REVISION:	DRAWN:	CHECKED:	APPROVED:

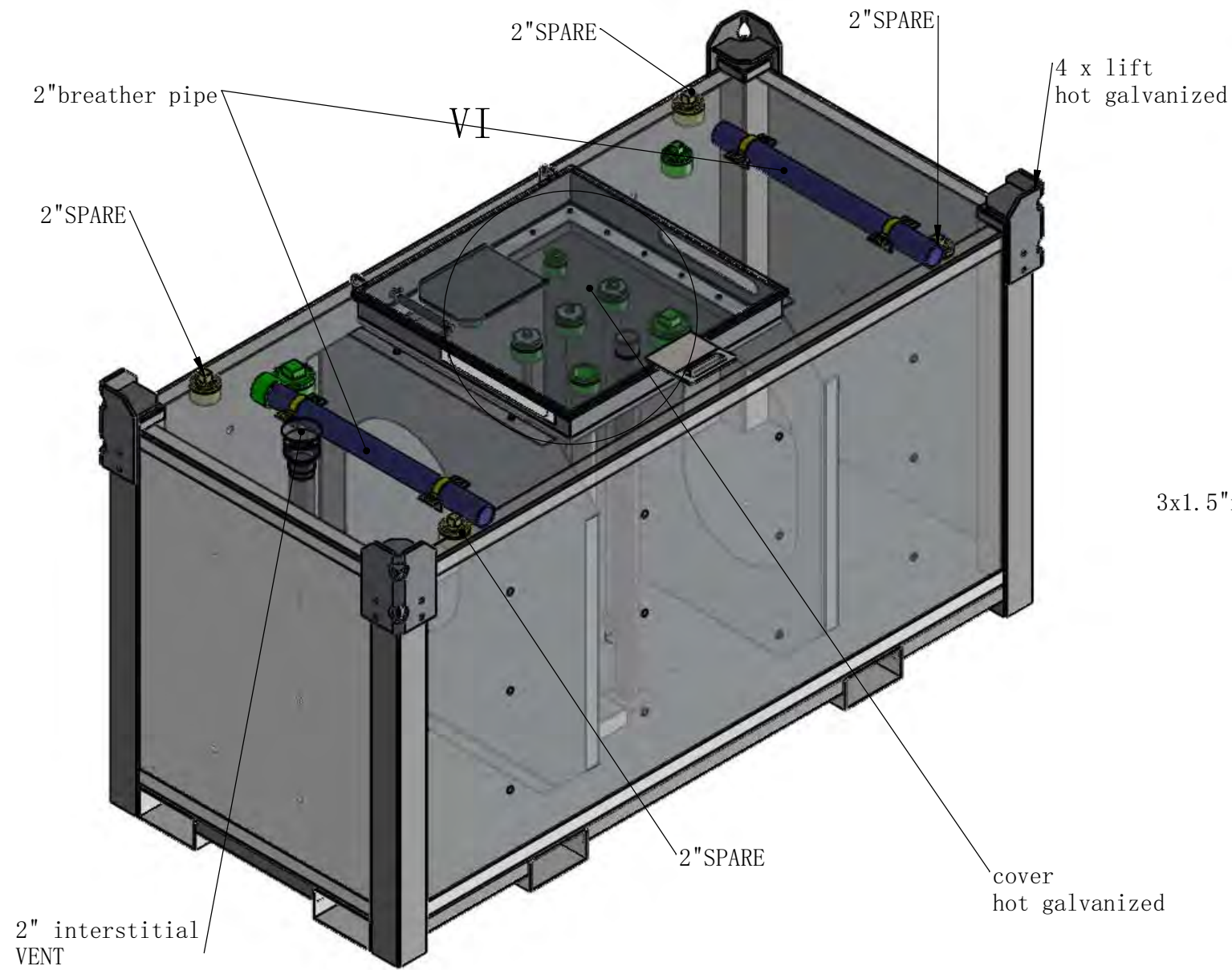

DRAWN:	DATE:	TITLE:	
	2020-06-29	CEA BOX 2250L Self Bunded Tank	
	CHECKED:	DATE:	DRAWING NO. :
CLIENT:	DATE:		REV: 01
APPROVED:	DATE:	PURCHASE ORDER NO. :	SHEET: 1 of 5
Material:			Scale: No scale
Weight:	887.62KG		A3

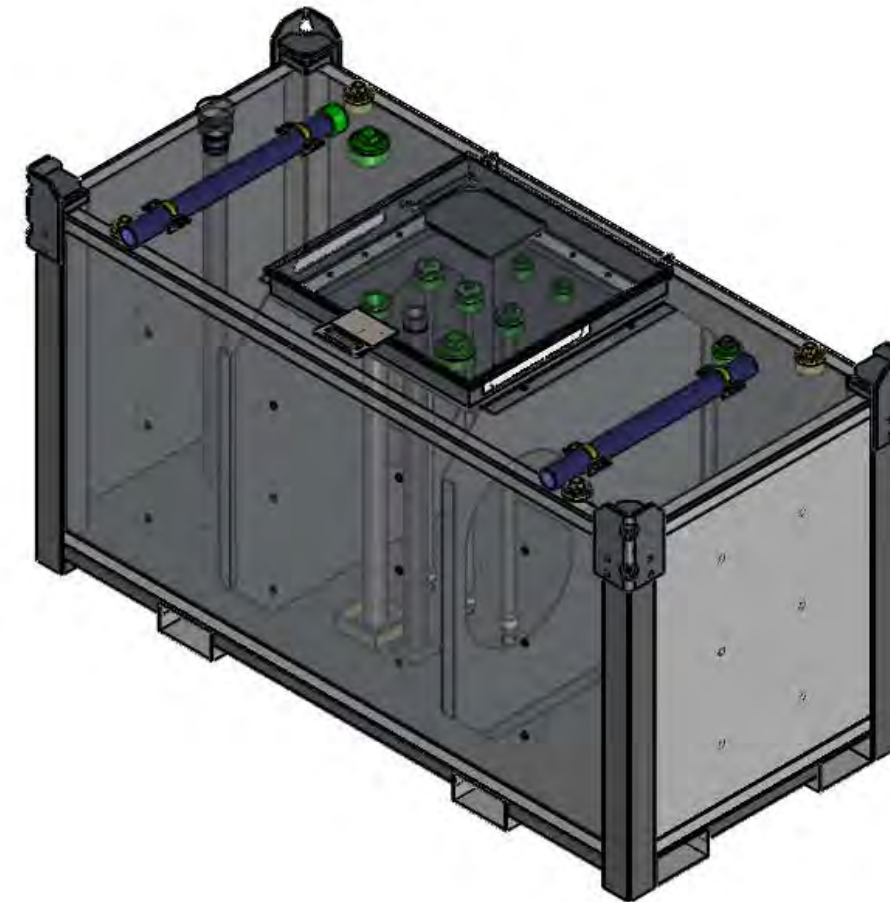
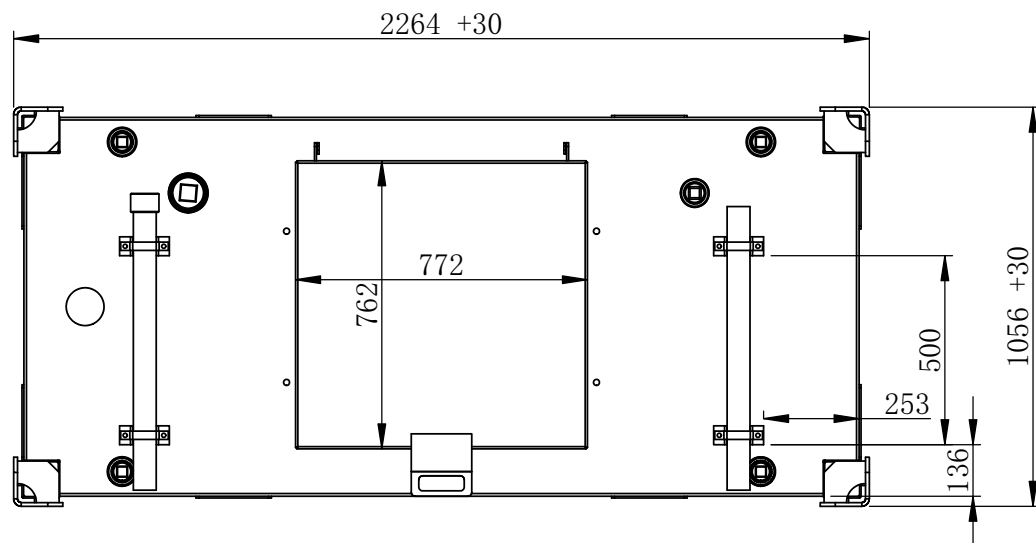
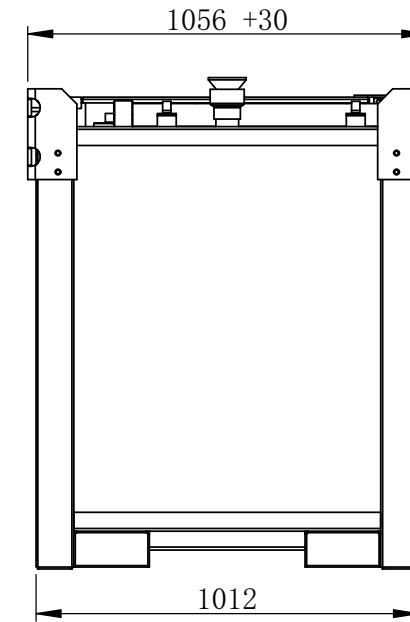
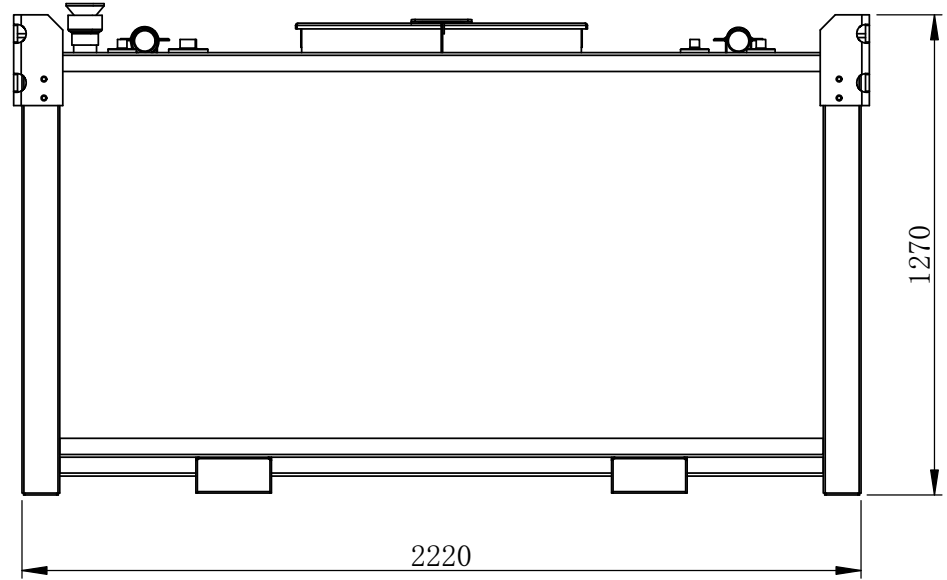

07					
06					
05					
04					
03					
02					
01					
REV:	DATE:	REVISION:	DRAWN:	CHECKED:	APPROVED:



Material:	
Weight:	887.62KG

DRAWN:	DATE:
CHECKED:	DATE:
CLIENT:	DATE:
APPROVED:	DATE:

TITLE:		REV:	A3
CEA BOX 2250L Self Bunded Tank			
DRAWING NO. :		SHEET:	Scale:
		2 of 5	
PURCHASE ORDER NO. :		No scale	

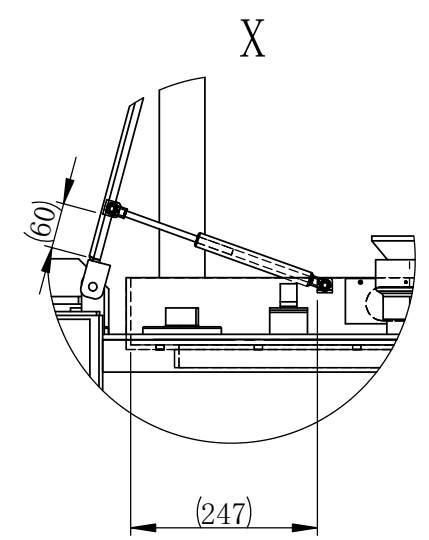
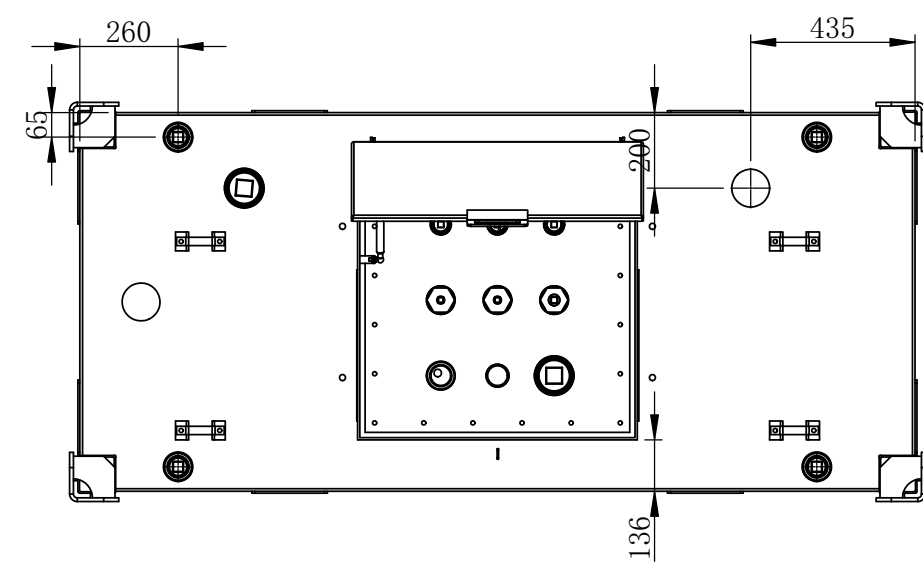
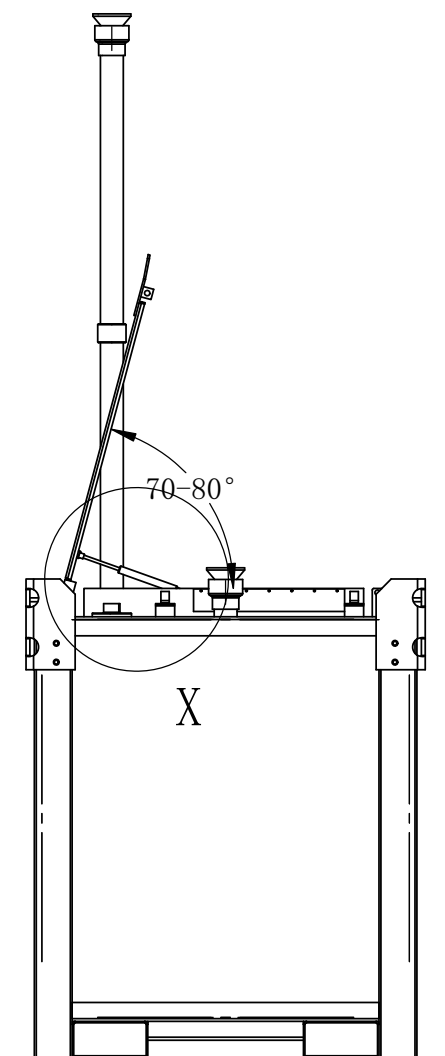
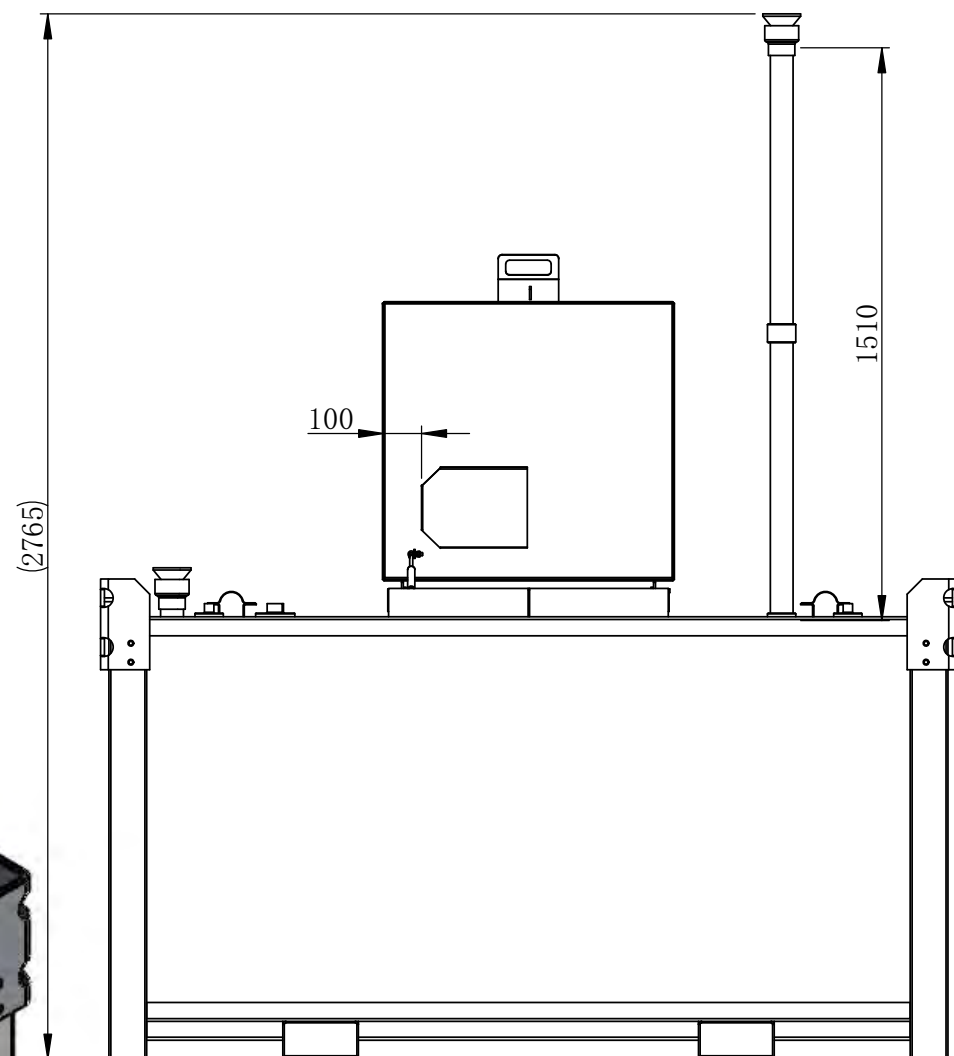
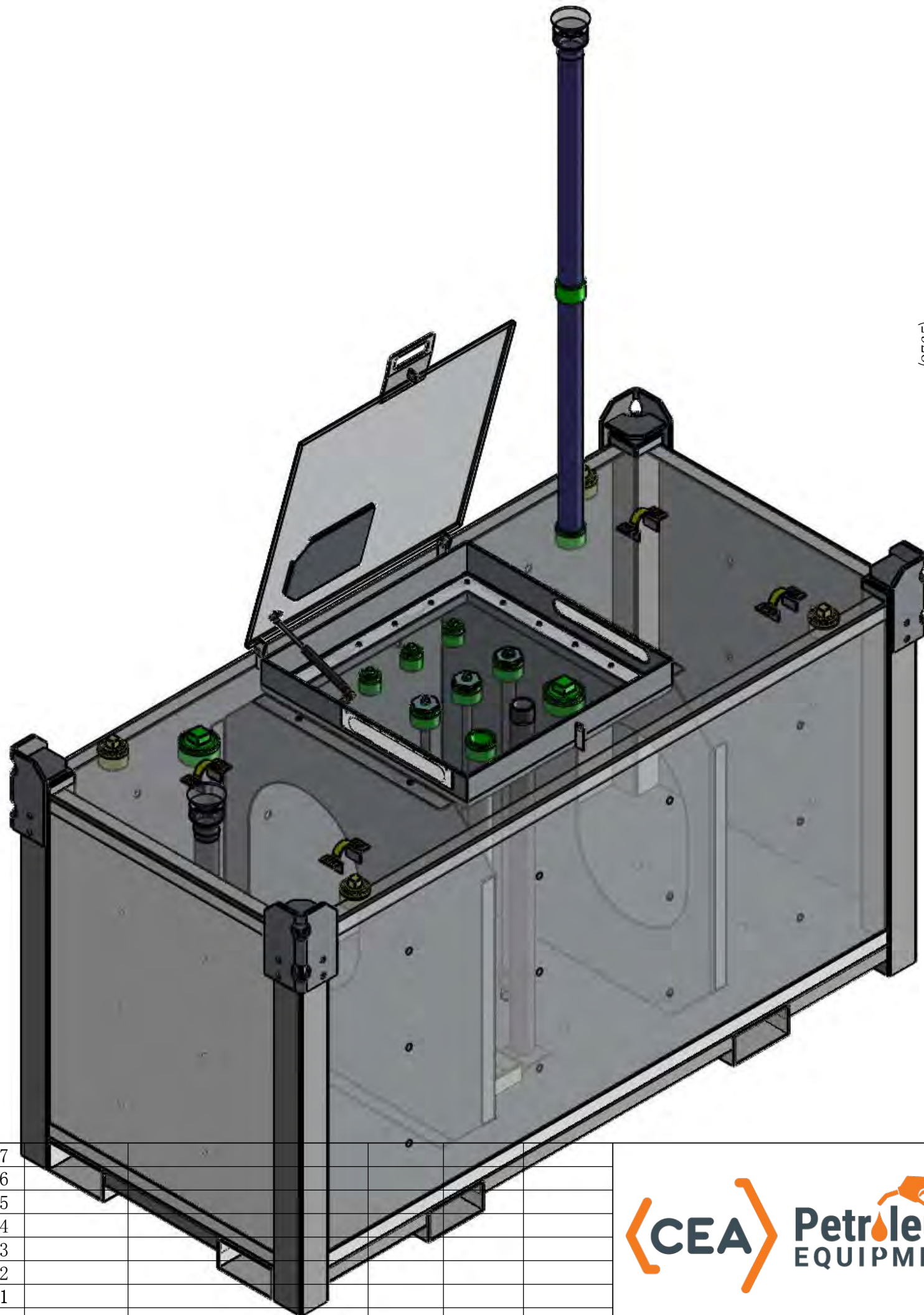

07					
06					
05					
04					
03					
02					
01					
REV:	DATE:	REVISION:	DRAWN:	CHECKED:	APPROVED:



Material:	
Weight:	888.49KG

DRAWN:	DATE:
CHECKED:	DATE:
CLIENT:	DATE:
APPROVED:	DATE:

TITLE:	CEA BOX 2250L Self Bunded Tank	
DRAWING NO. :	REV:	A3
	01	
	SHEET:	3 of 5
PURCHASE ORDER NO. :	Scale:	No scale

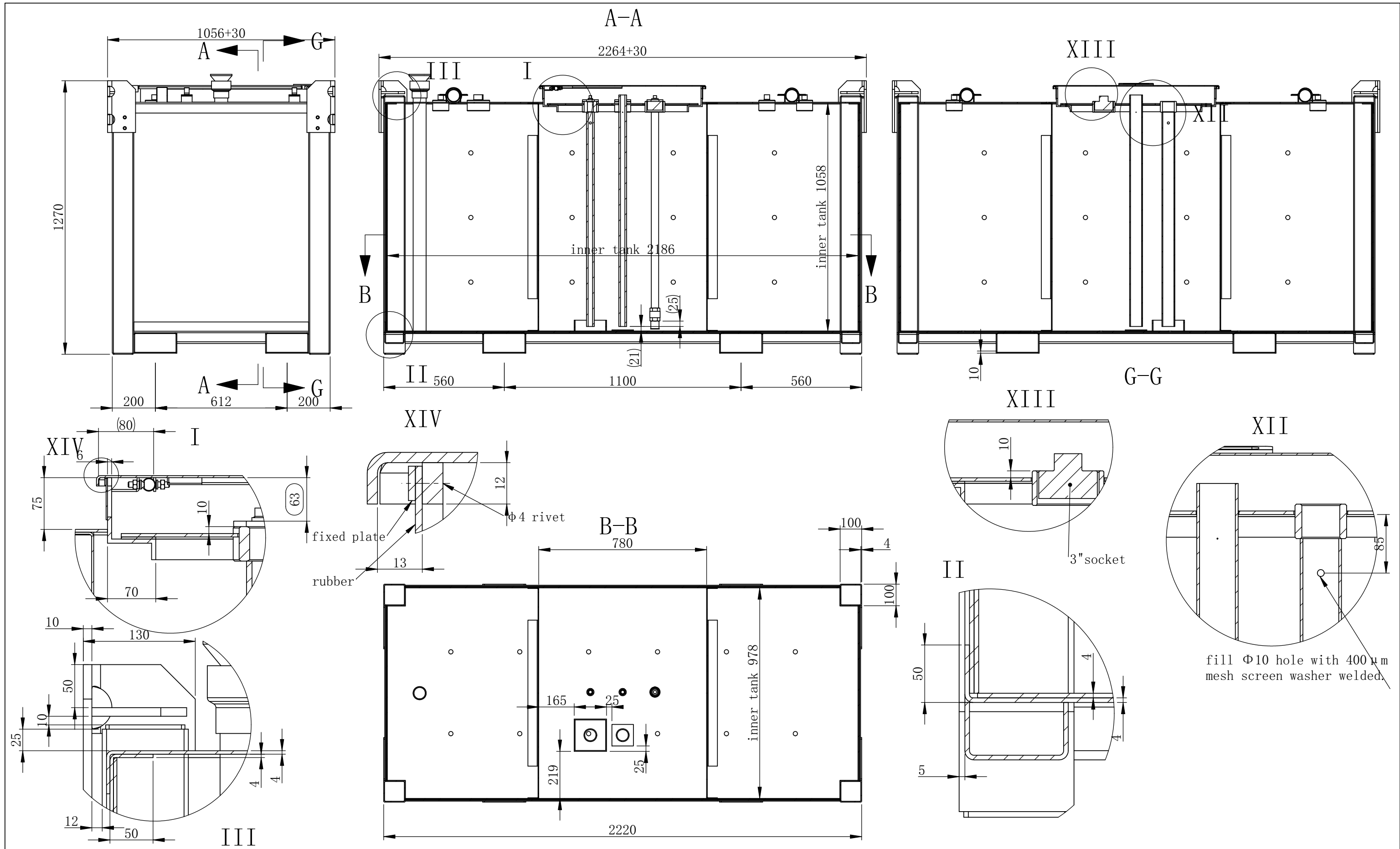

07					
06					
05					
04					
03					
02					
01					
REV:	DATE:	REVISION:	DRAWN:	CHECKED:	APPROVED:



Material:	
Weight:	884.82KG

DRAWN:	DATE:
CHECKED:	DATE:
CLIENT:	DATE:
APPROVED:	DATE:

TITLE:		REV:	A3
CEA BOX 2250L Self Bunded Tank			
DRAWING NO. :		SHEET:	Scale: \oplus - \ominus
		4 of 5	
PURCHASE ORDER NO. :		No scale	