

Tank	
TANK CONTENTS	
DESIGNED TO	AS1940 / AS1692
BUILT TO	AS1657 / AS1554.1
PLATE THICKNESS, Material	4/4 mm, Q235B
Pressue Test	35KPA
External size	1374x1086x1270mm
Internal size	1266x978x1008mm
GROSS VOLUME	1100L
SAFE FILL LEVEL	1000L
N. D. T.	Require By Client
TOTAL MASS	597.07KG

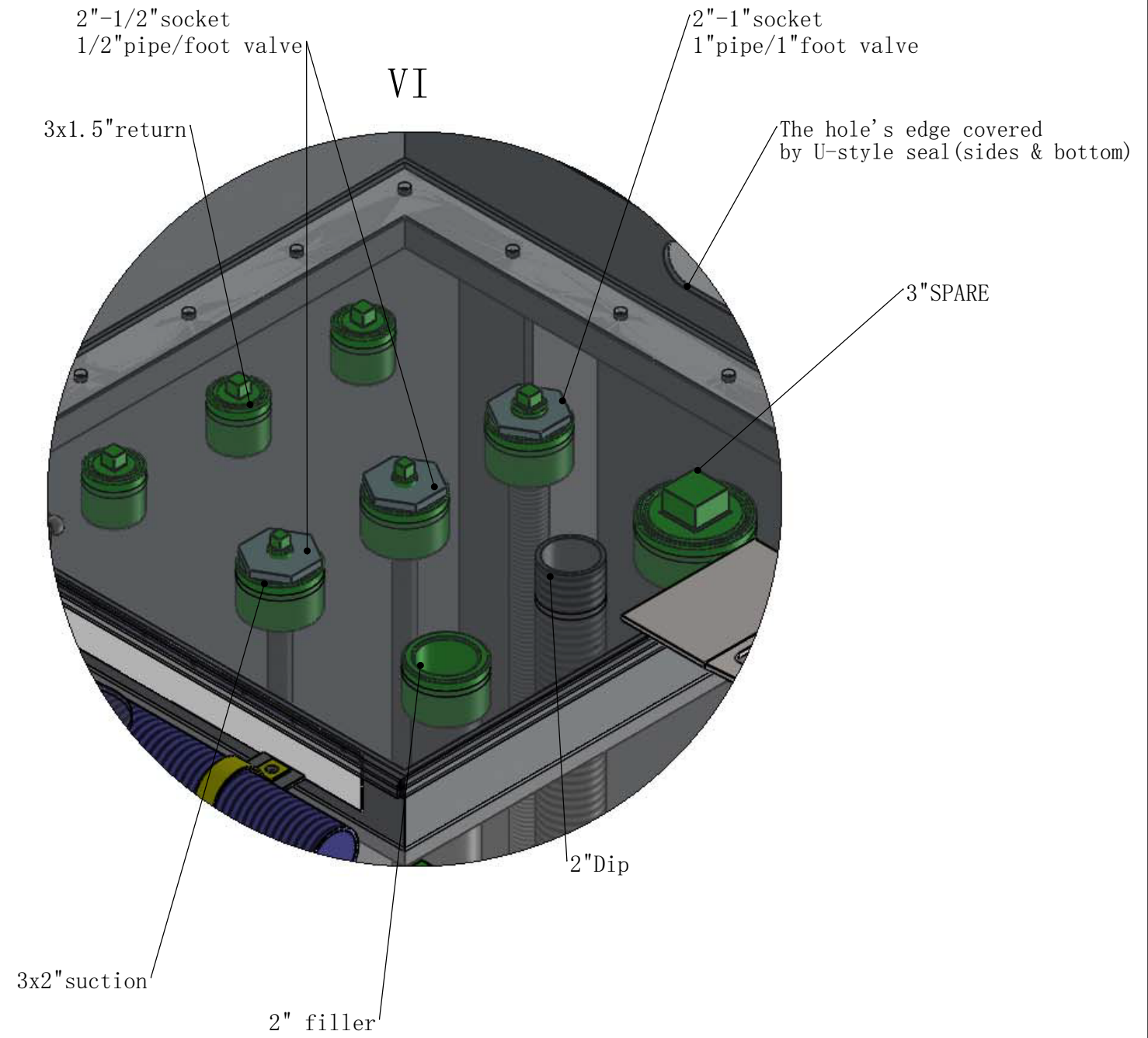

07					
06					
05					
04					
03					
02					
01					
REV:	DATE:	REVISION:	DRAWN:	CHECKED:	APPROVED:

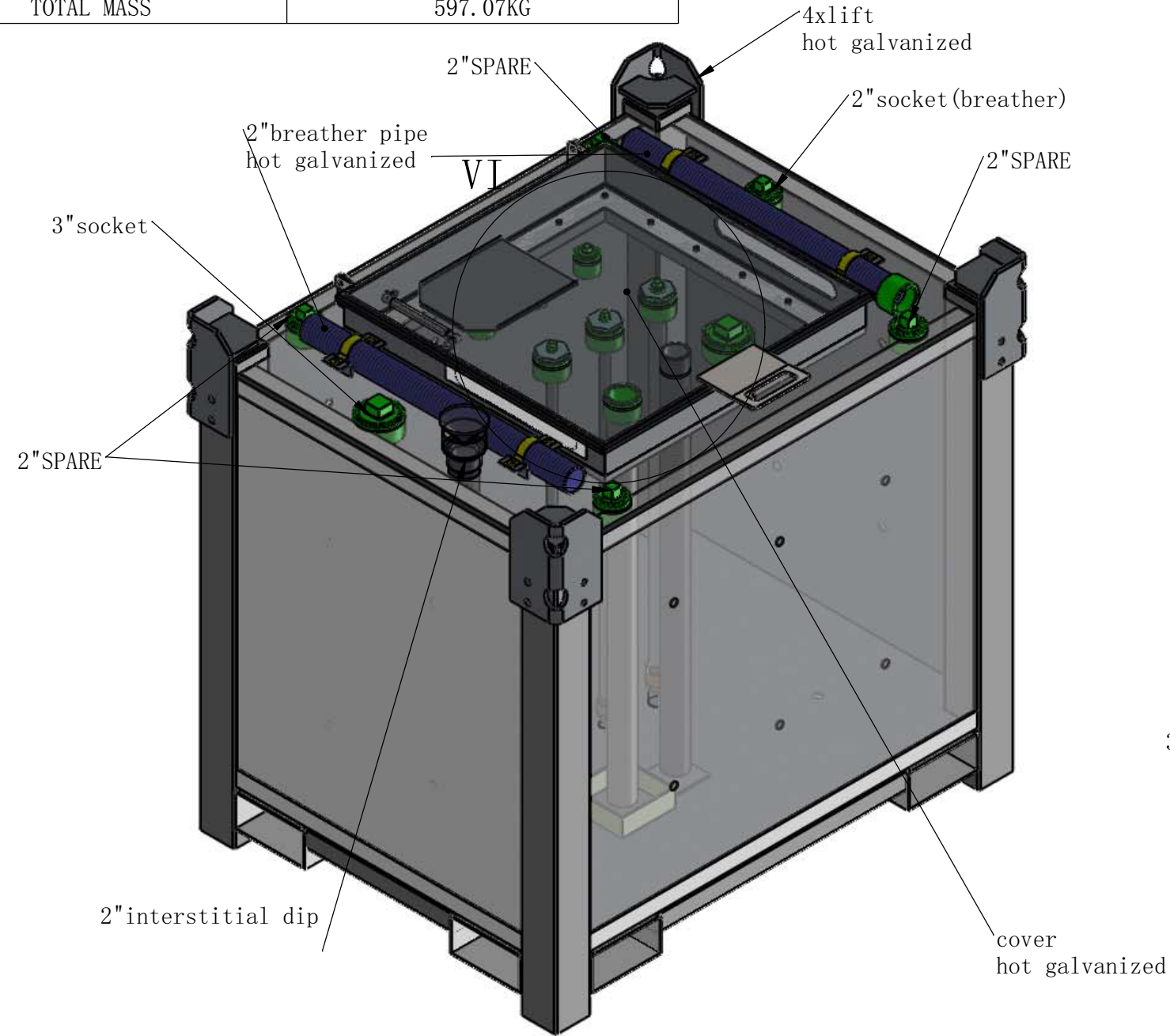

DRAWN:	DATE:	TITLE:	
	2020-06-29	CEA BOX 1100L Self Bunded Tank	
CHECKED:	DATE:	DRAWING NO. :	
			REV: 01
CLIENT:	DATE:		SHEET: 1 of 6
			A3
APPROVED:	DATE:	PURCHASE ORDER NO. :	Scale: No scale
Material:			⊕ - ▢
Weight:	597.07KG		

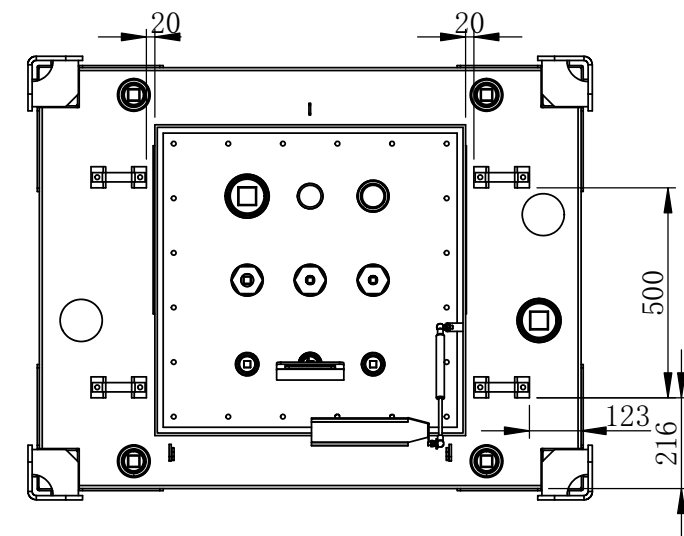
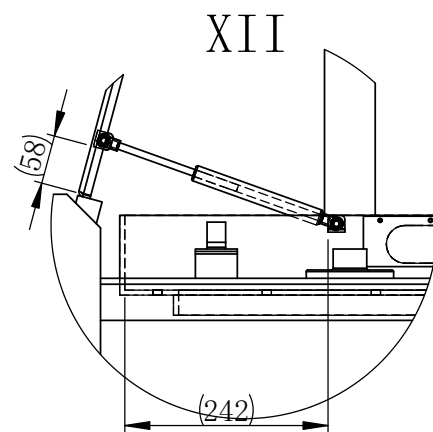
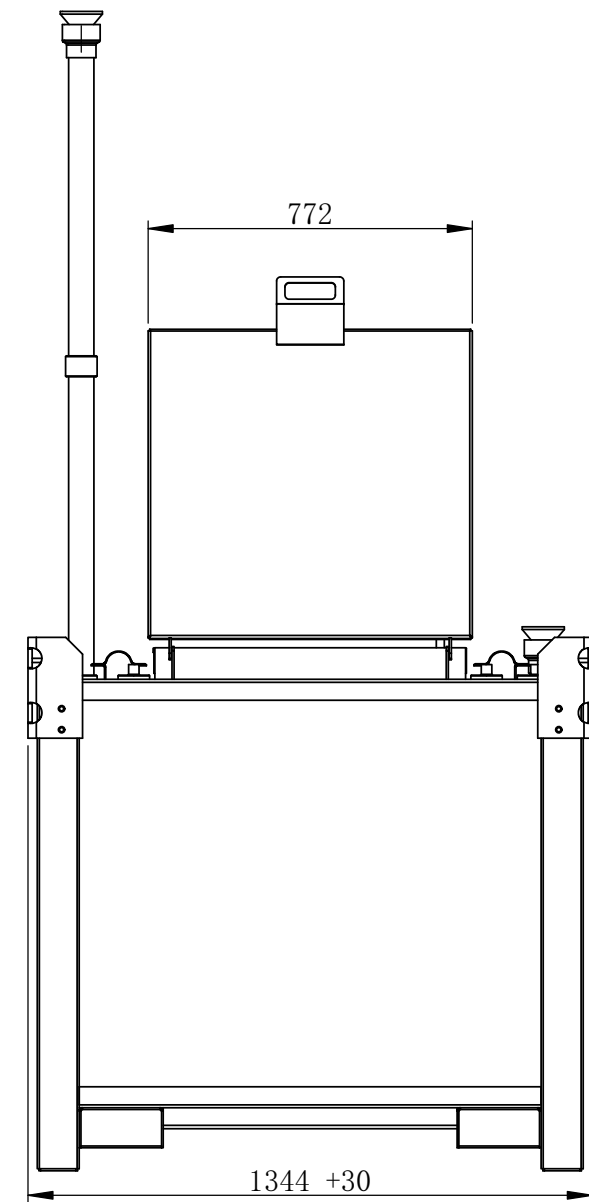
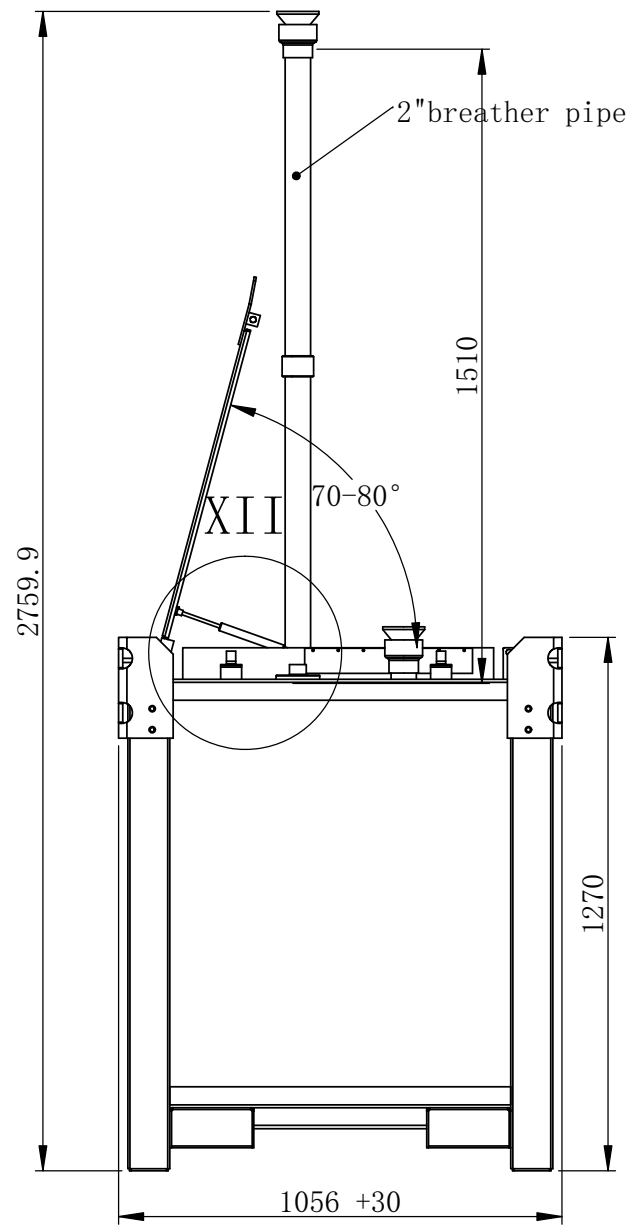
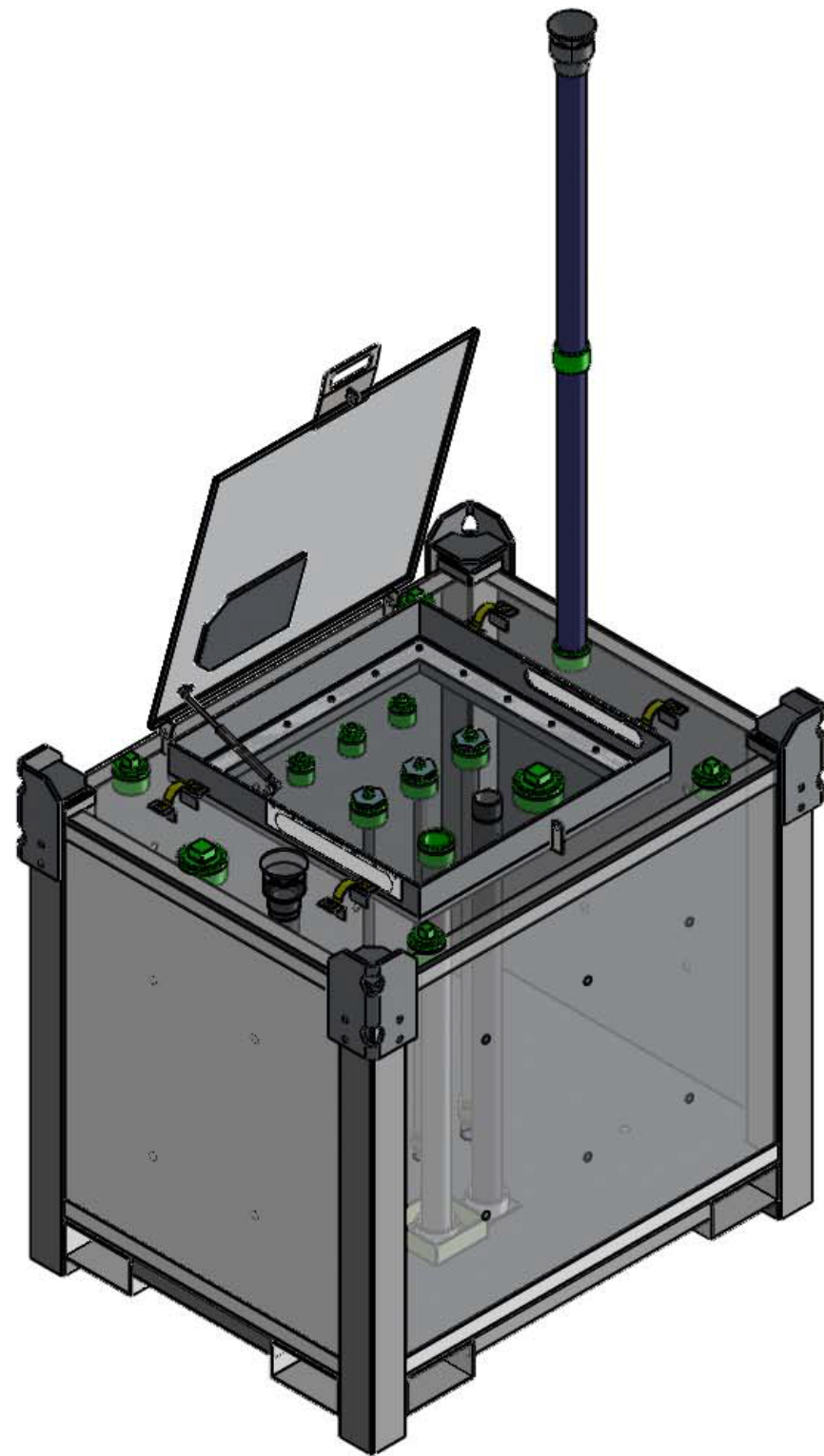

07					
06					
05					
04					
03					
02					
01					
REV:	DATE:	REVISION:	DRAWN:	CHECKED:	APPROVED:



Material:  
Weight: 597.07KG

DRAWN: DATE: 2020-06-29  
CHECKED: DATE:  
CLIENT: DATE:  
APPROVED: DATE:

TITLE: CEA BOX 1100L Self Bunded Tank  
DRAWING NO. :  
PURCHASE ORDER NO. :

REV: 01  
SHEET: 2 of 6  
Scale: No scale

A3



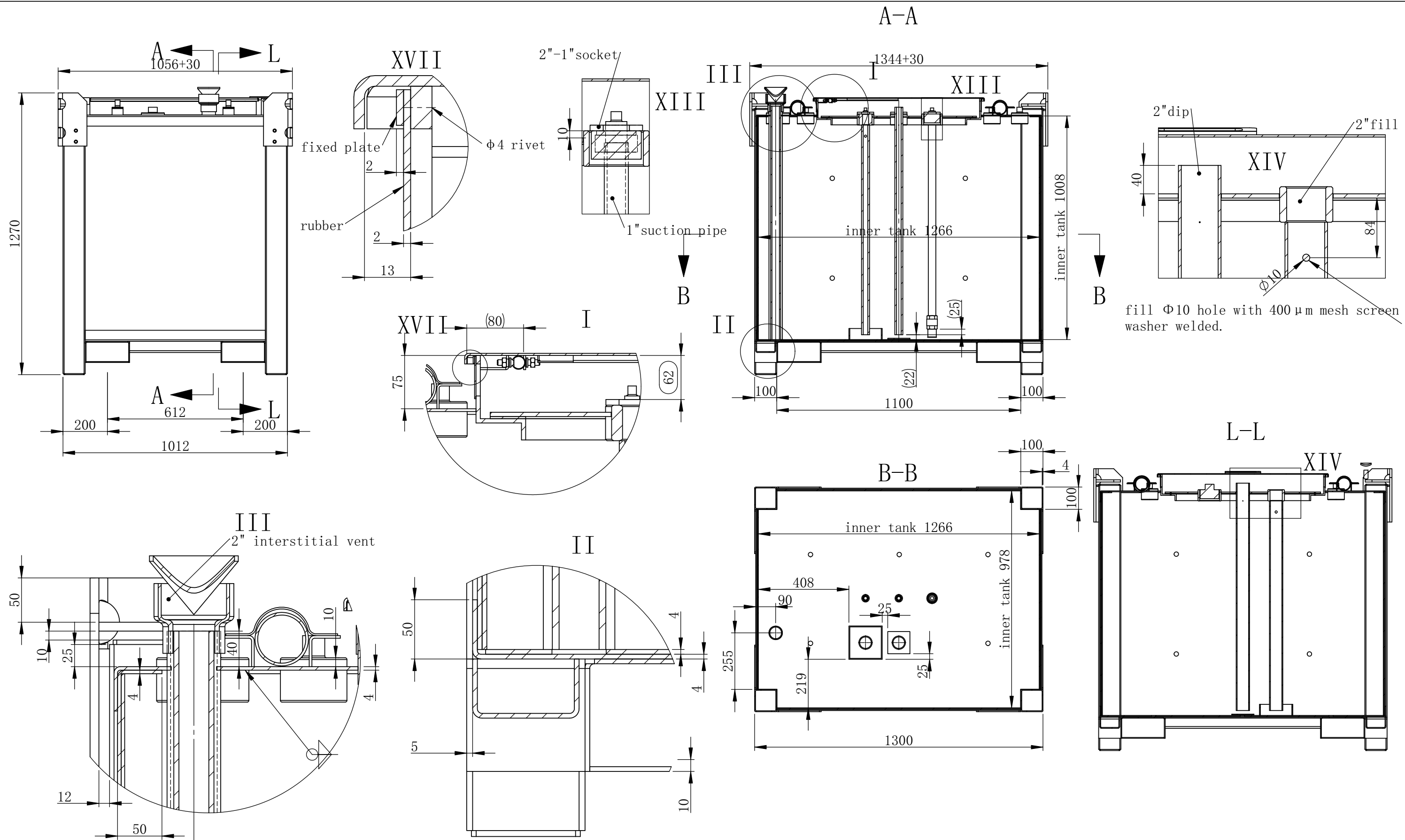

07					
06					
05					
04					
03					
02					
01					
REV:	DATE:	REVISION:	DRAWN:	CHECKED:	APPROVED:



Material:	
Weight:	597.07KG

DRAWN:	DATE:
CHECKED:	DATE:
CLIENT:	DATE:
APPROVED:	DATE:

TITLE:		REV:	A3
CEA BOX 1100L Self Bunded Tank			
DRAWING NO. :		SHEET:	Scale:
		3 of 6	
PURCHASE ORDER NO. :		No scale	

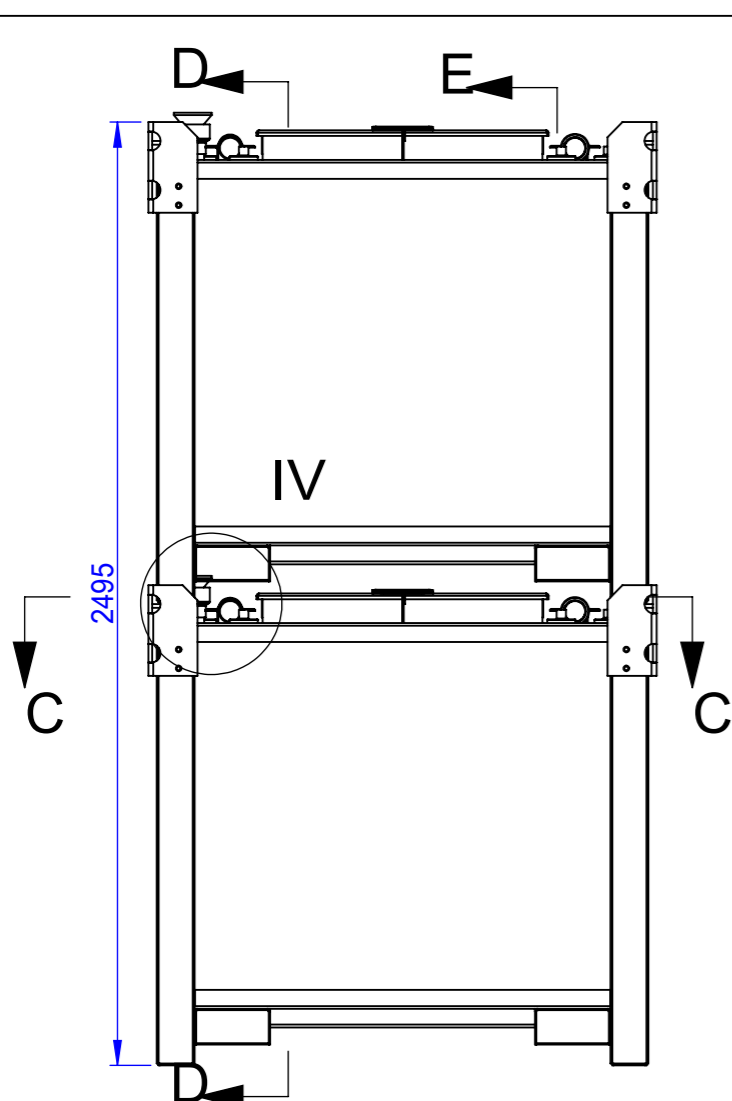

IV

D-D

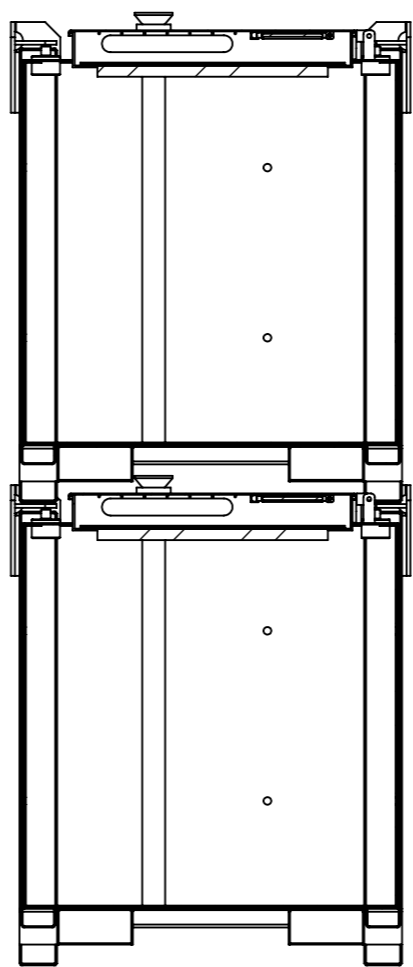

E-E

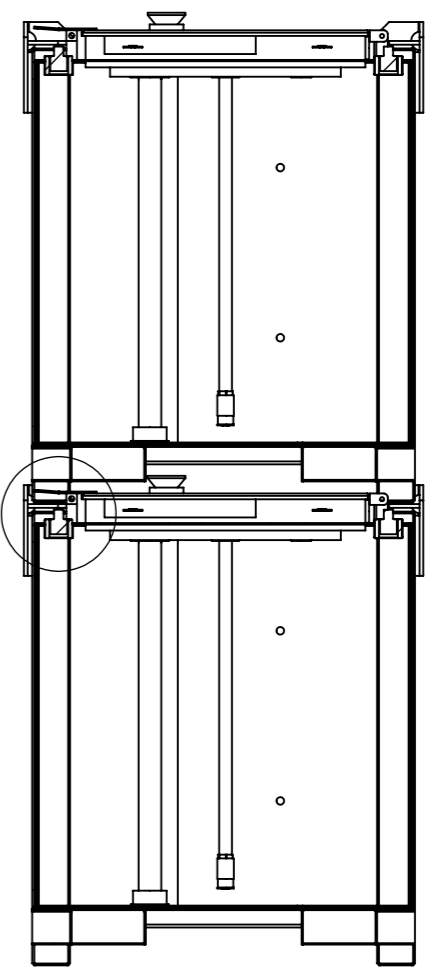

VIII

IV

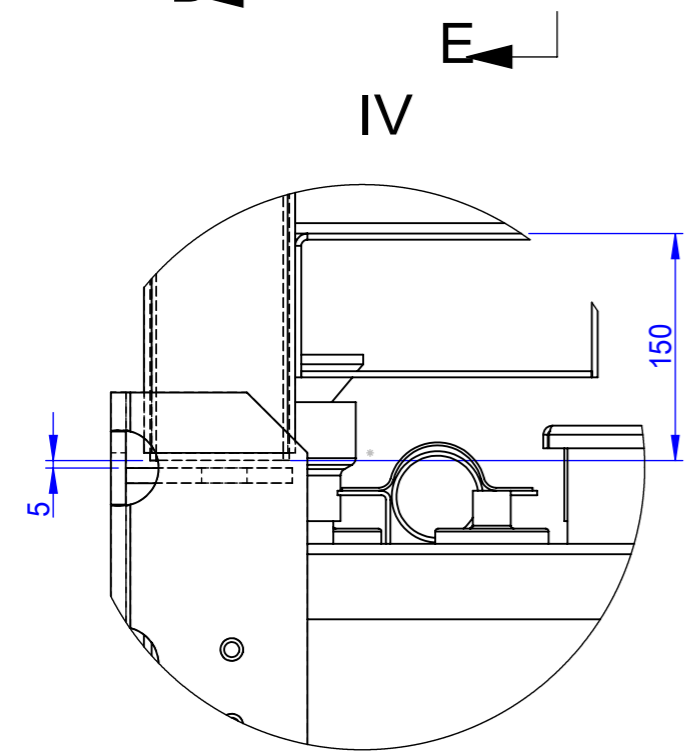

VIII

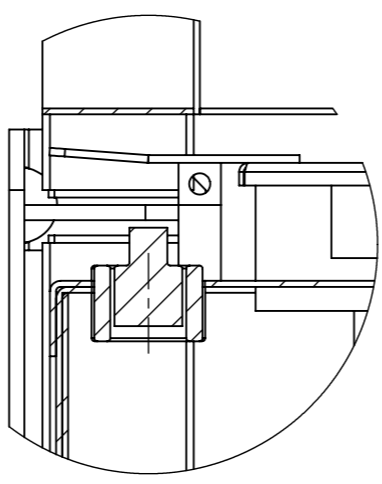

C-C

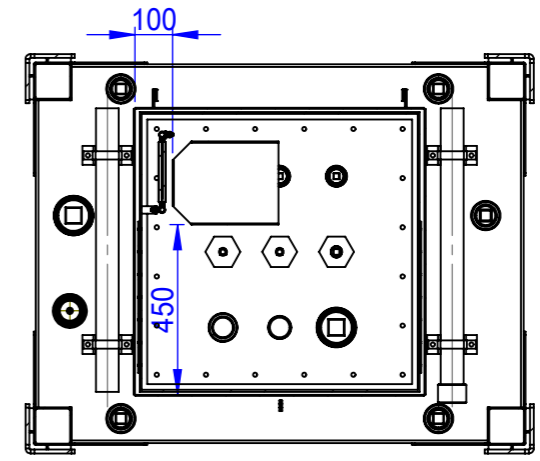

07					
06					
05					
04					
03					
02					
01					
REV:	DATE:	REVISION:	DRAWN:	CHECKED:	APPROVED:



Material:	
Weight:	1181.47KG

DRAWN:	DATE:
CHECKED:	DATE:
CLIENT:	DATE:
APPROVED:	DATE:

TITLE:		REV: 01	A3
CEA BOX 1100L Self Bunded Tank			
DRAWING NO. :		SHEET: 4 of 6	Scale: No scale
PURCHASE ORDER NO. :			