



FUEL MANAGEMENT SYSTEMS



DISPENSERS



KITS



PUMPS



METERS



NOZZLES

MCBOX

FEATURES

- ACCESS CONTROL
- SUITABLE FOR ANY PUMP
- PULSE METER INPUT
- EASY TO INSTALL
- MULTI USERS
- COMPATIBLE WITH SSM2018 SOFTWARE

The PIUSI MCBOX is a practical electronic multi-user control panel that allows to manage and control an existing pump, pulse meter and nozzle. Integrated with the SELF SERVICE MANAGEMENT 2018, it grants the possibility to download all the transactions.



PERFORMANCE

120

USERS

AC/DC
VOLTAGE

POWER

255

TRANSACTION MEMORY



MCBOX



PACKAGING

CODE	WEIGHT		PACKAGING		
	KG	LBS	MM	INCH	PCS/BOX
F139800C	5	11	300X300X180	11,8X11,8X7	1
F1398005B	5	11	300X300X180	11,8X11,8X7	1
F1398001B	6	13	300X300X180	11,8X11,8X7	1
F1398002B	6	13	300X300X180	11,8X11,8X7	1



FILTRATION



TANK MONITORING



HOSE REEL



ACCESSORIES



MERCHANDISE



AIR



ANTIFREEZE



AdBlue®



BIODIESEL



DIESEL



FOOD



GASOLINE



GREASE



KEROSENE



OIL



WATER



WINDSCREEN

CONNECTION SCHEME



PUMP CONTROL



PULSE METER INPUT



TANK LEVEL INDICATOR



NOZZLE SWITCH WITH A60



IN THE BOX

- MCBOX UNIT
- INSTRUCTION MANUAL

DETAILS



SHUTTER



SSM 2018 SOFTWARE (pag. 42)



EASY ACCESS TO CONNECTION

DIMENSIONS

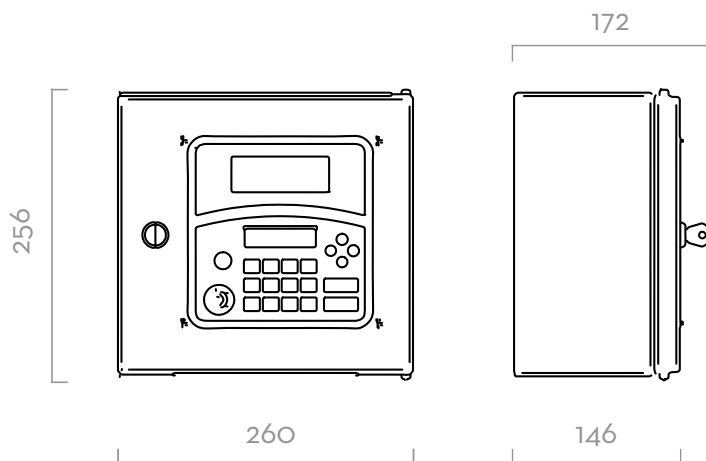

Dimensions expressed in millimeters



TECHNICAL DATA

CODE	DESCRIPTION	FLUIDS TYPE	USERS	VOLTAGE			SSM 2018 SOFTWARE
				AC V./HZ	POWER WATT	AMP. MAX. (load motor)	
F139800OC	MCBOX_230V50/60HZ_80U_IBP	A Ad B D F G G K O W W	80	230/50	35	6,5	OPTIONAL
F1398005B	MCBOX_230V50/60HZ_120U_IBP	A Ad B D F G G K O W W	120	230/50	35	6,5	OPTIONAL
F1398001B	MCBOX_12V_120U_IBP	A Ad B D F G G K O W W	120	12	10	50	OPTIONAL
F1398002B	MCBOX_24V_120U_IBP	A Ad B D F G G K O W W	120	24	10	25	OPTIONAL

MCBOX