



THE BEST BRANDS, THE BEST PRODUCTS

Your one stop shop for all sauna and steam needs.

2021

saunas.com
(888) 503-8157
info@saunas.com
6700 N Linder # 152-180
Meridian, Idaho 83646

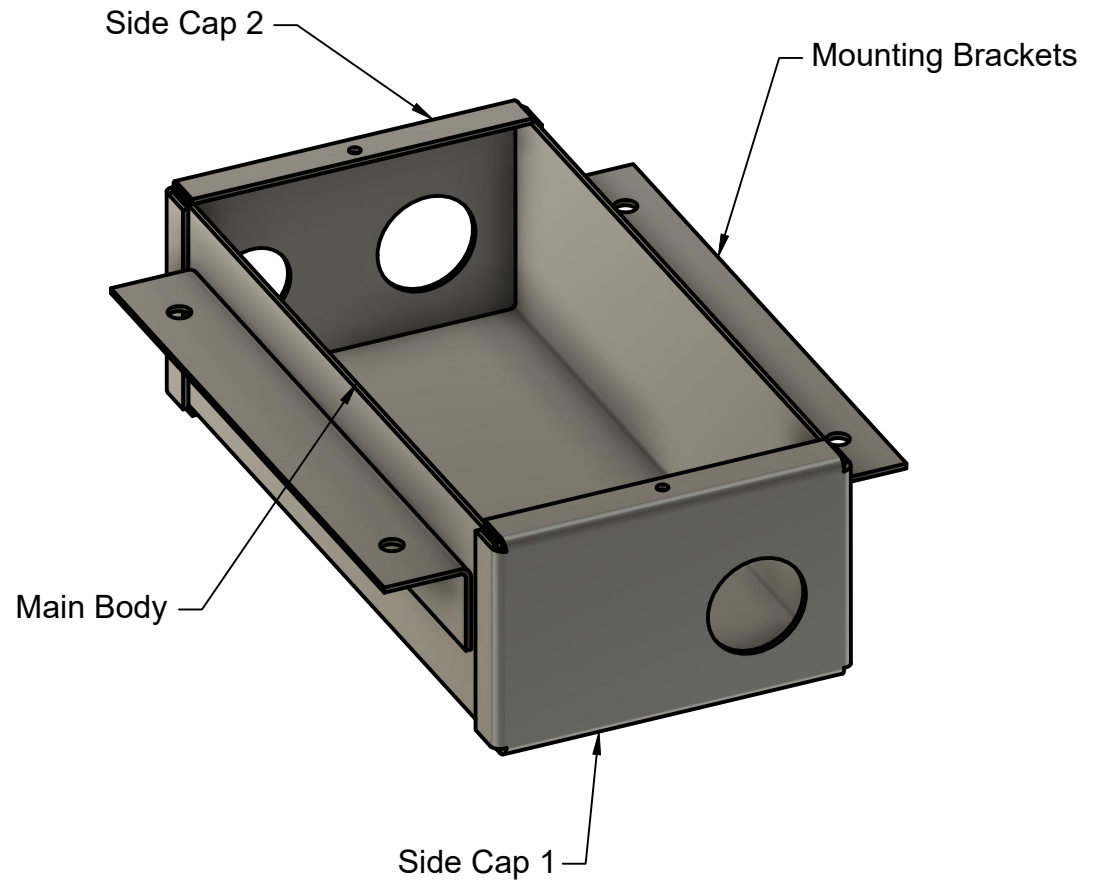
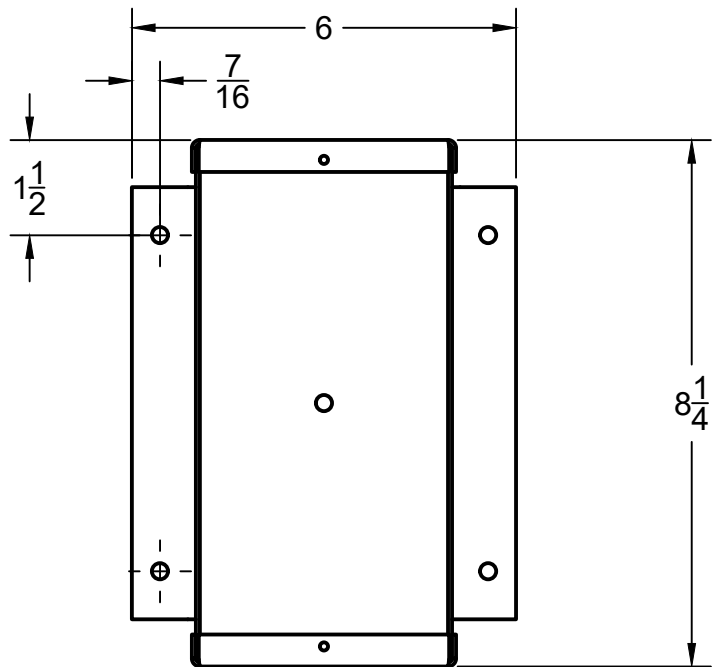
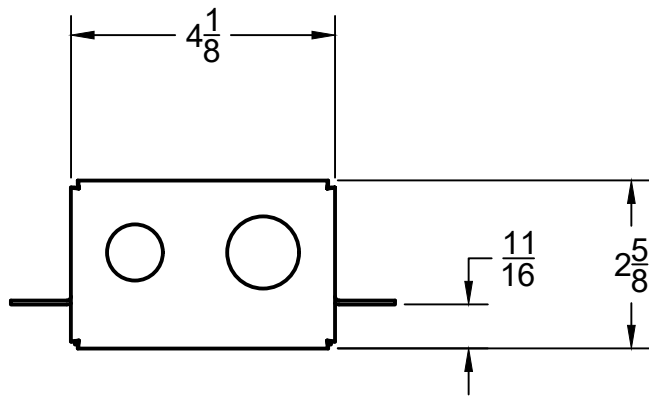

ALL F & H Control TYPES

Units: Inches Fractional and Decimal Tolerances : - $\frac{1}{16}$ "	Small Control Box		
	7/29/2020	Scandia Manufacturing	REV
	1:1.5	DRAWN by William Buchanan	SHEET 1/5

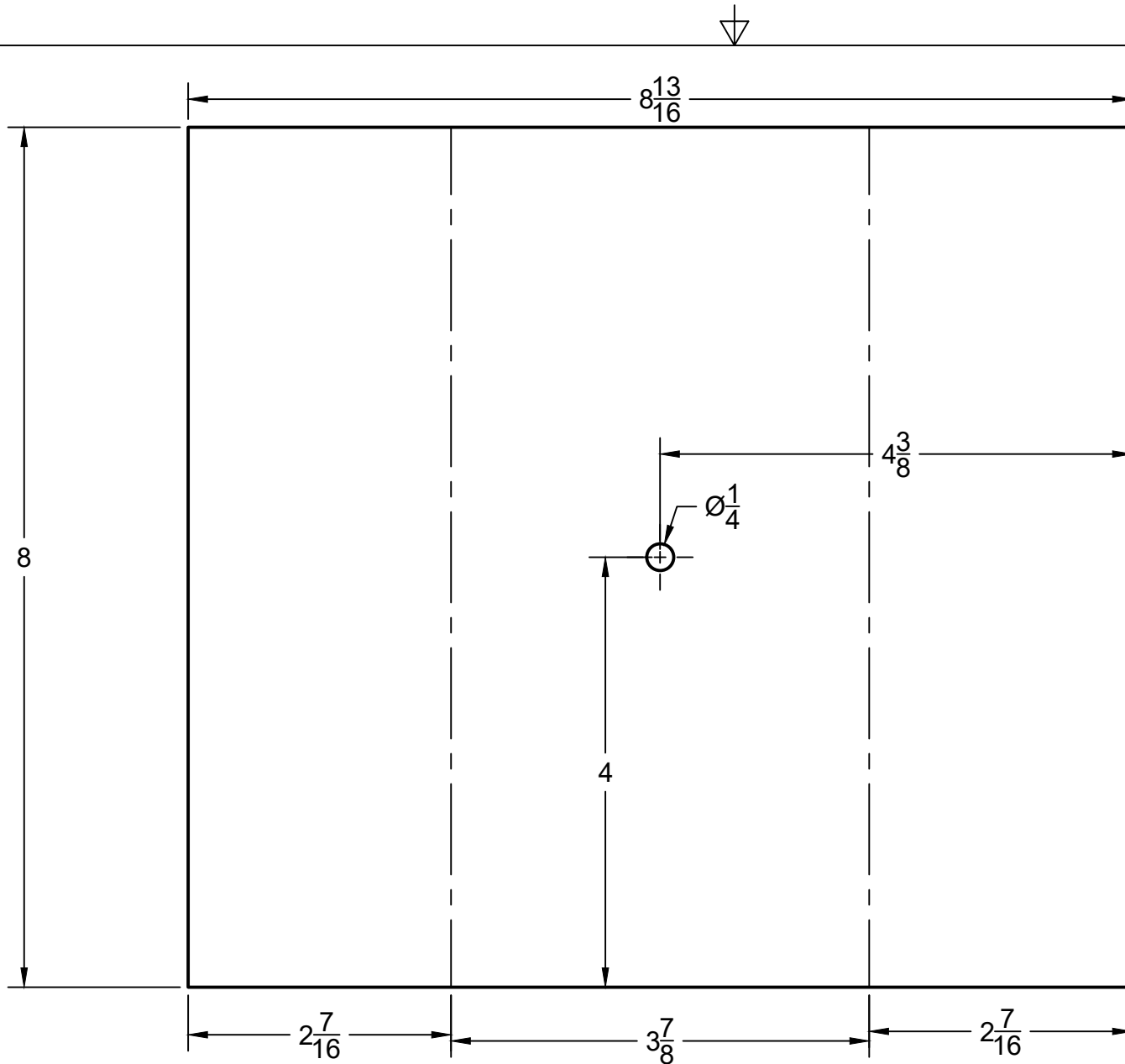

Units: Inches Fractional and Decimal Tolerances : - $\frac{1}{16}$ "	Small Control Box, Body		
	7/29/2020	Scandia Manufacturing	REV
	1:1.5	DRAWN by William Buchanan	SHEET 2/5

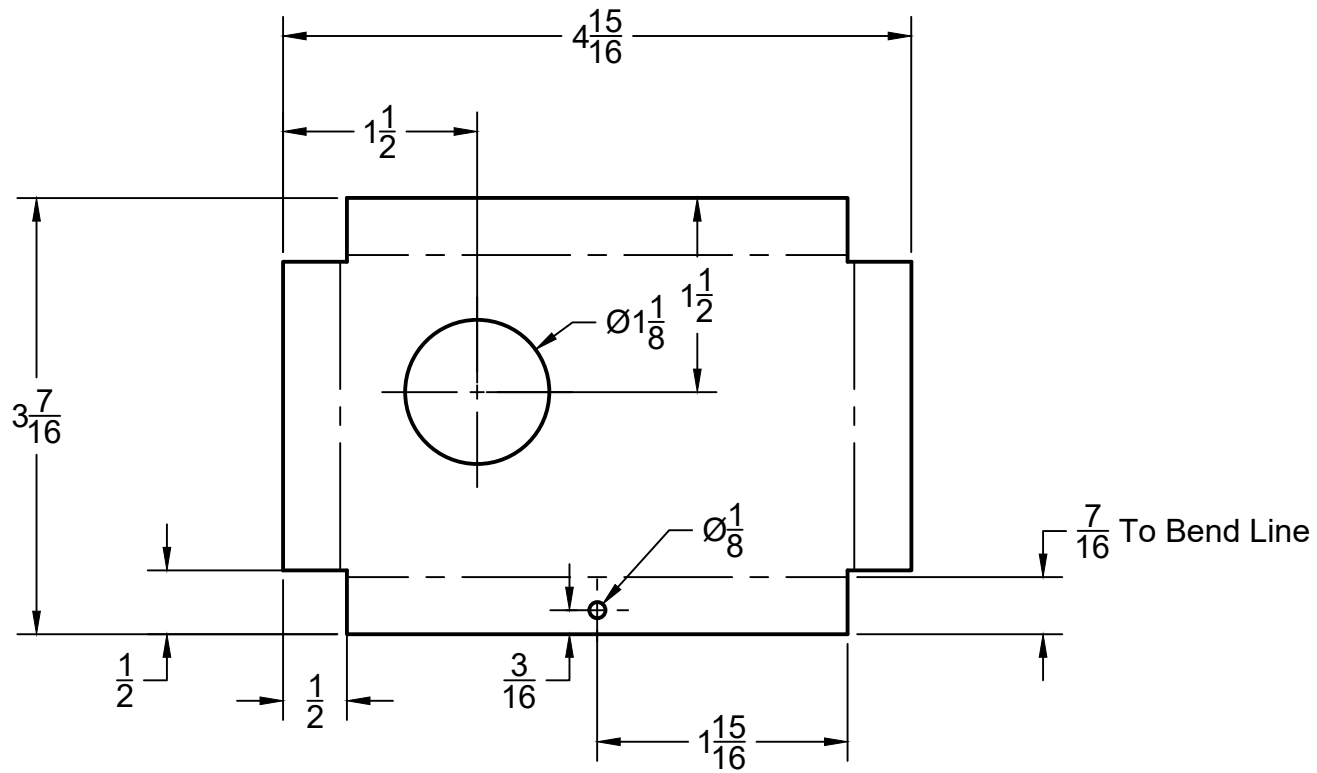

Units: Inches Fractional and Decimal Tolerances : $-\frac{1}{16}$ "	Small Control Box, Side Cap 1		
	7/29/2020	Scandia Manufacturing	REV
	1:2	DRAWN by William Buchanan	SHEET 3/5

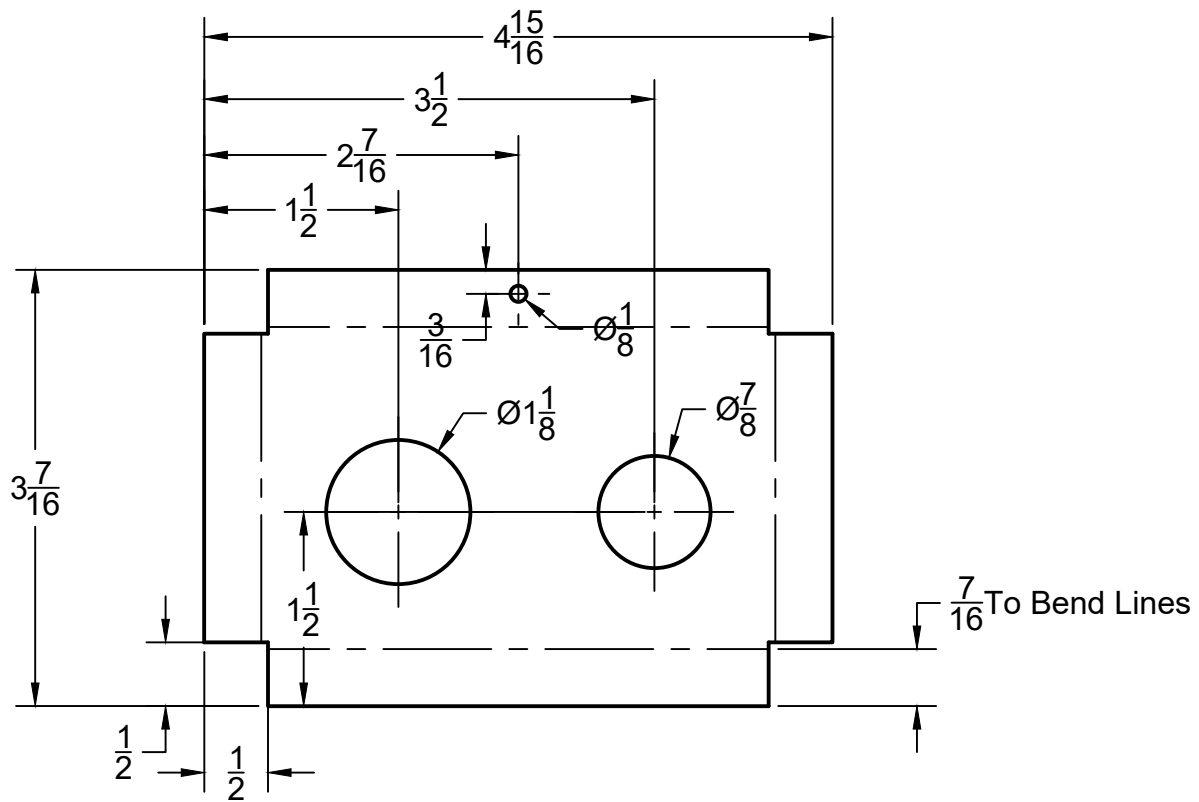

Units: Inches Fractional and Decimal Tolerances : $-\frac{1}{16}$ "	Small Control Box, Side Cap 2		
	7/29/2020	Scandia Manufacturing	REV
	1:1.5	DRAWN by William Buchanan	SHEET 4/5

