



SCANDIA
MANUFACTURING

(877) 467 2862

www.scandiamfg.com

customerservice@scandiamfg.com

372 S Eagle Rd #341 Eagle, Idaho 83616

Project Name	4 Person Sauna Kit
Room Type	SAUNA ROOM

Scandia Manufacturing

Shipping information confirmation

Our Sauna's and our Steam rooms will come in a crate. The crate size will vary based on the number of rooms and room sizes, but are on average 4' x 4' x 7', around 1000 pounds. We will also be shipping either sauna heaters or steam equipment, these will arrive wrapped safely on a pallet.

Upon Delivery please inspect the freight for obvious outward damages before signing the delivery receipt. If there are damages then notify the delivery driver to notate the damages. If this is not done, Scandia cannot be held responsible for damaged materials.

CUSTOMER CHECKLIST FOR SAUNA INSTALLATION PROJECT:

Dear Customer,

Please review the list below to ensure rooms are prepared correctly. These items need to be done before you can install your sauna:

- Interior ceiling height is 7'0" from your finish floor to the plywood on ceiling _____
- Room must be insulated on walls and ceiling (Minimum R13 in walls, R19 in ceiling) _____
- All interior walls and ceiling must be covered with 3/4" plywood. Furring strips are not acceptable _____
- Interior room dimension must match the sauna kit layout _____
- Door rough opening must match sauna kit layouts _____
- Rough opening must be wrapped with wood studs _____
- There must be a power source within 50 ft from the room/project site _____
- Electrical (for heater) is in place per heater installation instructions and sauna kit layouts _____
- Control Box has been mounted and power run from it to the heater
- In-Take VENT required underneath the heater. Vent cover (4" x 10") provided by GC/Owner. _____
- Sprinkler head is in place and is the correct heat rating _____
- Sauna flooring must be concrete, tile or any other waterproof surface. Scandia offers TruTile or Cedar Duckboard to sit on top of this floor _____
- Sauna floor must be level and NOT have a drain _____
- ALL AND ANY CODE, STATUTES, LICENSES, ETC, HAVE BEEN CONSIDERED BY THE GC/OWNER REGARDING THIS PROJECT _____
- All Electrical shall be completed by others _____

Example of a Sauna Room prepped for Install!

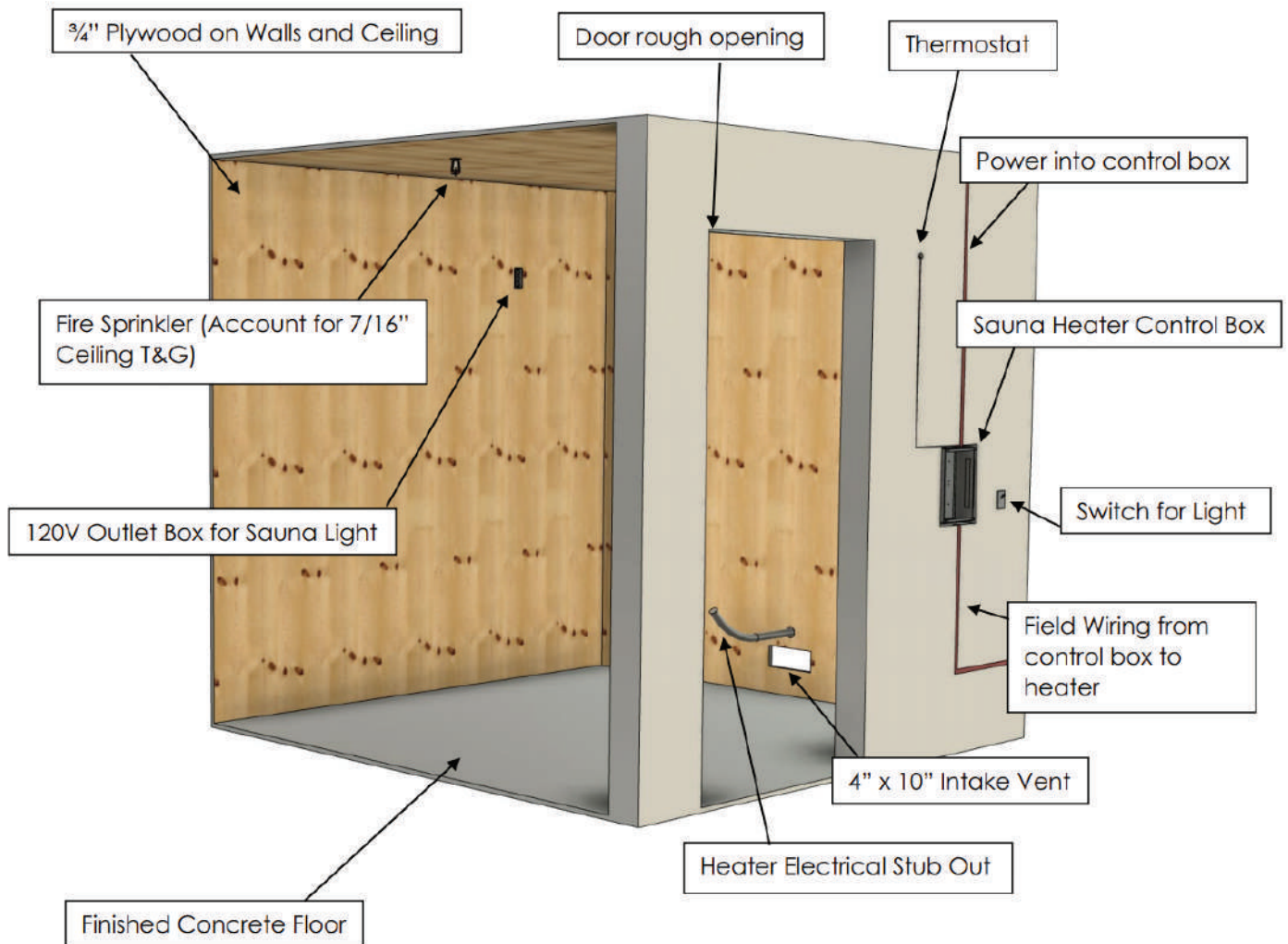

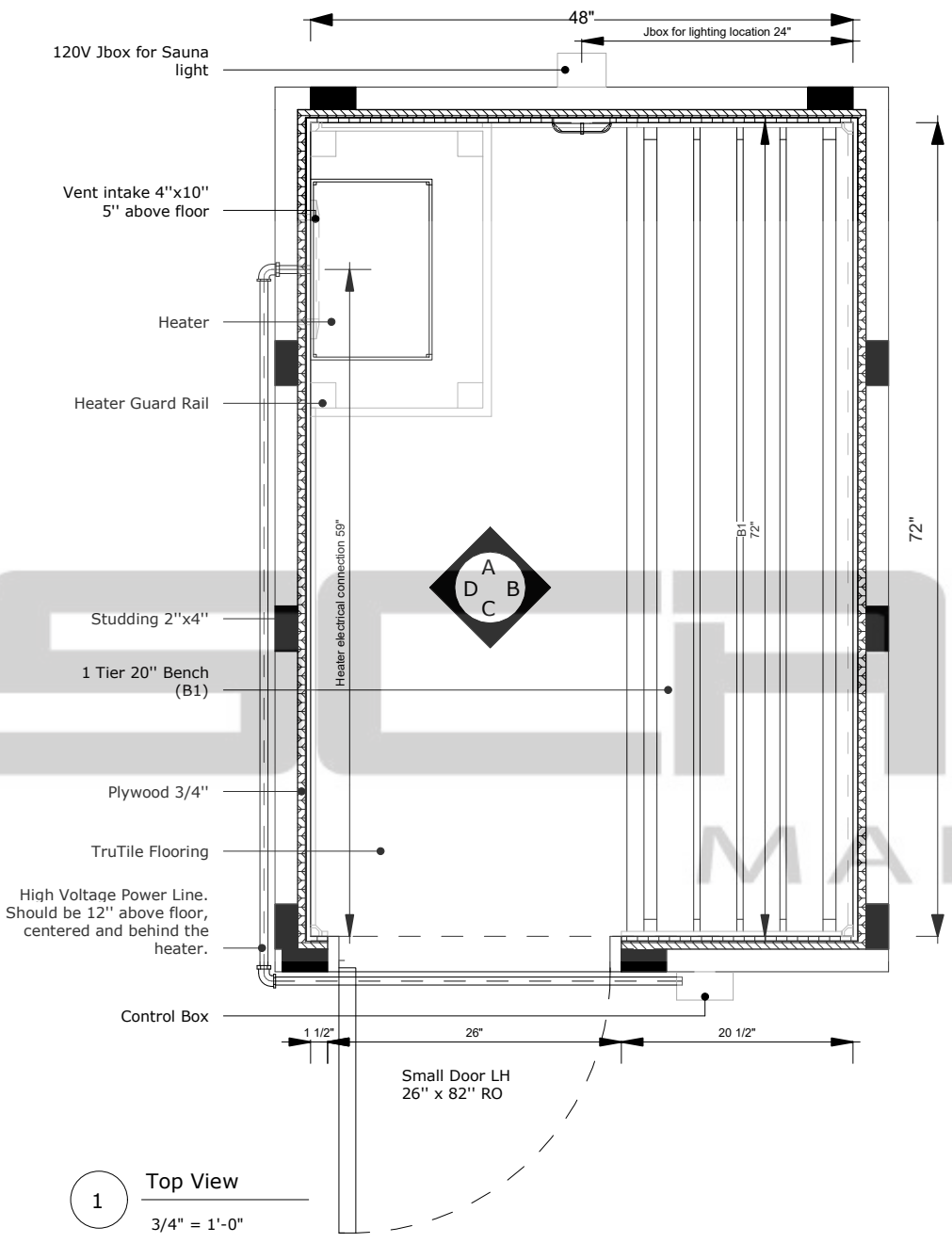

1 Top View
3/4" = 1'-0"

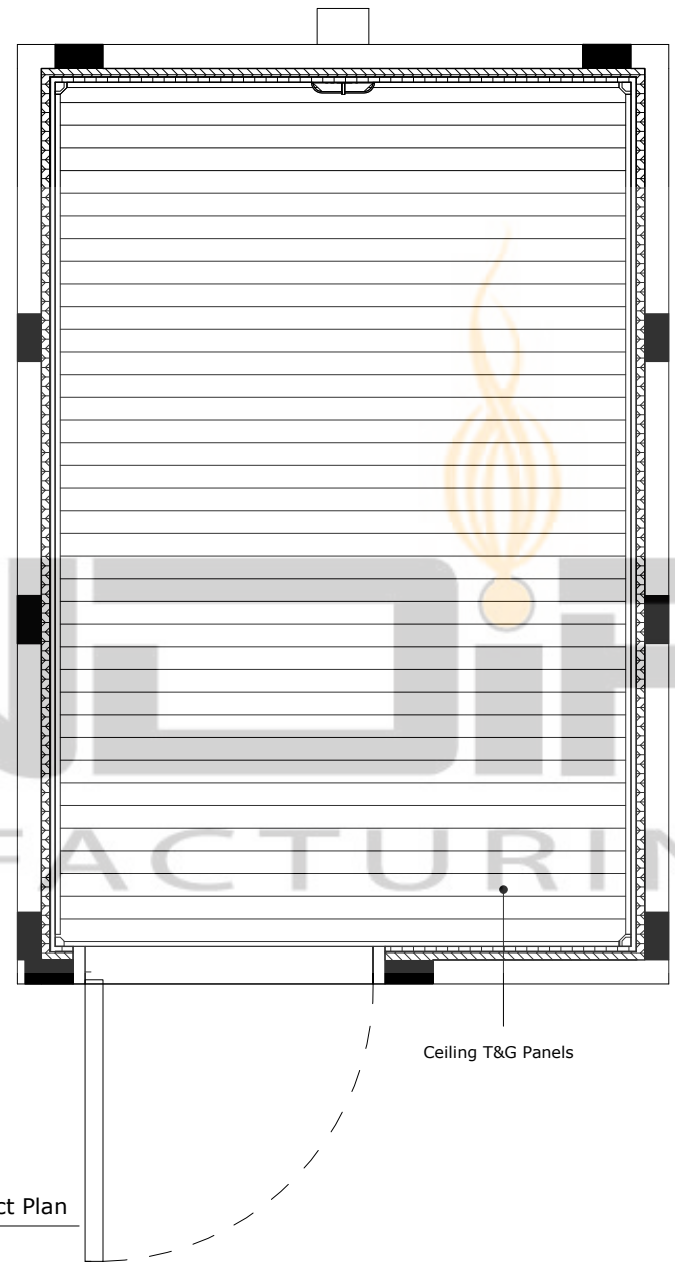

2 Ceiling Reflect Plan
3/4" = 1'-0"

Precut Sauna 48" x 72" x 84"
Top View and Ceiling Reflect Plan
Scandia Manufacturing

SCALE: 3/4" = 1'-0"

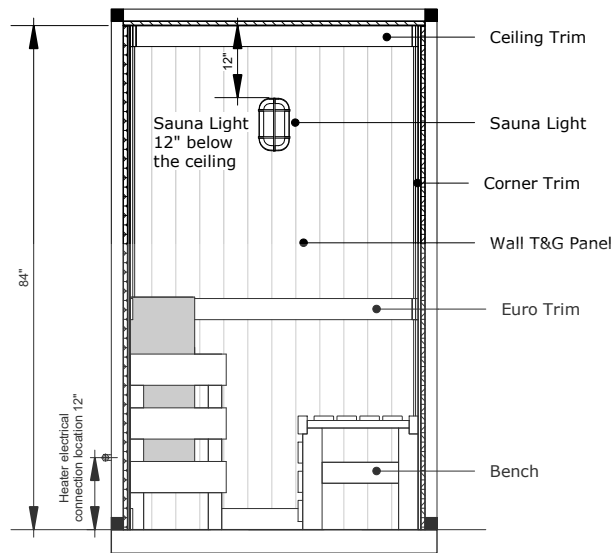

A Inside Elevation View 1
3/8" = 1'-0"

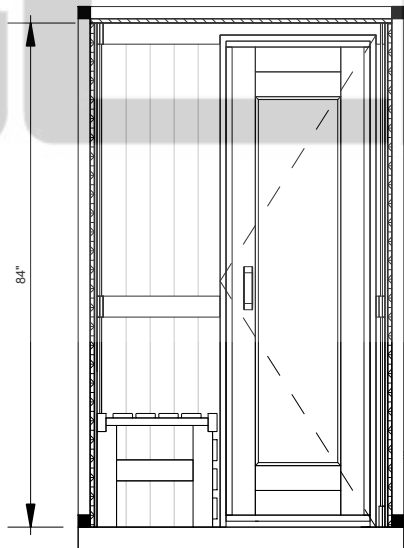

C Inside Elevation View 3
3/8" = 1'-0"

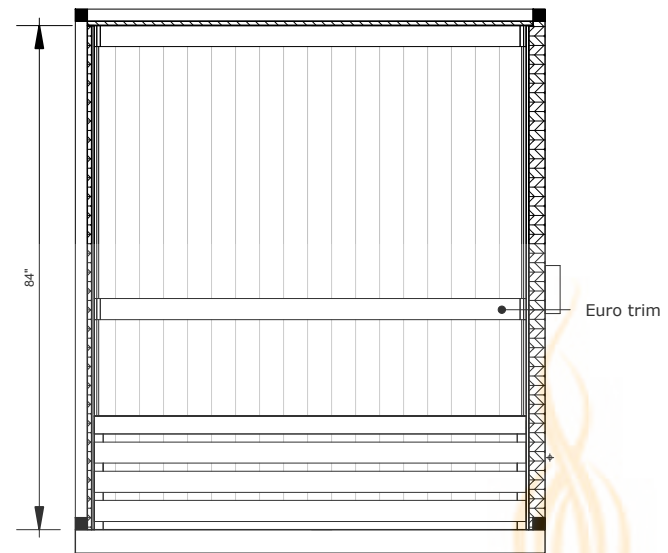

B Inside Elevation View 2
3/8" = 1'-0"

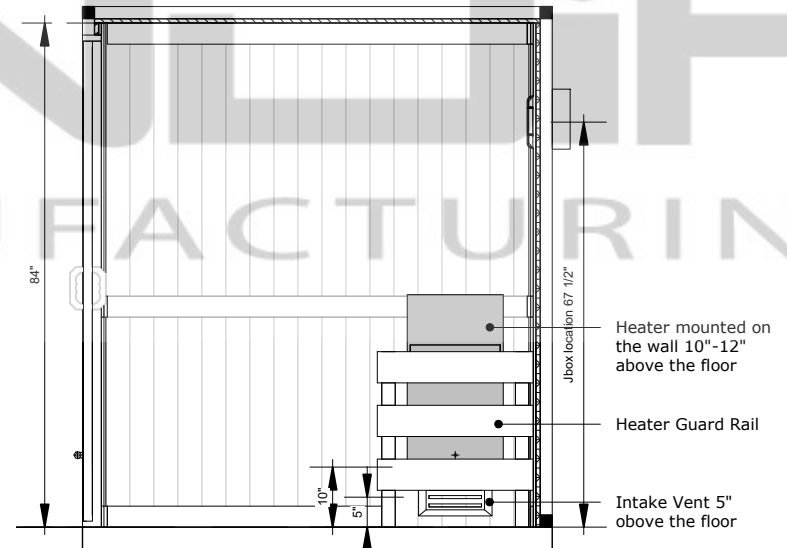

D Inside Elevation View 4
3/8" = 1'-0"

Precut Sauna 48" x 72" x 84"
Elevation Views
Scandia Manufacturing

SCALE: 3/8" = 1'-0"



(877) 467 2862
 www.scandiamfg.com
 customerservice@scandiamfg.com
 372 S Eagle Rd #341 Eagle, Idaho 83616

Scandia Manufacturing

Room Dimensions	48" W x 72" L x 84" H
Heater Size	4.5 KW Heater
Heater Guard Rail	26" W x 16" L x 29-1/4" H
Lighting	Standard Fixture
SAUNA FINISH	Vertical Grade A Clear Cedar Euro Trim
Flooring (w. Transition) (No flooring under the benches & the heater)	TruTile Flooring
Sauna Door	Small Cedar Door LEFT HINGE Provide RO 26" x 82"
Accessories/Customizations	

Customer Signature _____ Date _____

For Internal Use:

Name	QTY/Dimensions				Production Initials	Installer Initials
T&G Well Boards	35 and 60"	Above Door				
T&G Ceiling Boards						
Door	Door Type Small	Door Swing LH	Logos? YES	Door Trims		



(877) 467 2862
 www.scandiamfg.com
 customerservice@scandiamfg.com
 372 S Eagle Rd #341 Eagle, Idaho 83616

Benches & Legs	UB	UL	LB	LL		
Base Trim						
Split Trims	Split Ceiling Trim		Split Wall Trim			
Corner/Ceiling Trims	Corner Trims		Ceiling Trims			
Skirtings			End Caps			
Guard Rail						
Flooring (W. Transition)			No. of Pieces			
Salt Panels	No. of Panels		Dimensions			
Salt Wall Trim & LED Light	Trim Dimension		LED Length (ft)			
Accessories	Light, Medallions, Bucket & Ladle, Hygrometer Door Handle, Screws, HG Support, 1 Box of (2" Brand Nails, 1 1/4" Brad Nails)					
Other Accessories	Vapor Barrier		Wall Bracket			
Specialities/Extras: 4 Pieces of Trim at 84" Transition or Threshold						

Sauna Room - Corner trim detail

- Ceiling Trim
- Corner Medalion
- Corner Trim

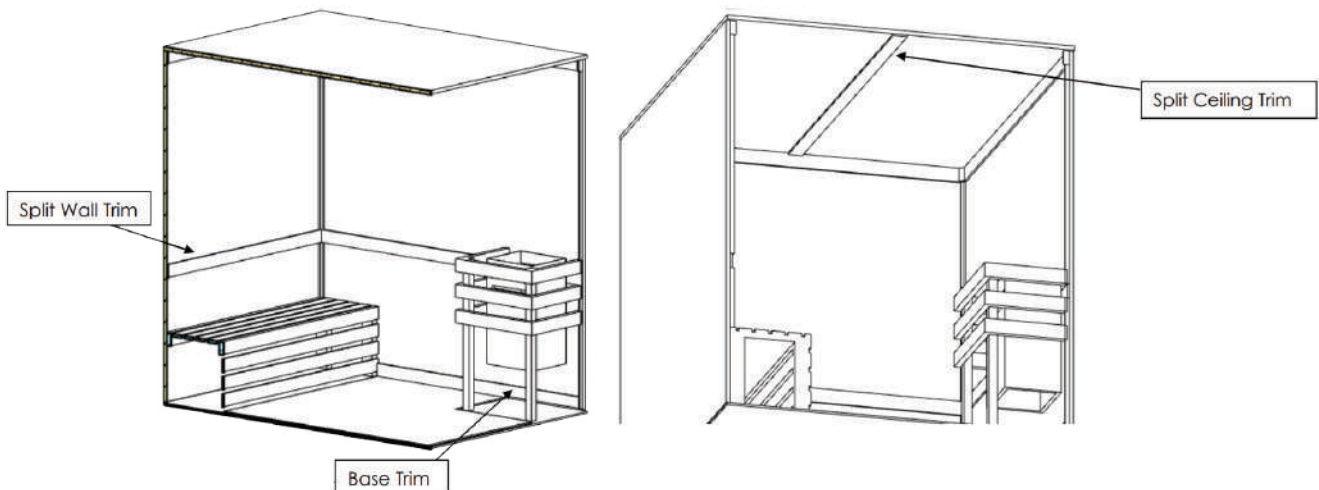
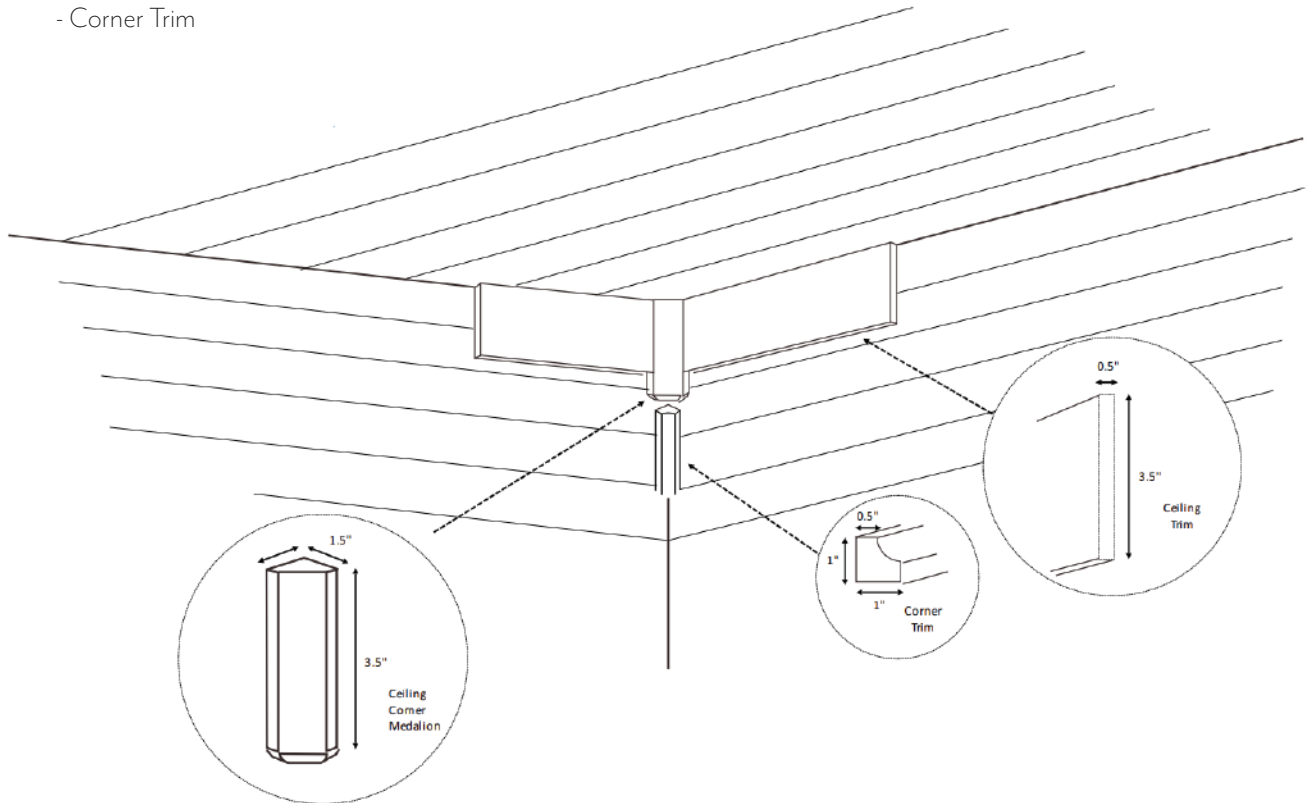

Sauna Room - Door Jamb Detail

- Door Jamb
- Door Hinge
- Fasteners

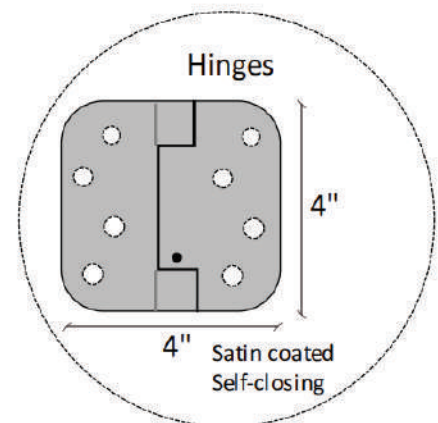
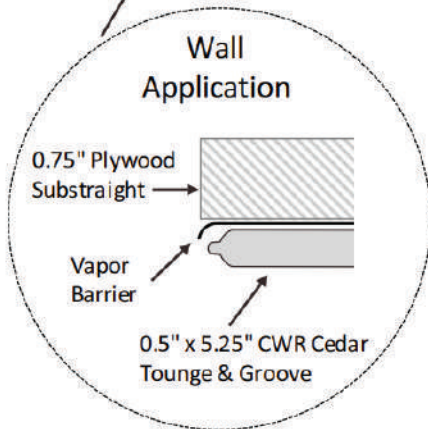
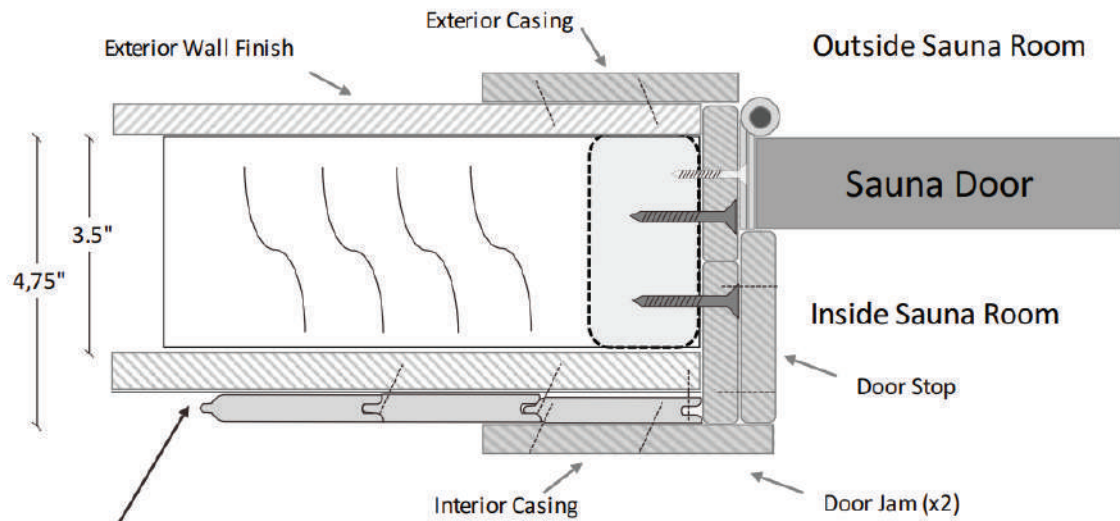

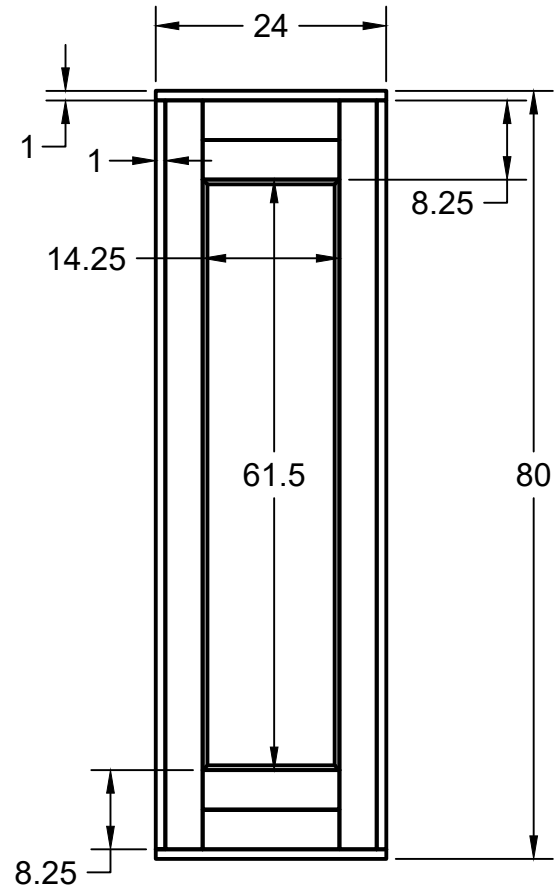
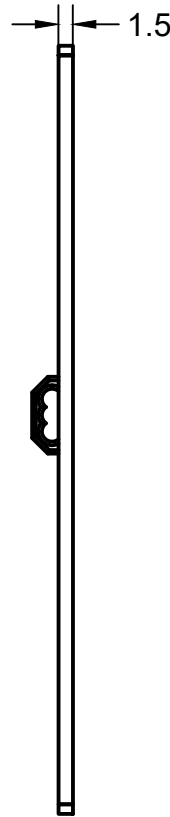
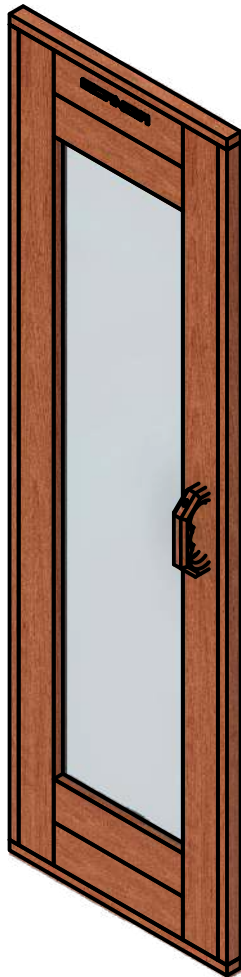

Glass Window Trim is $\frac{3}{8}$ " x $\frac{3}{4}$ "
 Face Window Trim is $\frac{1}{2}$ " x 1"

Units: Inches Fractional and Decimal Tolerances : - $\frac{1}{16}$ "	24 x 80 Sauna Door		
	6/22/2020	Scandia Manufacturing	REV
	1:15	DRAWN by William Buchanan	SHEET 1/1

Specifications



Dimensions

Product Depth (in.)	4.5
Product Height (in.)	8.5 in

Product Length (in.)	4.5 in
Product Width (in.)	5 in

Details

Bulb Type Included	No Bulbs Included
Exterior Lighting Accessory Type	Wall Mount Light
Exterior Lighting Product Type	Bulkhead Lights
Fixture Color/Finish	Black
Glass/Lens Type	Frosted
Included	Hardware Included
Light Bulb Base Code	Medium
Maximum Bulb Wattage	60 W Appliance
Maximum Wattage (watts)	60

Number of Bulbs Required	1
Outdoor Lighting Features	Rust Resistant,Water Resistant,Waterproof, Weather Resistant
Power Type	Hardwired
Product Weight (lb.)	1.69 lb
Recommended Light Bulb Shape Code	A19
Size	Small
UL Listing	1-UL Listed

Flush-Mount Fixture Wiring Instructions

NOTE: ALWAYS TURN POWER OFF BEFORE INSTALLING LIGHTING FIXTURES!
 IMPORTANT: YOU SHOULD USE A QUALIFIED ELECTRICIAN TO INSTALL THIS FIXTURE.

Installation (see fig. A)

1. Disconnect power at main electrical panel before installation.
2. Thread the mounting screws into the same side of the mounting strap as the Green ground screw.
3. Guide fixture wires through hole in center of mounting strap.
4. Follow wiring instructions carefully (listed below).
5. Attach mounting strap to outlet box using box screws provided with outlet box.
6. Mount fixture by aligning mounting holes in base with mounting screws. Positioning the mounting screw heads through the large openings of the keyhole shape slots. Rotate the fixture to seat the mounting screws, tighten mounting screws securely.

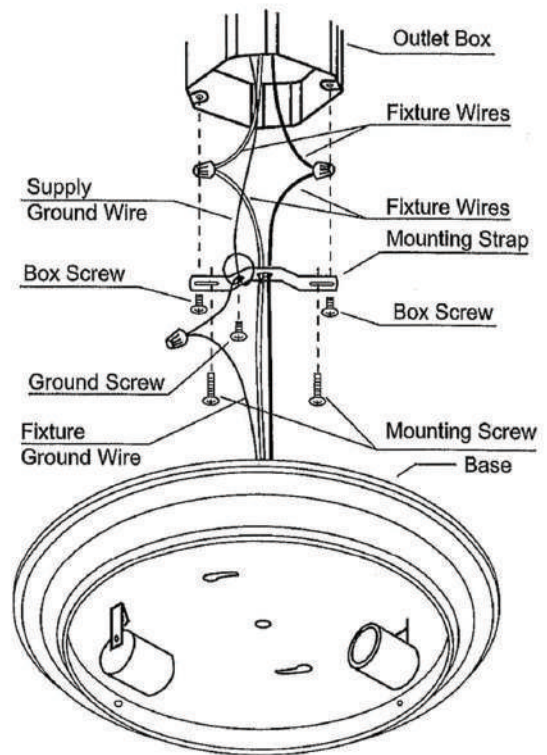
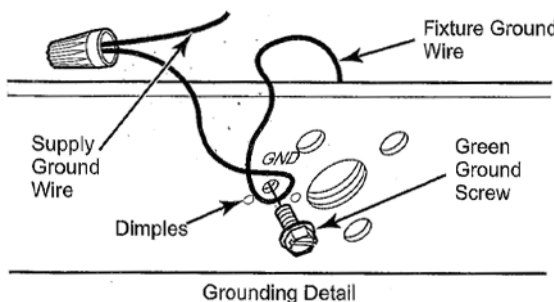

Fig. A

Wiring (see fig. B)

1. Split the conductors of the fixture wire about 4 inches, being careful not to expose any of the wire inside of the insulation.
2. Connect the fixture ground wire to the outlet box ground wire using wirenut (not provided). Connect outlet box ground wire to mounting strap with GREEN hex-head ground screw to tapped hole in mounting strap marked "GDN".
3. Connect the half of the fixture wire that is white, marked, or has a ribbed surface to the outlet box supply wire (WHITE). Connect the other half of the fixture wire that is black, unmarked, or has a smooth surface to the outlet box supply wire (BLACK or RED). Use wirenuts provided.
4. Spread the electrical splices so that the black wire are on one side of the outlet box and the white wire are on the other side.

Fig. B



Connect Black or Red House Wire to:	Connect White House Wire to:
Black	White
Parallel cord-SPT I & II (round & smooth)	Parallel cord-SPT I & II (square & ridged)
Clear, Brown, Gold or Black (without tracer)	Clear, Brown, Gold or Black (with tracer)
Insulated Wire (Other than GREEN) with copper conductor	Insulated Wire (Other than GREEN) with silver conductor

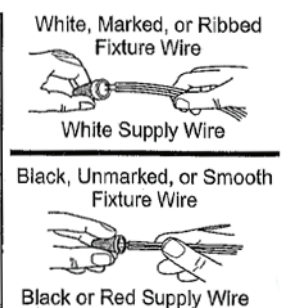

Flush-Mount Fixture Assembly Instructions II

- Step 1. Carefully unpack fixture and all components.
You should receive:
Fixture assembly, pipe nipple, cap nut, glass shade, wire cage, and mounting hardware.
- Step 2. Follow enclosed Flush-Mount Installation and Wiring Instructions.
- Step 3. Position fixture assembly over pipe nipple.
Firmly thread cap nut onto the pipe nipple, securing fixture assembly. See Figure 1.
- Step 4. Install lamp. (not included) into Lamp socket on the fixture assembly. See Figure 2.
- Step 5. Position the glass shade and wire cage below the fixture assembly, secure wire cage with mounting screws. See Figure 3.

NOTE: When installing lamps.
DO NOT EXCEED MAXIMUM WATTAGE RATING.

Fig. 1

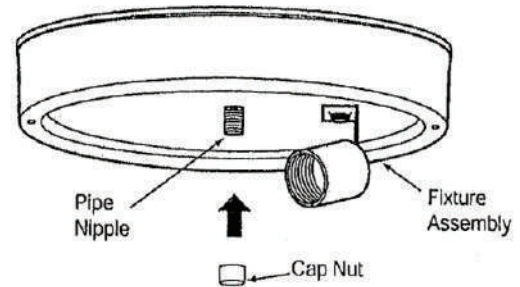

Fig. 2

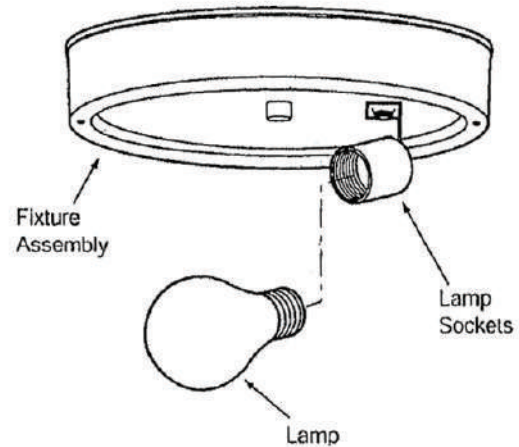
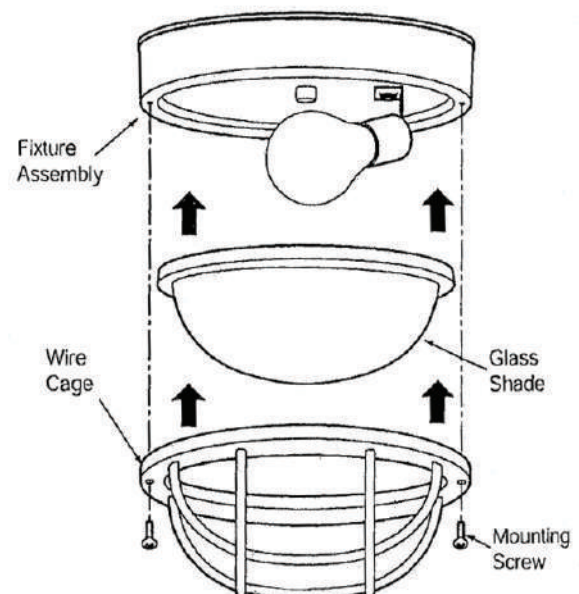

Fig. 3



Radiant Barrier Insulation

FSK Shield™ is an economy grade single-sided foil facing that is comprised of 0.0003" aluminum foil bonded to 30 lb. natural kraft paper with a flame retardant adhesive and is reinforced with tri-directional fiberglass scrim. FSK Shield™ is intended for use as an attic, roof, or wall radiant barrier and as a class A insulation facing. The product also can be used as an effective vapor barrier. FSK Shield™ is available in 1000 square foot rolls 54" wide. Other widths available by special order.

Radiant Barrier System (RBS) is a building construction consisting of a low emittance (normally 0.1 or less) surface (usually aluminum foil) bound-ed by an open air space. RBS is used for the sole purpose of limiting heat trans-fer by radiation and is not speci cally intended to reduce heat transfer by con-vection or conduction.

How Do Radiant Barriers Block Heat Transfer & What are the Bene ts? In a home without a radiant barrier at the roof line, your roof radiates solar-generated heat which elevates attic temperatures upward to 150 degrees or higher. These higher temperatures will increase the heat gain in your air con-ditioning ducts and reduce the performance of mass insulation (the R-values of mass insulation are determined at 75oF - higher temperatures lowers the R-value). In addition, the extreme temperatures will saturate the building mate-rials in the attic. This stored heat acts as a heat sink and will continue to trans-fer heat into the living area of your home even after the sun has set, making your air conditioner run longer and consume more electricity. A radiant barri-er stops 97% of radiant heat transfer which improves the perfor-mance of the insulating material and lowers attic temperatures as much as 30oF. Another bene t is that a cooler attic will transfer less heat into air conditioner ducts. Radiant barriers also expand the use of space in your home like garages, work-rooms, porches, etc. Radiant barriers also reduce winter heat loss.

R-Value is the rating given to show the resistance "R" to heat ow and is used to compare insulation materials that trap air or a gas or reduce heat ow by convection and conduction. Therefore, R-values are not a true measure of the thermal performance of Radiant Barrier Systems.

Thermal Performance – FSK Shield™ has thermal applications other than as a Radiant Barrier. However, in all cases, FSK Shield™ should be installed so the foil is exposed to an airspace or thermal performance will be compromised. R-values in closed cell con gurations such as wall, ceiling, and oor cavities can be calculated using the ASHRAE book of fundamentals.

Effective Air Space Emittance is the radiation heat transfer property "E" of an air space determined by the emis-sivity of the surfaces bounding that air space.

Emissivity is the ratio of the total radi-ant ux emitted by a body to that emit-ted by an ideal black body at the same temperature.

Vapor Barrier Application – FSK Shield™ can be used as an effective vapor barrier and can be installed with foil or paper exposed. All seams should be taped with Fi-Foil's foil tape.

Class A Flame Spread Facing – FSK Shield™ can be used to improve ame spread and smoke developed ratings of wall systems, speci cally unfaced ber-glass batts and can be installed with foil or paper exposed. Installing FSK Shield with the foil side exposed will provide better ame spread rating. Tape seams with Fi-Foil's foil tape.

Table of Emittances E-Values (the lower the better)	
Aluminum Foil	03-.05
Common building materials, including wood, masonry, and standard mass insulation.	82-.90

Product Information	
Width of Roll	54"
Diameter	5"
Lineal Footage	222'
Coverage	1000 sq. ft.
Weight	25 lbs.

Test Data	
ASTM E-96 Water Vapor	
Permeance	0.02
ASTM E-84/UL 723 Surface Burning	
Kraft Exposed	
Flame Spread Rating.	25
Kraft Exposed	
Smoke Developed Rating	10
Foil Exposed	
Flame Spread Rating	5
Foil Exposed	
Smoke Developed Rating	0
FSKShield & Unfaced Batt	
Flame Spread Rating.	15
Smoke Developed Rating	0
ASTM E-408	
Emissivity	0.03
ASTM D-828	
Tensile Strength	
lbs./in	MD:40; XD:25
Scrim pattern	
per lineal inch	MD:2; XD:3
ASTM D-774	
Mullen Burst Strength	40 psi
ASTM C-1136	
Mold and Mildew	Pass
Dimensional Stability	
percent length change	0.25%
Low Temperature Resistance	
no cracking or delam	-40°F
High Temperature Resistance	
no cracking or delam	240°F
Puncture Resistance, Beach	
puncture units (Joules)	25



Keep Your Saunas Clean!

Clean the sauna often to keep the fresh and well-maintained appearance.
Let your patrons feel good about their experience in your sauna.

DAILY: Enter the sauna each morning or evening, as appropriate, to conduct a Cleaning Inspection and perform the cleaning activities.

DAILY: Enter and clean the sauna when it has cooled down.

DAILY: Use a bucket of warm water with a mild detergent soap (a liquid soap is sufficient) and clean sponge or rag to wipe the bench surfaces and floor.

Do not use petroleum-based detergents. They can discolor your wood and will leave a residue which could emit irritating fumes.

DAILY: Wet mop the tile or cement floor with the same mild soap mixture.

If something unpleasant other than ladled water is applied to the heater's rocks, clean them after they have completely cooled. Soak them in a soapy (light detergent) mixture of warm water. Wash off with a sponge, then rinse in clean water. Allow the rocks to dry, then re-apply rocks to the heater trough. Clean the heater and trough of the foreign substance. Gradually build heat in the sauna to totally dry the rocks. If replacement rocks are needed, call Scandia Manufacturing.

Never ever turn a hose on the sauna to wash it down.

WEEKLY: Remove and inspect all stones and clean the trough. If a stone is broken throw it away. If broken stones are allowed to remain in the trough they will break down into a sandy grit. That grit will eat a hole in the stainless steel. This damage is not covered by the warranty. The stainless steel shell can be cleaned with regular stainless steel cleaner.

NOTE: From time to time, benches and walls can be lightly sanded to remove any stains or rough spots on benches, wall, and cedar flooring. After sanding, apply sauna wood oil (available through Scandia) to give the wood a new look.