

MAMBA STACK

FC :MAMBA APP F405 MK I
ESC:MAMBA F50 PRO



Stack Specifications:

MCU	STM32F405RGT6
Frequency	168MHz
GYRO	MPU6000
OSD	AT7456E
Blackbox	16M Memory
Uarts	6 Set
Receiver	TBS/SBUS/IBUS/DSM
I2C	Yes
RSSI Pad	Yes
F.Port	Yes
Buzzer Pad	Yes
CURR Pad	Yes
ESC Signal	4 Set
BEC 3.3V	0.5A
BEC 5V	3A
BEC 9V (DJI Power)	3A
MB LED	Yes
BF LED	Yes
WIFI	Yes
Input	6S Lipo
TVS Protection	Yes
Soft Ware	Betaflight
Mounting	30.5×30.5mm/M3
Size	38.0×41.5×7.5mm
Weight	9.5g

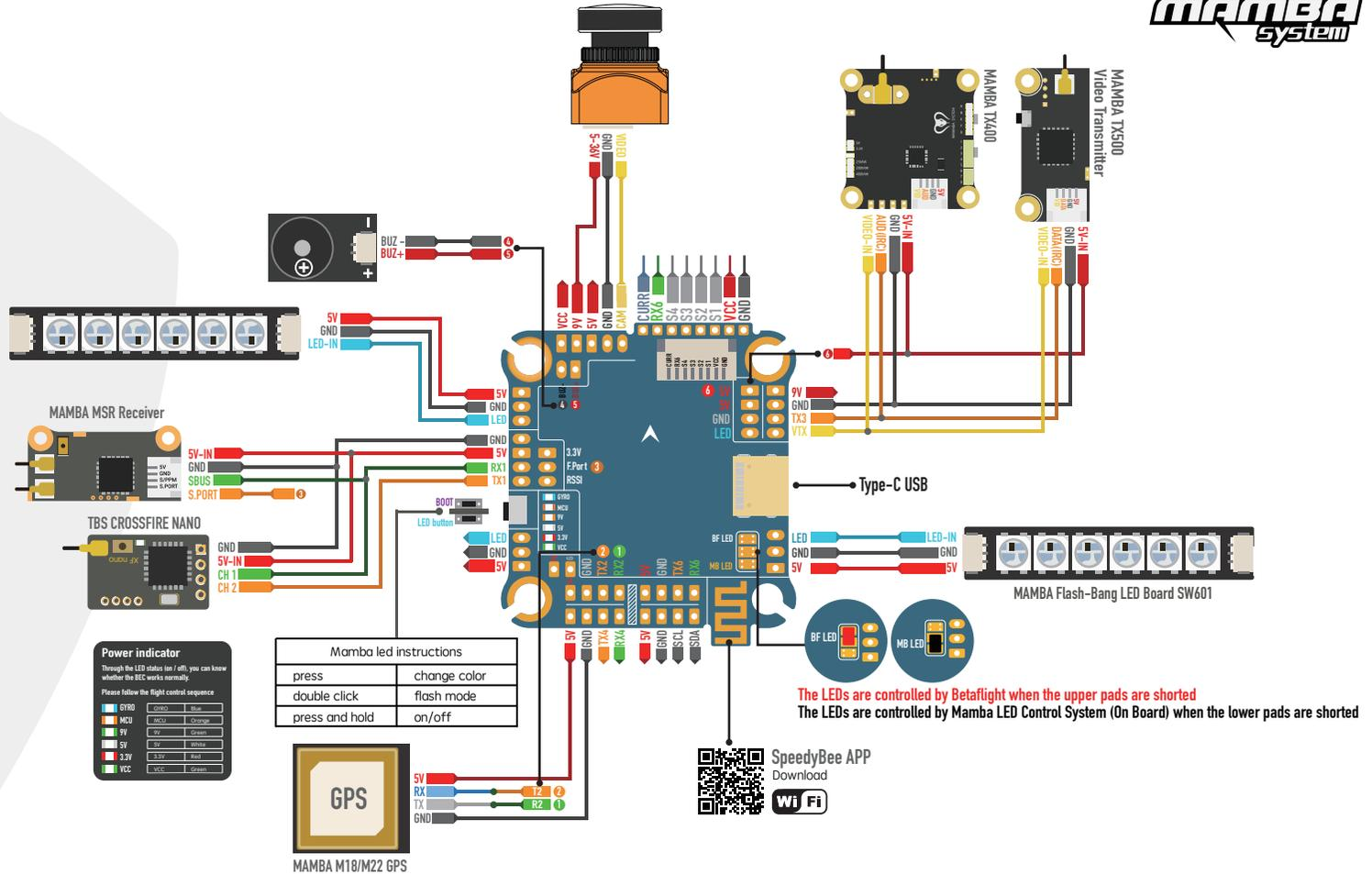

Web: www.diatone.us

Target: MAMBAF405US_I2C

Main firmware STM32 F405

Config file MAMBAF405US_I2C

When Using Compass Magnetometer,

Following Command:

set mag_i2c_device = 1

set mag_bustype = i2c

The Default Port:

UART 1 Receiver

UART 2 Vacancy

UART 3 VTX

UART 4 WIFI

UART 5 S/F.Port

UART 6 TELE

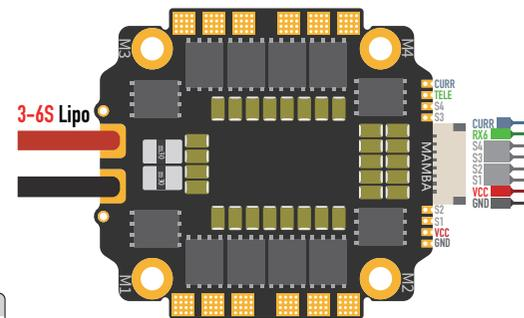
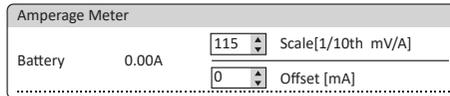
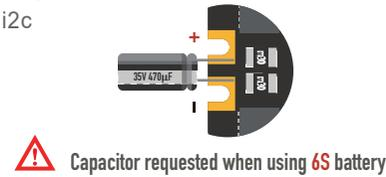

MAMBA F50 PRO ESC

ESC

CURR	Yes
Telemetry	Yes
Output Current	50A
Peak Current	55A
Input	3-6S Lipo
BLheli-32	Yes
Target	MAMBA F50 PRO
Protocol	Dshot 300/600/1200
Mounting	30.5×30.5mm, Ø 3
Size	45.0×41.0×6.5mm
Weight	15g

MAMBA STACK

FC :MAMBA APP F405 MK I
ESC:MAMBA F50



Stack Specifications:

MCU	STM32F405RGT6
Frequency	168MHz
GYRO	MPU6000
OSD	AT7456E
Blackbox	16M Memory
Uarts	6 Set
Receiver	TBS/SBUS/IBUS/DSM
I2C	Yes
RSSI Pad	Yes
F.Port	Yes
Buzzer Pad	Yes
CURR Pad	Yes
ESC Signal	4 Set
BEC 3.3V	0.5A
BEC 5V	3A
BEC 9V (DJI Power)	3A
MB LED	Yes
BF LED	Yes
WIFI	Yes
Input	6S Lipo
TVS Protection	Yes
Soft Ware	Betaflight
Mounting	30.5×30.5mm/M3
Size	38.0×41.5×7.5mm
Weight	9.5g

Web: www.diatone.us

Target: MAMBAF405US_I2C

Main firmware STM32 F405

Config file MAMBAF405US_I2C

When Using Compass Magnetometer;

Following Command:

set mag_i2c_device = 1

set mag_bustype = i2c

The Default Port:

- UART 1 Receiver
- UART 2 Vacancy
- UART 3 VTX
- UART 4 WIFI
- UART 5 S/F.Port
- UART 6 TELE

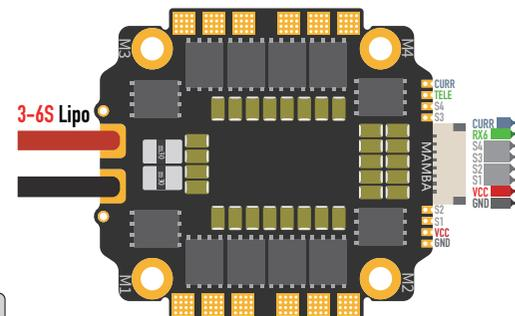
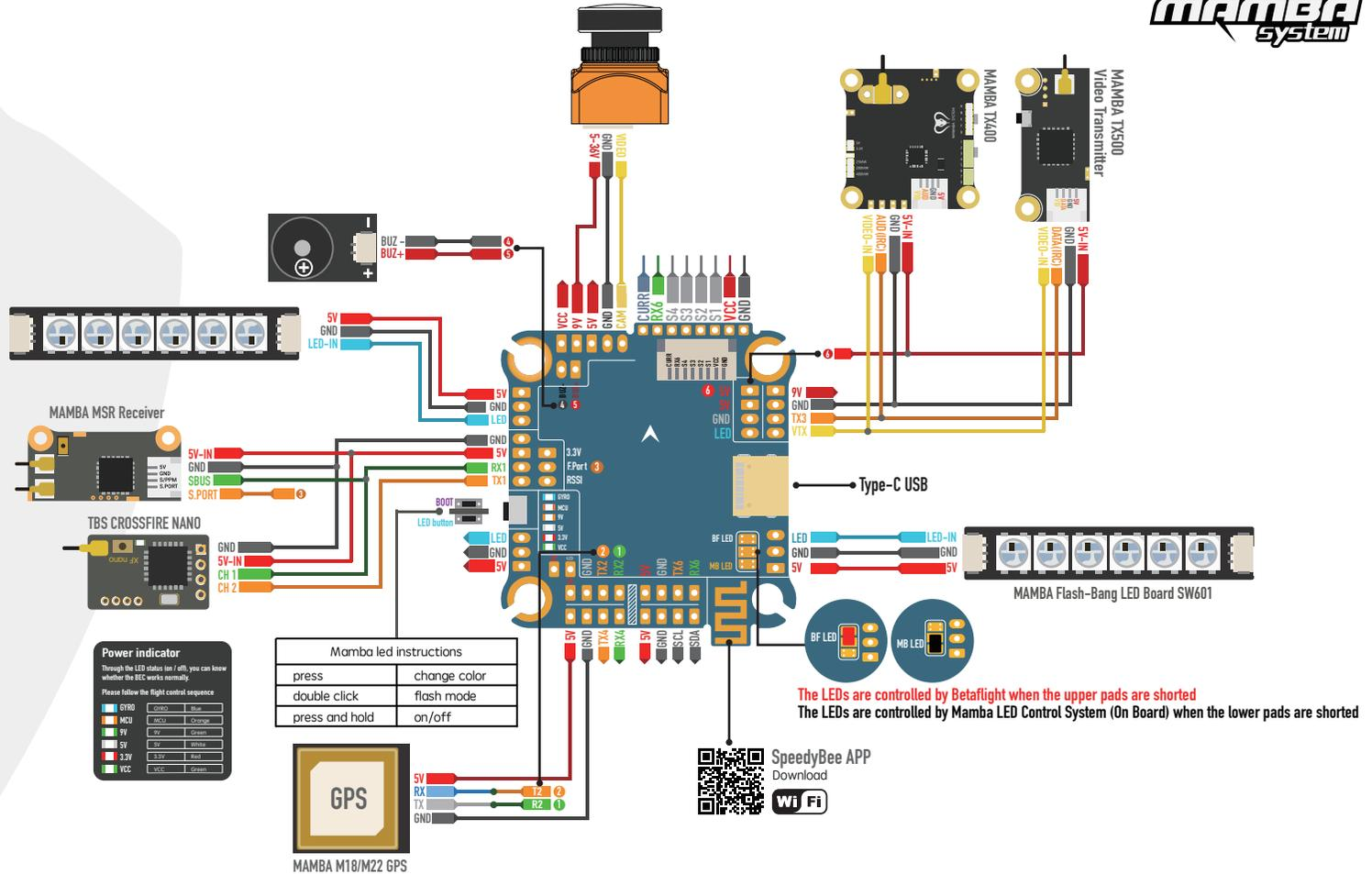

MAMBA F50 ESC

ESC

CURR	Yes
Output Current	50A
Peak Current	55A
Input	3-6S Lipo
BLheli-32	Yes
Target	CH40
Protocol	Dshot 300/600
Mounting	30.5×30.5mm,∅ 3
Size	45.0×41.0×6.5mm
Weight	15g