



**FITTING INSTRUCTIONS FOR CP0416BL**  
**AERO CRASH PROTECTORS KAWASAKI Z650 2017**



Picture A



Picture B

**THIS KIT CONTAINS THE ITEMS PICTURED AND LABELLED BELOW.**  
**DO NOT PROCEED UNTIL YOU ARE SURE ALL PARTS ARE PRESENT.**

**Please note that the way the kit is packed does not necessarily represent the way of mounting to the bike.**

THE PARTS SHOWN MAY BE REPRESENTATIVE ONLY (FOR CLARITY OF INSTRUCTIONS ONLY).

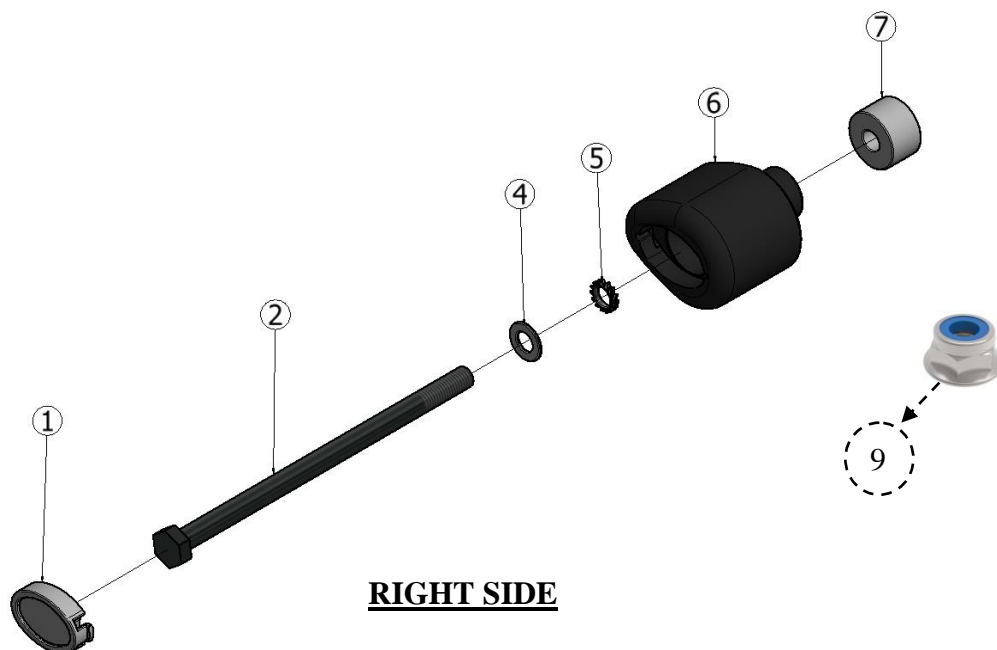

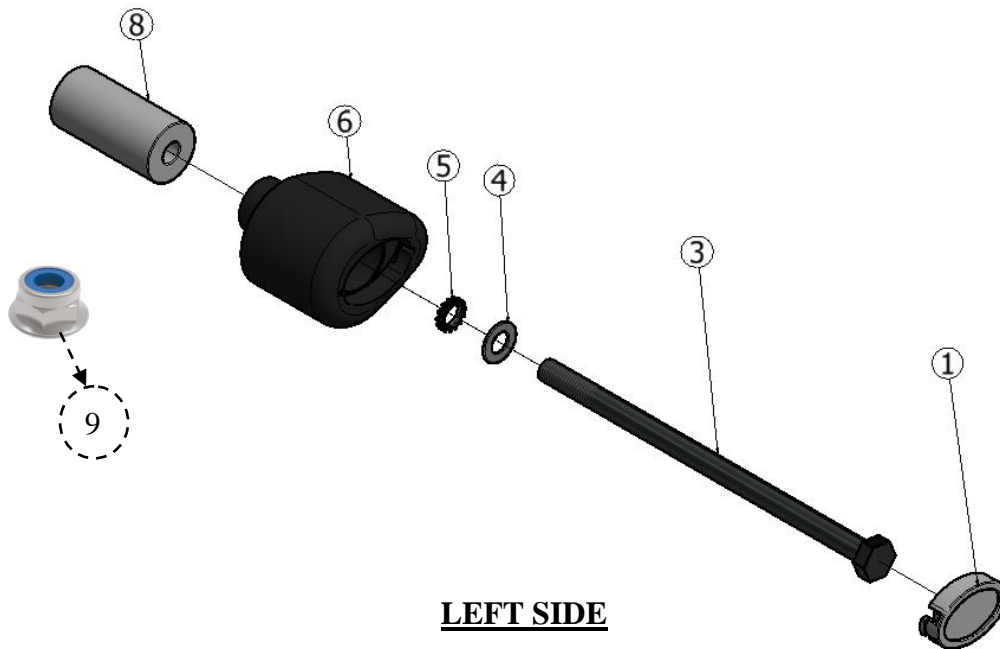

### LEFT SIDE

### LEGEND

- ITEM 1 = CRASH PROTECTOR CAPS (BC0002) (x2).  
 ITEM 2 = M10 x 1.5 x 180mm LONG HEX HEAD BOLT (x1).  
 ITEM 3 = M10 x 1.5 x 190mm LONG HEX HEAD BOLT (x1)  
 ITEM 4 = M10 WASHERS (x2)  
 ITEM 5 = LOCK-WASHERS (LW0001) (x2).  
 ITEM 6 = CRASH PROTECTOR (B0431 with CS341 & S0255) (x2).  
 ITEM 7 = SPACER (S1002 – 17.5mm LONG) (x1).  
 ITEM 8 = SPACER (S1001 – 58mm LONG) (x1)  
 ITEM 9 = M10 NYLOC NUTS (x2)

Please note that in cases where kits are packed with rubber washers holding the components onto the bolt – *the rubber washers should be thrown away!*

### TOOLS REQUIRED

- A Wrench
- Socket set to include 14mm & 17mm sockets.
- Torque wrench (up to 40N/m).

TOWARDS REAR  
OF BIKE

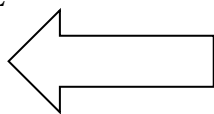

TOWARDS FRONT  
OF BIKE

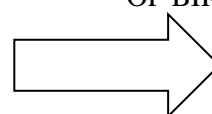

PICTURE C



### **GENERAL TORQUE SETTINGS**

M4 BOLT = 8Nm  
 M5 BOLT = 12Nm  
 M6 BOLT = 15Nm  
 M8 BOLT = 20Nm  
 M10 BOLT = 40Nm

### **FITTING INSTRUCTIONS**

- Starting from the right hand side (as you sit on bike), remove the front engine bolt using a wrench and 14mm socket. Remove the nut once the bolt is fully undone.
- From the kit, take the M10 x 180mm Long bolt (Item 2) and slide in one M10 washer (Item 4) and one lock washer (Item 5). Insert the assembly through one of the bobbins (Item 6).
- Insert the 17.5mm long spacer (Item 7) to the assembly with the flat side sitting against the bobbin. Check the assembly matches the exploded diagram on page 1.
- Offer the whole assembly towards the frame and secure using an M10 nyloc nut (Item 9) provided in the kit. Tighten the crash protector bolt until you feel some compression from inside the protector using a 17mm socket and wrench. **PLEASE NOTE THE CRASH PROTECTOR MUST BE POSITIONED AS IN PICTURE 'C' WITH BIGGER END TOWARD FRONT OF BIKE.** Turn a little more so that you feel the compression increase slightly. Then apply a quarter turn. Do not over tighten as damage can occur to the bike. Do not exceed 40N/m of torque.
- On the left hand side, remove the front engine bolt using a wrench and 14mm socket. Remove the nut once the bolt is fully undone.
- From the kit, take the M10 x 190mm Long bolt (Item 3) and slide in one M10 washer (Item 4) and one lock washer (Item 5). Insert the assembly through the remaining bobbin (Item 6).
- Insert the 58mm long spacer (Item 8) to the assembly. Check the assembly matches the exploded diagram on page 1.
- Offer the whole assembly towards the frame and secure using an M10 nyloc nut (Item 9) provided in the kit. Tighten the crash protector bolt until you feel some compression from inside the protector using a 17mm socket and wrench. **PLEASE NOTE THE CRASH PROTECTOR MUST BE POSITIONED AS IN PICTURE 'C' WITH BIGGER END TOWARD FRONT OF BIKE.** Turn a little more so that you feel the compression increase slightly. Then apply a quarter turn. Do not over tighten as damage can occur to the bike. Do not exceed 40N/m of torque.
- If not already fitted fit bubble stickers into recess of both crash protector caps.
- Fit crash protector caps into both crash protectors.

ISSUE 1 06/02/2017 (HH)

**Digital copies of these instructions are available to download from [www.rg-racing.com](http://www.rg-racing.com)**

#### **CONSUMER NOTICE**

The catalogue description and any exhibition of samples are only broad indications of the Products and R&G may make design changes which do not diminish their performance or visual appeal and supplying them in such state shall conform to the order. The Buyer acknowledges no representation or warranty (other than as to title) has been given or will apply to the Products other than those in R&G's order or confirmation and the Buyer confirms it has chosen the Products as being of merchantable quality and suitable for its particular purposes. Where R&G fits the Products or undertakes other services it shall exercise reasonable skill and care and rectify any fault free of charge unless the workmanship has been disturbed. The Buyer is responsible for ensuring that the warranty on the motorcycle is not affected by the fitting of the Products. On return of any defective Products R&G shall at its option either supply a replacement or refund the purchase money but shall not be liable if the Products have

R&G Racing

Unit 1, Shelley's Lane, East Worldham, Alton, Hampshire, GU34 3AQ

Tel: +44 (0)1420 89007 Fax: +44 (0)1420 87301 [www.rg-racing.com](http://www.rg-racing.com) Email: [info@rg-racing.com](mailto:info@rg-racing.com)



been modified or used or maintained otherwise than in accordance with R&G's or manufacturer's instructions and good engineering practice or if the defect arises from accident or neglect. Other than identified above and subject to R&G not limiting its liability for causing death and personal injury, it shall not be liable for indirect or consequential loss and otherwise its liability shall be limited to the amounts paid by the Buyer for the Products or the fitting or service concerned. These terms do not affect the Buyer's statutory rights.

**R&G RACING RETURNS POLICY (NON-FAULTY GOODS)**

Returns must be pre-authorized (if not pre-authorized the return will be rejected). Goods may only be returned direct to us if they were purchased direct from us (customer must prove if necessary). Otherwise to be returned to original vendor. Goods must be in re-sellable condition, in the opinion of R&G Racing. All returns are subject to a 25% restocking and handling fee (25% of the gross value exc. P&P – at the prevailing price at time of purchase). The customer must pay any and all carriage charges. No returns of discontinued products, unless within 14 days of purchase. This policy does not affect your statutory rights and does not refer to faulty goods.



**NOTICE DE MONTAGE POUR CP0416BL**  
**PROTECTIONS CRASH LATERALES**  
**KAWASAKI Z650 2017**



Photo A

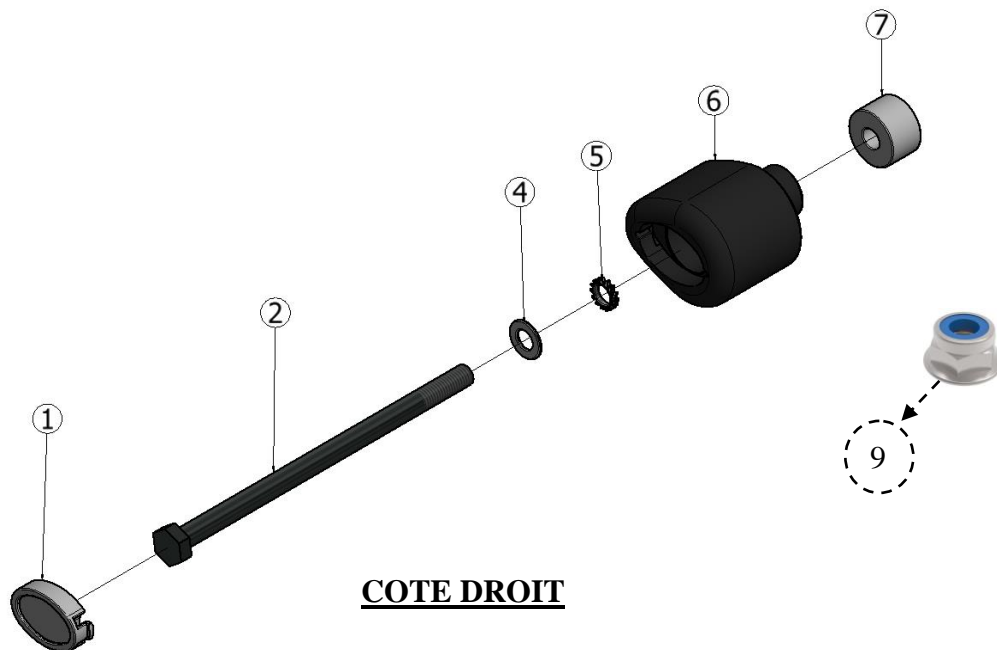

Photo B

**LE KIT CONTIENT LES ARTICLES EXPOSES CI-DESSOUS, VERIFIER QUE TOUTES LES PIECES SOIENT PRESENTES AVANT DE PROCEDER AU MONTAGE.**

La façon dont le kit est emballé ne correspond pas forcément à la façon de monter les pièces sur la moto.

Les pièces présentées peuvent n'être que représentatives, afin de faciliter et clarifier les instructions de montage).



**COTE DROIT**

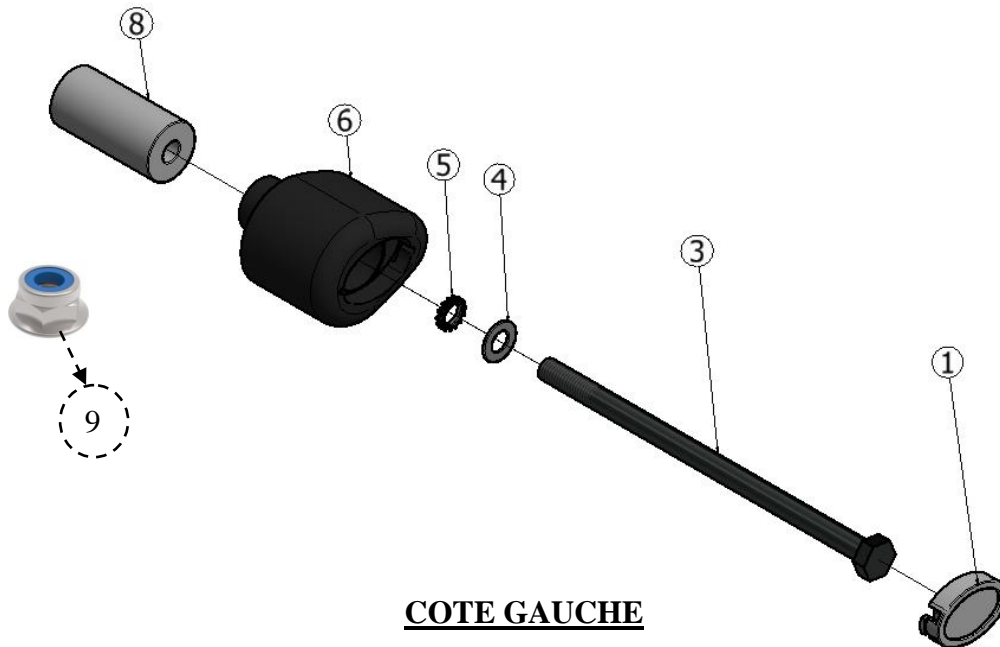

### COTE GAUCHE

### LEGENDE

- ARTICLE 1 = CAPUCHONS DE PROTECTION (BC0002) (x2).  
 ARTICLE 2 = M10 x 1.5 x 180mm BOULON (x1).  
 ARTICLE 3 = M10 x 1.5 x 190mm BOULON (x1)  
 ARTICLE 4 = M10 RONDELLES (x2)  
 ARTICLE 5 = RONDELLES DE BLOCAGE (LW0001) (x2).  
 ARTICLE 6 = PROTECTION CRASH (B0431 avec CS341 & S0255) (x2).  
 ARTICLE 7 = ENTRETOISE (S1002 – 17.5mm DE LONG) (x1).  
 ARTICLE 8 = ENTRETOISE (S1001 – 58mm DE LONG) (x1)  
 ARTICLE 9 = M10 ECROUS (x2)

Notez que si les kits sont emballés avec des rondelles en caoutchouc servant à tenir les composants, *ces rondelles doivent être jetées.*

### OUTILS REQUIS

- Clés de 14mm & 17mm.
- Clé dynamométrique (à 40Nm).

ARRIERE MOTO

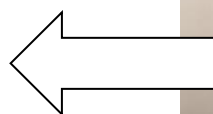

AVANT MOTO

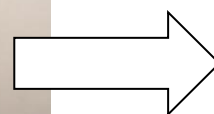



## PHOTO C

### COUPLES DE SERRAGE RECOMMANDES

M4 BOULON = 8Nm  
 M5 BOULON = 12Nm  
 M6 BOULON = 15Nm  
 M8 BOULON = 20Nm  
 M10 BOULON = 40Nm

### NOTICE DE MONTAGE

- En commençant du côté droit (lorsqu'on est assis sur la moto), enlever le boulon moteur avant à l'aide d'une clé à douille de 14mm. Enlever l'écrou une fois que le boulon est complètement enlevé.
- Dans le kit, prendre un boulon M10 x 180mm (Article 2) puis glisser une rondelle M10 (Article 4) et une rondelle de blocage (Article 5). Insérer l'ensemble dans l'une des bobines de protection (Article 6).
- Insérer une entretoise de 17.5mm (Article 7) sur l'assemblage avec la partie plate placée contre la bobine. Vérifier que l'assemblage correspond au schéma présent en page 1.
- Monter l'assemblage contre le cadre puis fixer à l'aide d'un écrou M10 (Article 9) fourni dans le kit. Serrer le boulon de protection crash avec une clé de 17 mm jusqu'à ce que vous sentiez une légère compression. **LA PROTECTION DOIT ETRE POSITIONNEE COMME EN "C" AVEC LE COTE ARRONDI LE PLUS GROS EN DIRECTION DE L'AVANT DE LA MOTO.** Tourner un peu plus afin d'accentuer légèrement la compression. Ne pas trop serrer, au risque d'abîmer la moto. Pas plus de 40 Nm de couple.
- Du côté gauche, enlever le boulon moteur avant à l'aide d'une clé à douille de 14mm. Enlever l'écrou une fois que le boulon est complètement enlevé.
- Dans le kit, prendre un boulon M10 x 190mm (Article 3) puis glisser une rondelle M10 (Article 4) et une rondelle de blocage (Article 5). Insérer l'ensemble dans l'une des bobines de protection (Article 6).
- Insérer une entretoise de 58mm (Article 8) sur l'assemblage. Vérifier que l'assemblage correspond au schéma présent en page 1
- Monter l'assemblage contre le cadre puis fixer à l'aide d'un écrou M10 (Article 9) fourni dans le kit. Serrer le boulon de protection crash avec une clé de 17 mm jusqu'à ce que vous sentiez une légère compression. **LA PROTECTION DOIT ETRE POSITIONNEE COMME EN "C" AVEC LE COTE ARRONDI LE PLUS GROS EN DIRECTION DE L'AVANT DE LA MOTO.** Tourner un peu plus afin d'accentuer légèrement la compression. Ne pas trop serrer, au risque d'abîmer la moto. Pas plus de 40 Nm de couple.
- Si cela n'est pas déjà fait, placer les stickers en caoutchouc dans le creux des 2 capuchons de protection crash.
- Placer les capuchons dans les 2 protections crash.

ISSUE 1 06/02/2017 (HH)

**Notice disponible au téléchargement sur [www.rg-racing.com](http://www.rg-racing.com)**



#### **CONSUMER NOTICE**

The catalogue description and any exhibition of samples are only broad indications of the Products and R&G may make design changes which do not diminish their performance or visual appeal and supplying them in such state shall conform to the order. The Buyer acknowledges no representation or warranty (other than as to title) has been given or will apply to the Products other than those in R&G's order or confirmation and the Buyer confirms it has chosen the Products as being of merchantable quality and suitable for its particular purposes. Where R&G fits the Products or undertakes other services it shall exercise reasonable skill and care and rectify any fault free of charge unless the workmanship has been disturbed. The Buyer is responsible for ensuring that the warranty on the motorcycle is not affected by the fitting of the Products. On return of any defective Products R&G shall at its option either supply a replacement or refund the purchase money but shall not be liable if the Products have been modified or used or maintained otherwise than in accordance with R&G's or manufacturer's instructions and good engineering practice or if the defect arises from accident or neglect. Other than identified above and subject to R&G not limiting its liability for causing death and personal injury, it shall not be liable for indirect or consequential loss and otherwise its liability shall be limited to the amounts paid by the Buyer for the Products or the fitting or service concerned. These terms do not affect the Buyer's statutory rights.

#### **R&G RACING RETURNS POLICY (NON-FAULTY GOODS)**

Returns must be pre-authorized (if not pre-authorized the return will be rejected). Goods may only be returned direct to us if they were purchased direct from us (customer must prove if necessary). Otherwise to be returned to original vendor. Goods must be in re-sellable condition, in the opinion of R&G Racing. All returns are subject to a 25% restocking and handling fee (25% of the gross value exc. P&P – at the prevailing price at time of purchase). The customer must pay any and all carriage charges. No returns of discontinued products, unless within 14 days of purchase. This policy does not affect your statutory rights and does not refer to faulty goods.