

**DUCATI DIAVEL 2016
OIL COOLER GUARD**

Product Reference - 13090

Kit Contents

- A** 1 x Oil Cooler Guard
- B** 16 x 5mm Star Lock Washers

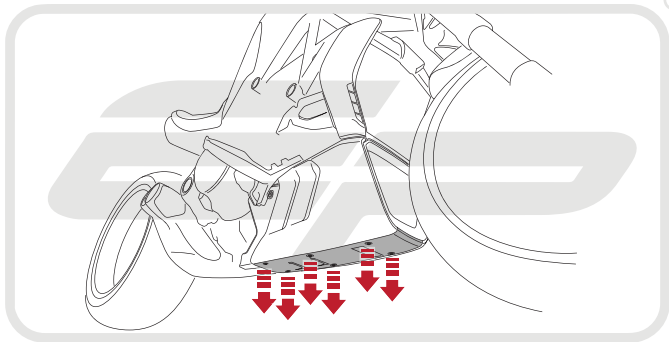

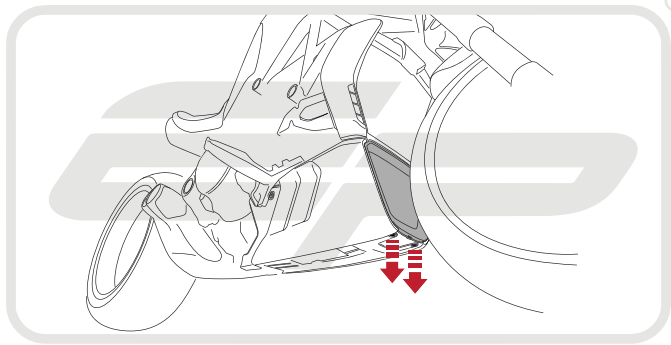

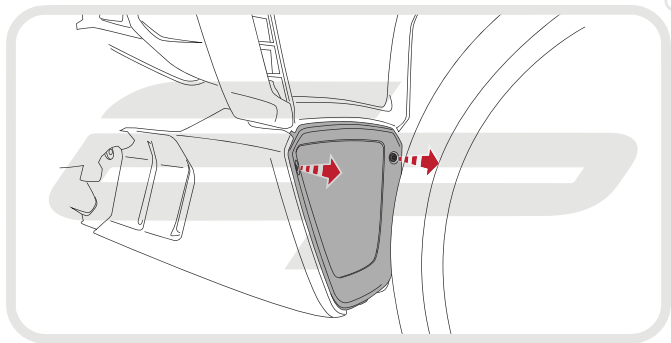

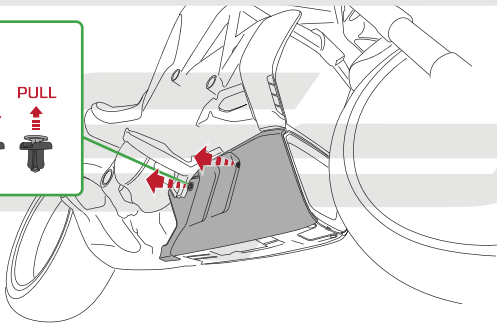
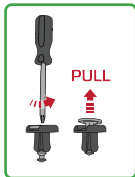

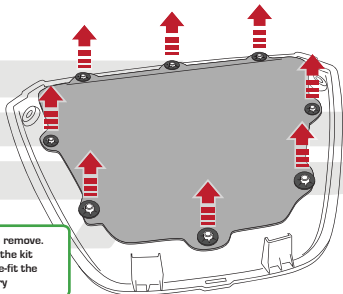

Star washers require cutting to remove.
There are enough washers in the kit
to fit the EP Guards and also re-fit the
standard grill if necessary

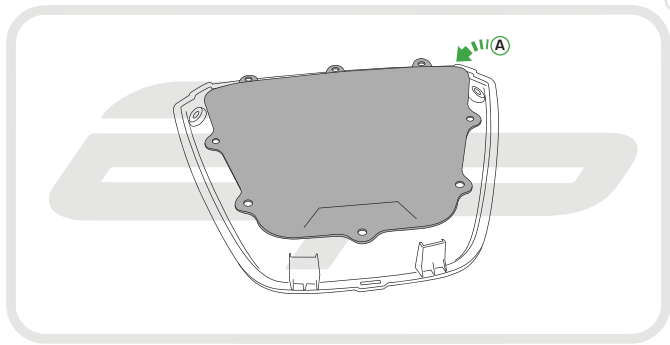

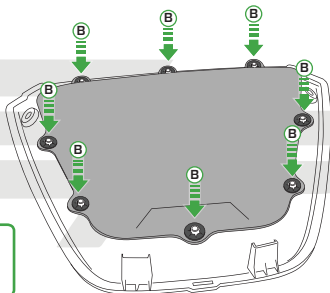

Push Star washers firmly over 5mm bosses ensuring a firm location is achieved



Reverse Stages

4 - 1



ESSENTIAL CHECKS



It is recommended that periodic inspections are made to ensure that dirt and debris have not become trapped between the guard and the radiator/oil cooler. Such dirt and debris would reduce the cooling efficiency of the radiator/oil cooler.

It is recommended that periodic inspections are made to ensure that all fixings are fully tightened.