

## DUCATI DIAVEL 2016 RADIATOR GUARD

Product Reference - 13089

### Kit Contents

- Ⓐ 1 x Radiator Guard
- Ⓑ 8 x 50mm x 10mm x 5mm

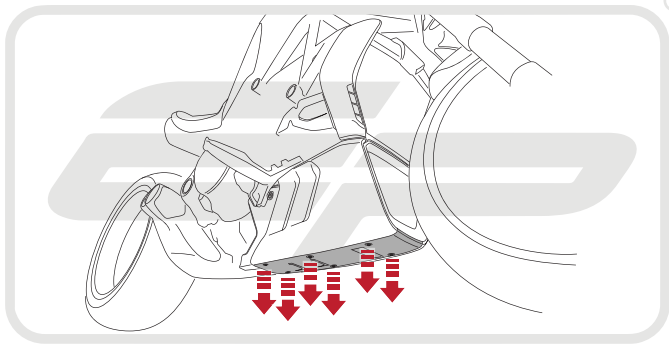

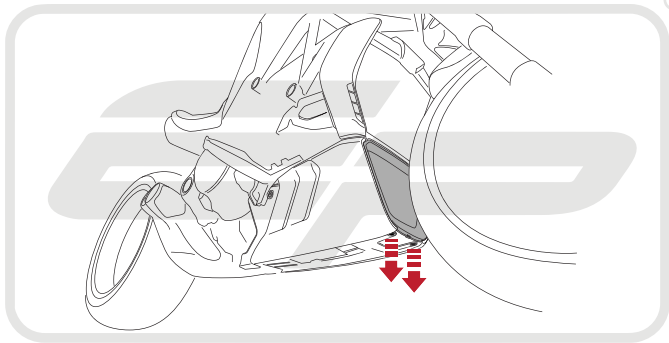

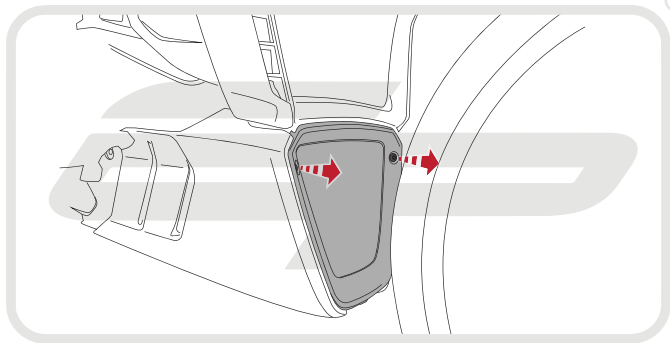

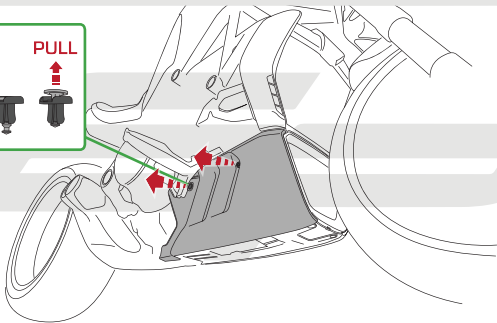
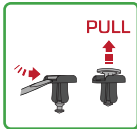

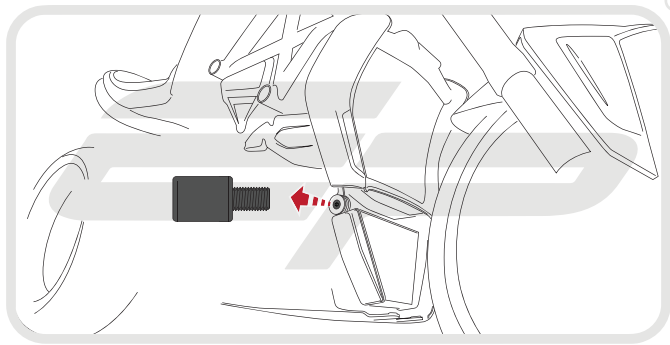

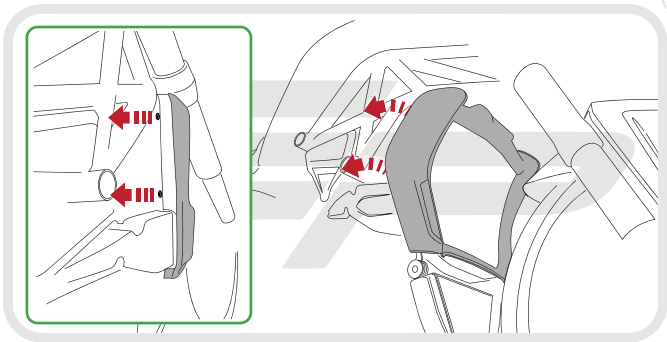

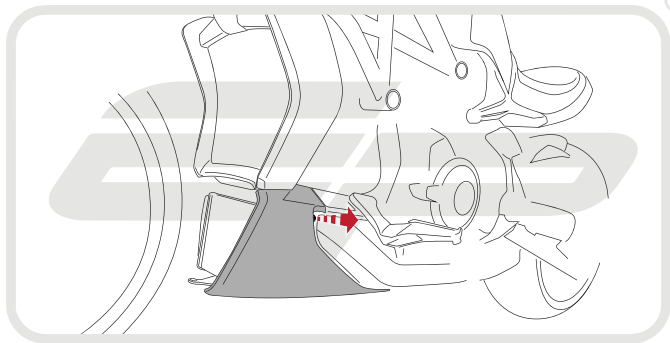



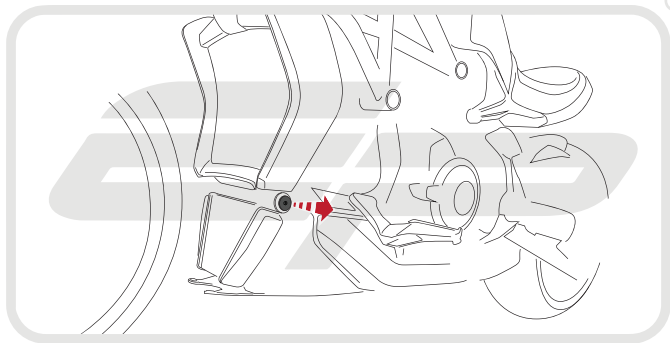

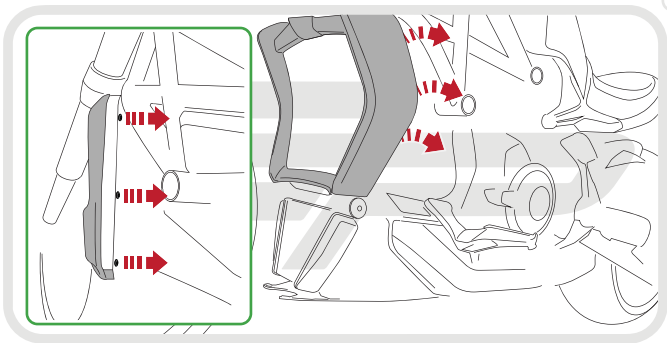

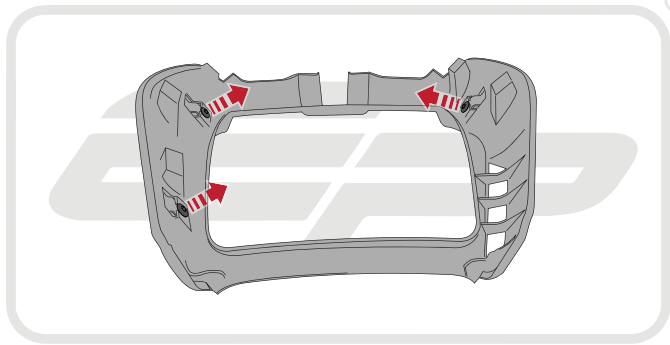

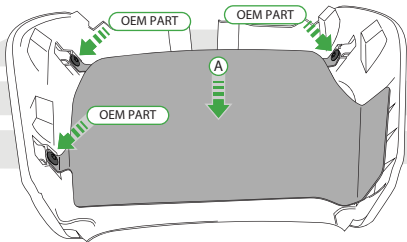

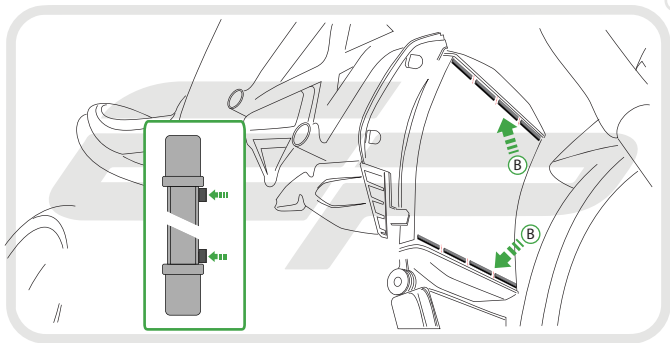



Reverse Stages

9 - 1



## ESSENTIAL CHECKS

It is recommended that periodic inspections are made to ensure that dirt and debris have not become trapped between the guard and the radiator/oil cooler. Such dirt and debris would reduce the cooling efficiency of the radiator/oil cooler.

It is recommended that periodic inspections are made to ensure that all fixings are fully tightend.