



DUCATI SCRAMBLER 2015 RECTIFIER GUARD

Product Reference - 12254

Kit Contents

- Ⓐ 1 x Rectifier Guard
- Ⓑ 2 x Mounting Spacers
- Ⓒ 2 x M6 - 45 Button Head Screws

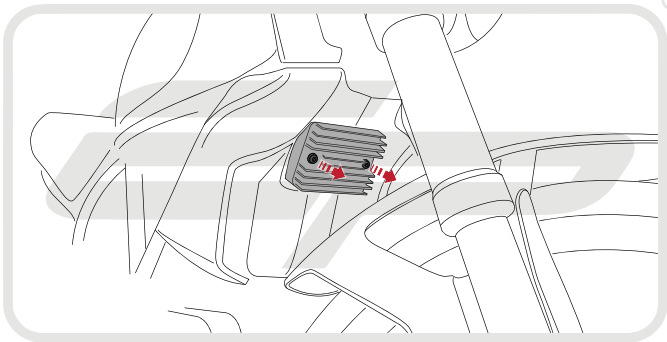

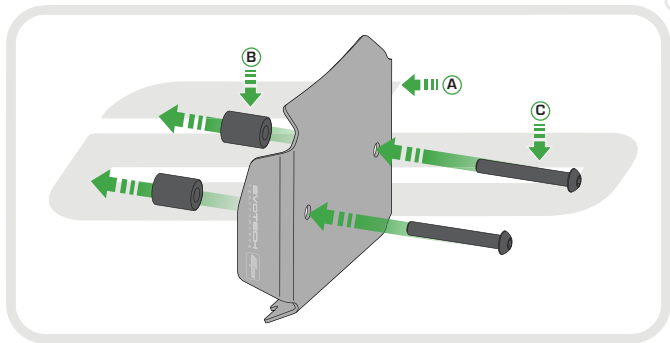

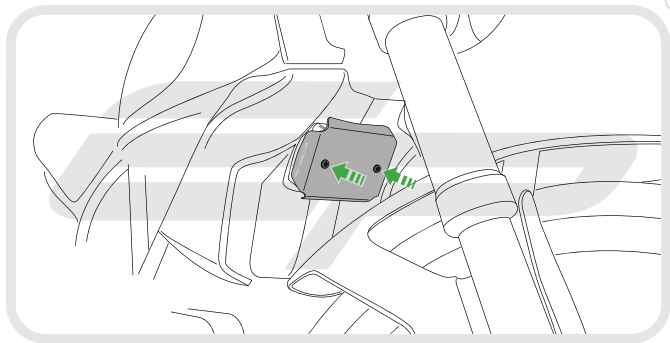



ESSENTIAL CHECKS



It is recommended that periodic inspections are made to ensure that dirt and debris have not become trapped between the guard and the rectifier. Such dirt and debris would reduce the efficiency of the rectifier.

It is recommended that periodic inspections are made to ensure that all fixings are fully tightend.